



BRUNO®

INDEPENDENT LIVING AIDS

ISO 9001 CERTIFIED



SRE-2700 ELECTRA-RIDE™ LT STAIRWAY ELEVATOR

1780 EXECUTIVE DR., P.O., BOX 84, OCONOMOWOC, WI 53066 USA
TEL.: (262) 567-4990 FAX: (262) 953-5501

Bruno invites your calls at:

1-800-882-8183

Toll free number valid throughout the U.S. and Canada

Technical Service email: service@bruno.com

Technical Service fax: 262-953-5503

www.bruno.com

DEALER:

INSTALLATION MANUAL

MAN-2700

REVISED 06-11-2004

IMPORTANT NOTES

NOTE

This stairway elevator is intended
for indoor use only
in a heated, enclosed location
above 35° F (2° C).

The warranty for the Electra-Ride™ LT
Stairway Elevator is
rendered null and void
if the unit is installed by
anyone other than an authorized Bruno dealer.

TABLE OF CONTENTS

IMPORTANT NOTES	2
INTRODUCTION	4
TECHNICAL SPECIFICATIONS	5
CARTON CONTENTS	6
OVERVIEW	7-8
INSTALLATION	9-30
Tools Necessary for Installation.....	9
Bumper Bracket Installation.....	10
Fitting the Rail.....	10
Application Guide.....	11-12
Cutting the Rail.....	13
Rail Joint Assembly.....	14
Positioning Foot Clamp Assemblies.....	15-17
Mounting the Carriage on the Upper Rail.....	18-19
Adjusting the Carriage Angle.....	20
Installing the Seat Assembly.....	20-22
Installing the Final Limit Ramp and Switch.....	22
Connecting the Power Source.....	23-24
Testing the Unit.....	25
Infrared Call/Send Transmitter.....	26
Mounting the Standard Call/Send Transmitter.....	27
Learning the Standard Call/Send Transmitter.....	28-29
When the Installation is Complete.....	29
Lubrication.....	30
ELECTRICAL	31-34
Converting Rail/Carriage for Right-Hand Operation.....	31
Converting Rocker Switch to Left Armrest.....	32
Circuit Breaker.....	33
Wiring Schematic.....	34
LONG-TERM STORAGE	35
TROUBLESHOOTING	36-37
YEARLY MAINTENANCE OPERATIONS	38
EXPLODED VIEW AND BILL OF MATERIALS	39-56
LIMITED WARRANTY	57

INTRODUCTION

Thank you for purchasing an **SRE-2700 Electra-Ride™ LT** Stairway Elevator. Be sure to check carton contents for shipping damage as soon as they are received.

Also, check the carton contents against the packing list **before** leaving the shop to install product on site.

Report any discrepancies to Bruno Independent Living Aids immediately.

Bruno encourages you to read through the installation manual before installing the Stairway Elevator. Doing so will help you install the elevator more quickly and avoid the frustration of getting to the job site only to discover that you are missing a critical tool or piece of equipment.

**NOTE:
MATERIAL DATA SAFETY SHEET(S) ON
MATERIALS USED ON THIS UNIT CAN BE
REQUESTED THROUGH OUR TECHNICAL SERVICE
DEPARTMENT**

Technical Specifications

Weight Capacity	275 lbs. (125 kg)
Speed	18 - 23 fpm (5.5-7.0 m/mn)
Power Source	two (2) 12-volt sealed, maintenance-free batteries with 24-volt continuous-duty charger
Motor	24 VDC, 2-pole, 1.32 hp
Drive	self-locking gearbox, rack-and-pinion drive
Control	constant pressure (armrest and 2 transmitters)
Brake	self-locking worm gear
Maximum incline	45 degrees
Rail	steel channel with integral drive gear rack
Seat Swivel	0, 45 and 90 degrees at top and bottom
Power Supply	100-240 VAC, 50/60 Hz, 0.85 amp power supply input, 33 VDC 1-amp transformer output, 29.6 to 27.6 VDC charging at 850 mA max., continuous monitoring.

CARTON CONTENTS

The **ELECTRA-RIDE™ LT** is shipped in 4 cartons. Check the contents of the cartons to be sure you have all of the components before beginning an installation.

**CHECK CARTON
CONTENTS FOR
SHIPPING DAMAGE
IMMEDIATELY UPON
RECEIPT**

Check the carton contents for shipping damage upon receipt. Damage claims must be filed by the **dealer**, not the manufacturer. Bruno Independent Living Aids, Inc.® cannot be responsible for shipping damage.

CARTON 1

- (1) complete carriage assembly including footrest

CARTON 2

- (1) complete seat assembly
- (2) IR transmitters

Box A

- (1) tube white lithium grease per rail set
- (1) final limit switch ramp assembly
- (1) *SRE-K-1553 bumper assembly parts kit*
- (2) bumper assemblies
- (2) pieces of Velcro®
- (10) 11" lg wire ties
- (1) *SRE-K-2705 electrical parts kit (16' rail)*
(or SRE-K-2706 for 20' rail)
- (1) custom-length charge harness
- (2) transmitter mounting brackets
- (2) *SRE-K-2701 transmitter mounting hardware kit*
- (1) power supply
- (1) *SRE-K-1518 power supply hardware kit*

Box B

- (9) foot clamp sets (**16' RAIL**) • 11 (**20' RAIL**)
 - TBD** (**CUSTOM RAIL**)
 - **DEPENDS UPON RAIL LENGTH
- (36) sheet metal screws (M 6.3 X 50 mm)(16' rail);
QTY.44 for (20' rail)
- () UPON REQUEST clamps, adjustable, 9 lbs. ea.

CARTON 3

- (1) rail half (upper)

CARTON 4

- (1) rail half (lower)
- (1) joint plate
- (1) *SRE-K-1502 joint plate hardware kit*

CARTON 5 (OPTIONAL)

- (1) rail half (lower)
- (1) joint plate
- (1) *SRE-K-1502 joint plate hardware kit*

***MSDS (Material Safety
Data Sheet) available
from Bruno upon
request. Contact
Service
Department.**

*****NOTE:
Rail sections must have
matching numbers
stamped on the
sections.**

OVERVIEW

Installation of the **ELECTRA-RIDE™ LT Stairway Elevator** consists of the following:

- * Determine whether the elevator should be a left- or right-side installation. "Left" or "right" installation is determined by the side of the stairway on which the rail is installed (viewed from the bottom of the stairs). **THE GEAR RACK WILL BE TOWARD THE CENTER OF THE STAIRS.** Unless specified otherwise, Bruno Stairway Elevators are set up for left-side installation when shipped, but can easily be converted to right-side installation. Instructions for converting the unit for right-hand installation are included later in this manual.
- * Identify and locate lower rail section and bumper bracket assembly.
- * Assemble and tighten the rail joint. **CAUTION: RAILS CANNOT BE MIXED. CHECK ID NUMBERS STAMPED AT ENDS OF RAILS.**
- * Determine the correct length for the rail (using Steps 2 & 4 from the APPLICATION GUIDE), and cut the rail.
- * Install lower bumper assembly.
- * Position rail on left or right side of stairway using rail clamp assemblies.
- * Mount the carriage on the upper rail.
- * Adjust the carriage angle by loosening the (2) *Angle Adjustment Bolts*.
- * Install seat assembly and make electrical connections.
- * When installing a **right-side ELECTRA-RIDE™ LT**, follow instructions for **Changing to Right-Hand Operation**
- * Perform a 5-6 trial runs of the **ELECTRA-RIDE™ LT** to determine final location of the rail.

OVERVIEW

OVERVIEW (CON'T.)

- * Determine the appropriate location for the remaining mounting clamps and brackets for attaching the rail to the stairs then loosely assemble the clamps and brackets to the Stairway Elevator rail.
- * Adjust and tighten the rail clamps and mounting brackets.
- * Anchor the mounting brackets to the stairs.
- * Locate and drill holes for the top bumper bracket.
- * Install the top bumper bracket.
- * Determine where the power supply will be positioned, and install rail wire lead accordingly.
- * Position power supply at upper or lower landing.
- * Route wire to household outlet.
- * Mount remote call/send transmitters.
- * Test unit for proper operation.
- * Train customer in safe and convenient operation of the Stairway Elevator.

REMEMBER:

No installation is complete until the customer has been trained to use the Elevator smoothly and safely. After demonstrating correct operation, have the customer operate the Elevator several times while you are available to answer questions. **BE SURE THE CUSTOMER UNDERSTANDS ALL SAFETY ASPECTS OF USING THE ELEVATOR.** Patience and thoroughness in this phase of the installation are often rewarded with repeat business and customer referrals.

Tools Necessary for Installation

- Protractor level, builder's level
- Socket set, metric (10 mm through 22 mm)
- Ratchet, with 6" extension
- Combination wrench set, metric (10 mm through 22 mm)
- Phillips screwdrivers
- 5/16" socket (clamp screws)
- 9/16" and 5/8" open-end wrench (limit switch adjustment)
- 5/16" open-end wrench
- Electric drill with letter 'O' (.316") and 1/4" bit
- Hacksaw with 2 or 3 blades, or metal cutting bandsaw
- 20' tape measure
- Small dead blow hammer
- Rubber mallet
- C-clamp
- Wire crimper and stripper
- Flashlight
- Needle nose pliers
- Scissors or knife
- Extension cord
- Double-sided foam tape
- File
- 12" adjustable wrench
- 90-degree needle-nose pliers

NOTE:

The standard stairway elevator is suitable for stairway angles up to 45 degrees.

TIPS FOR A FASTER, SMOOTHER INSTALLATION:

- **Be sure you have all necessary parts and tools before traveling to installation site.**
- **Loosely assemble the foot clamp assemblies before traveling to the installation site.**

INSTALLATION

ASSEMBLY

- 1) Determine whether a left- or right-side installation is appropriate for the site. "Left" or "right" refers to the side of the stairway on which the rail is installed (as viewed from the bottom of the stairs). *Unless otherwise specified Bruno Stairway Elevators are shipped from the factory in the left-side configuration.* Conversion to right-side installation is easy (instructions included later in this manual).
- 2) Identify and locate lower rail section appropriate to the installation (left or right).

BUMPER BRACKET INSTALLATION

- 1) Assemble lower rail.
- 2) Install lower bumper bracket.

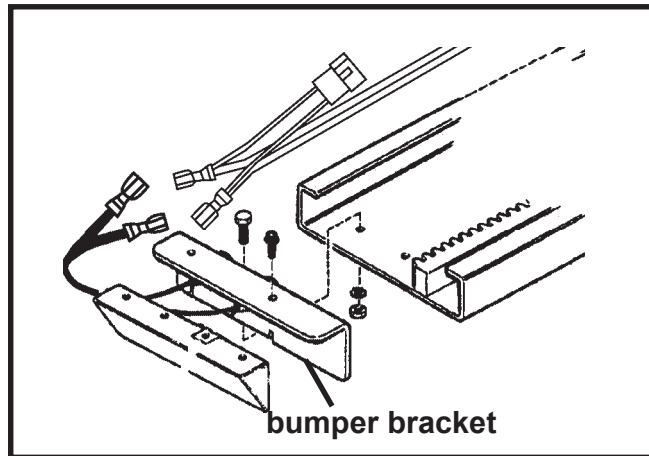

FITTING THE RAIL

- 1) Determine the correct length for the rail by measuring along a straight line placed on the stairs. (SEE STEP 2 IN THE APPLICATION GUIDE) To that amount, add Measurement B (STEP 4 IN THE APPLICATION GUIDE). This process will allow you to custom fit the Elevator to your customer by determining the most comfortable seat-to-floor height within the space available at the top of the stairs.

NOTE: The rail must rest approximately 2" above the step nosing, and extend from the lower floor to a point beyond the nosing of the top step (see Step No. 4 of the Application Guide). In some cases where the bottom landing is made of material such as concrete, ceramic tile or slate, the last bracket on the landing may be omitted. In this case, a bracket must be added on the second-to-last step (bottom), and at the top of the stairway.

REMINDER:

THIS RAIL MUST BE INSTALLED APPROXIMATELY 2" ABOVE STAIR NOSING. OTHERWISE, FOOTREST WILL HIT THE STEPS, CAUSING INTERMITTENT OPERATION.

APPLICATION GUIDE FOR BRUNO STRAIGHT STAIRWAY ELEVATOR SYSTEMS

DEALER: _____

PO# _____

CUSTOMER: _____

DATE: _____

STEP 1 DETERMINE THE STAIRCASE ANGLE

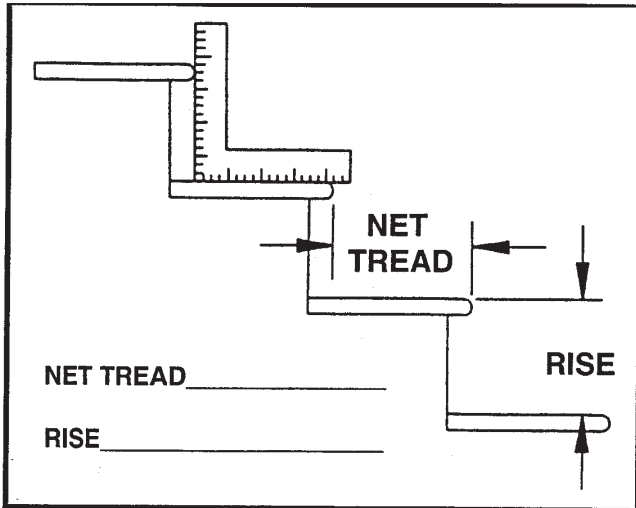

RISE	NET TREAD						
	12"	11"	10"	9"	8"	7"	6"
6"	27	29	31	34	37	41	45
7"	30	33	35	38	41	45	
8"	34	36	39	42	45		
9"	37	39	42	45			
10"	40	42	45				
11"	43	45					
12"	45						

NOTE: ANGLES ABOVE ARE ROUNDED TO THE NEXT DEGREE. FOR ANGLES ABOVE 45 DEGREES, CONSULT BRUNO FOR SPECIAL ORDER DETAILS.

STEP 2 DEFINE STAIRWAY DIMENSIONS AND DETAILS

STAIR TREAD MATERIAL _____

STAIRCASE WIDTH _____
(32" Min. for Standard Unit)

LOWER LANDING MATERIAL _____

OBSTRUCTIONS _____
(i.e. Handrails, Moldings)

UPPER LANDING MATERIAL _____

STEP 3 CHAIR AND RAIL DETAILS

SIDE OF STAIRWAY THE RAIL IS TO BE MOUNTED, LOOKING UP FROM BOTTOM:

LEFT: RIGHT:

CHAIR UPHOLSTERY:

TAN VINYL: TAN FABRIC:

RESIDENTIAL KEY PACKAGE:

COMMERCIAL PACKAGE:

PLEASE REFER TO "STEP 3" ON THE FOLLOWING PAGE FOR DETAILS.

STEP 4 RAIL LENGTH

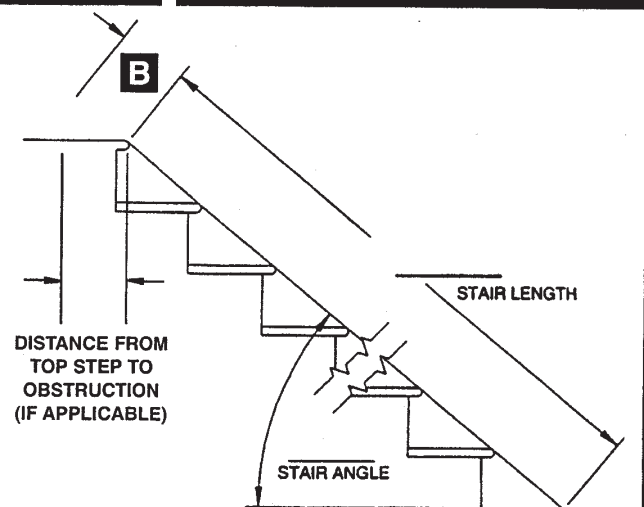

DETERMINE THE STAIR LENGTH: _____

ADD "B" TOP RAIL EXTENSION: _____

PLEASE REFER TO "STEP 4" ON THE FOLLOWING PAGE FOR DETAILS.

Overall Rail Length Required: _____

16' STOCK _____ 20' STOCK _____

24' STOCK _____ CUSTOM CUT RAIL _____



Bruno Independent Living Aids, Inc.
1780 Executive Drive, P.O. Box 84,
Oconomowoc, WI 53066

1-800-882-8183 • (262) 567-4990

www.bruno.com

SALES DEPT. FAX (262) 953-5501

FORM ESLG D 0996-4 2/01-2 © Bruno Independent Living Aids, Inc. 2001

INSTALLATION

STEP 3

SRE-2700 ELECTRA-RIDE™ LT APPLICATION DETAILS

TOP VIEW

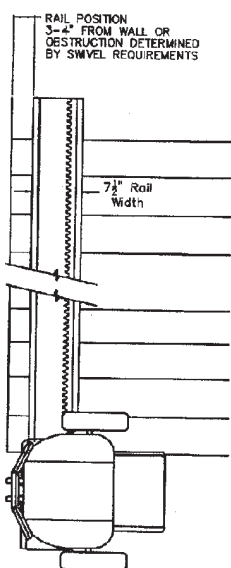

FRONT VIEWS

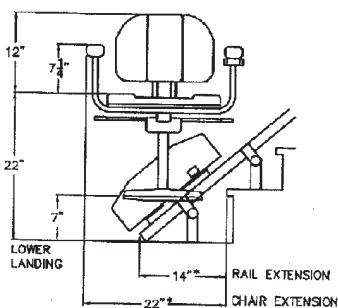
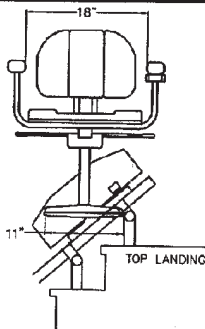

* LOWER LANDING EXTENSION DIMENSIONS ARE BASED ON 40 DEGREE RAIL SLOPE AND 8" 1ST RISER HEIGHT. DIMENSIONS WILL VARY BASED ON SLOPE AND RISER HEIGHT.

SIDE VIEWS

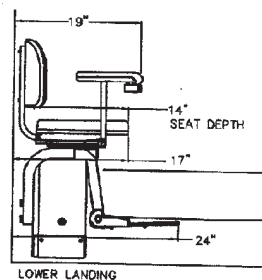
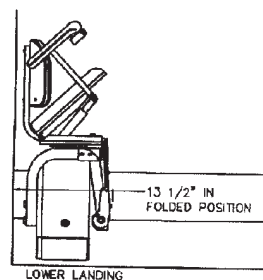

UPPER LEVEL ENTRY/EXIT SEAT HEIGHT IN INCHES

	17"	18"	19"	20"	21"	22"	23"	
35°	6.2	7.3	8.5	9.6	11.1	12.0	13.1	A
	7.5	8.9	10.3	11.7	13.2	14.6	16.0	B
36°	6.0	6.9	8.3	9.5	10.6	11.9	13.0	A
	7.4	8.8	10.2	11.7	13.1	14.6	16.0	B
37°	5.8	7.0	8.2	9.3	10.5	11.7	12.8	A
	7.2	8.7	10.2	11.6	13.1	14.6	16.0	B
38°	5.7	6.8	8.0	9.2	10.4	11.6	12.7	A
	7.1	8.6	10.1	11.6	13.1	14.6	16.0	B
39°	5.4	6.7	7.8	9.0	10.2	11.4	12.6	A
	6.9	8.5	10.0	11.6	13.0	14.6	15.9	B
40°	5.3	6.4	7.7	8.8	10.0	11.3	12.4	A
	6.8	8.3	9.9	11.6	13.0	14.6	15.9	B
41°	5.1	6.3	7.5	8.7	9.9	11.1	12.3	A
	6.7	8.3	9.9	11.5	13.0	14.6	15.9	B
42°	5.0	6.2	7.4	8.6	9.9	11.1	12.3	A
	6.6	8.2	9.8	11.4	13.0	14.5	15.9	B
43°	4.7	5.9	7.1	8.4	9.5	10.8	12.0	A
	6.4	8.1	9.7	11.4	13.0	14.5	15.9	B
44°	4.5	5.7	6.9	8.2	9.4	10.6	11.8	A
	6.2	7.9	9.6	11.3	13.0	14.5	15.9	B
45°	4.3	5.5	6.8	8.0	9.2	10.5	11.7	A
	6.0	7.8	9.5	11.3	13.0	14.5	15.9	B

STEP 4

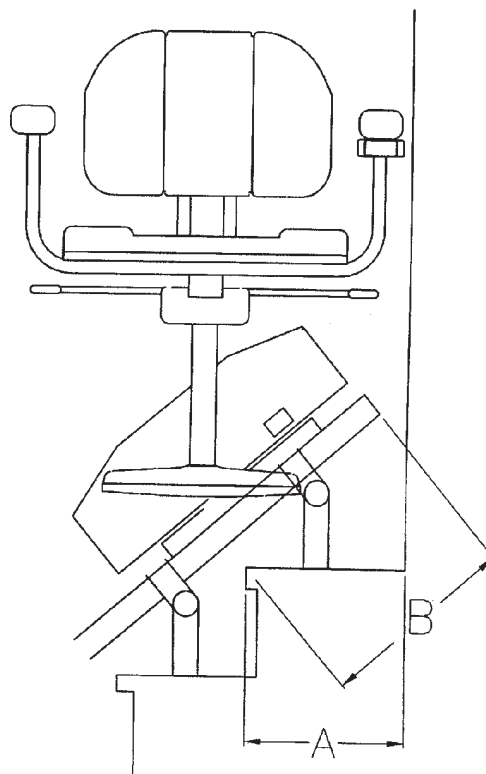

IF A is < 3 or B is > 12, then one or more adjustable clamp sets (SRE-00361) are required.

CUTTING THE RAIL

IMPORTANT NOTE!

Under no circumstances should a rail section be cut shorter than 18" (46 cm).

There must be at least (2) clamps on a short rail section (1 at the rail joint and 1 at the rail end). Cutting a rail shorter than 18" (46 cm) would not allow enough room for the (2) necessary clamps.

Example:

After measuring the staircase, you determine you need 9 feet of rail. With your (2) 8-foot sections you decide to use (1) 8-foot section and cut the remaining (1) foot from the second 8-foot section. Doing this could yield a rail piece with insufficient weld.

Instead, Bruno recommends cutting at least one foot off one of the 8-foot sections (leaving 7 feet of rail) and then cutting 2 feet from the second 8-foot section. You will have a (1) 7-foot section and (1) 2-foot section, both of which are long enough to be properly mounted (2 clamps minimum per short rail).

NEVER CUT OFF THE JOINT END!

The M6 bolts securing the gear rack *must* remain intact.

Cut off the end with the pre-drilled charge contact mounting holes.

Then, using the provided template, redrill (2) holes on each end of the rail.

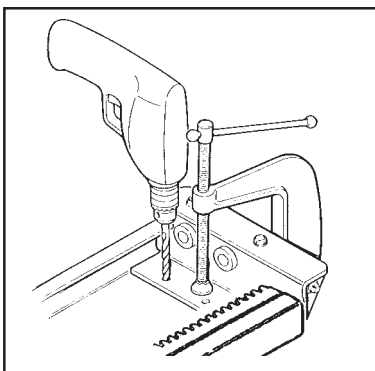

use "O" size drill bit
(8.03mm/.316")

- 1) Use a metal-cutting power saw or manual hacksaw to cut the rail to length. Cut off the end of the rail to be located at the top of the stairway.
- 2) Use a file or other appropriate tool to deburr the cut end of the rail. Soften any sharp edges which might abrade the insulation of the wiring to be routed to the bumper at the end of the rail.
- 3) Use a C-clamp to hold the upper bumper bracket in place at the cut end of the rail. Use the holes in the bumper bracket as guides to drill mounting holes in the rail using an "O" size (8.03 mm/.316") drill bit.

INSTALLATION

RAIL JOINT ASSEMBLY

NOTE:
The rail is always installed with the gear rack towards the center of the stairs and gear teeth facing the wall.

- 1) Assemble the rail joint by attaching the bottom plate to the rail with the screws, lock washers and hex nuts provided with the unit. Install the bolts, internal-tooth washers and hex nuts through the joint blocks on both sides of the rail. Tighten all bolts securely and make sure screw heads are flush with the surface of the inside of the rail. **PLEASE REFER TO EXPLODED VIEWS AT BACK OF MANUAL.**

INSTALLATION SUGGESTION

Once two sections of rail are installed, and before installing the carriage, run a plumb line along the rail. If the rail bows, insert shims or readjust clamps.

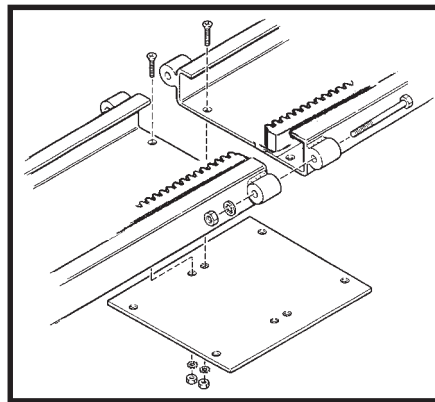

NOTE:
The chamfered edges of the holes must face "up" toward the bottom of the rail.

POSITIONING FOOT CLAMP ASSEMBLIES

clamp placement order

- *bottom landing*
- *first tread up from bottom landing*
- *top landing*
- *first tread down from top landing*
- *closest tread above and below the rail joint(s)*
- *minimum of every third tread over remainder of staircase.*



4" as measured from back edge of rail to wall.

- 1) Place rail mounting foot clamps in the pattern as indicated.

Be sure to leave a minimum space of 4"*, as measured from the back edge of the rail to the wall.

***The 4" clearance is needed if the seat is to swivel 90 degrees. For installations where the seat will swivel less than 90 degrees, the rail-to-wall clearance may be reduced to between 3" and 3-1/2". Frequently check the seat-wall clearance during installation.**

Note: *If top or bottom clamp is omitted because the landing is cement or ceramic tile, or in the event that the owner wishes not to drill holes in the landing, a set of clamps should be added on the second-to-last step and at the top of stairway.*

INSTALLATION

INSTALLATION ON CARPET

Before securing the foot clamp assemblies with hardware, seat them using a deadblow hammer. Use a rubber mallet to compress the rug and pad before anchoring the clamp.

- 2) For ease of installation, finger tighten all clamp assemblies to rail. *The clamp assembly should be positioned so the nut is closest to the wall.*
- 3) Slide top and bottom clamps down on the rail until firmly seated on step. When installing on carpeted stairs, use a rubber mallet on the clamps to compress carpet and pad before anchoring to steps.
- 4) Drill in one screw in the **foot nearest the wall** of each of the top and bottom of foot of clamp assemblies.

This will enable the installer to change the position of the rail if necessary and minimize the number of holes drilled in the wrong location.

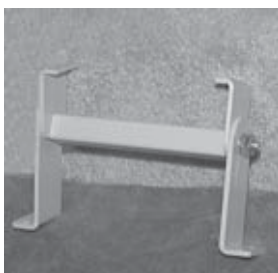
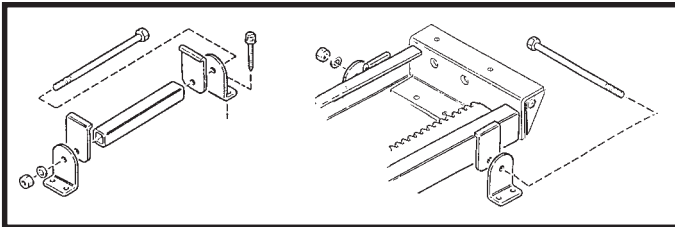

Bruno recommends installing the screws in the back clamp (the one closer to the wall) first, then the screws in the front of the clamp.

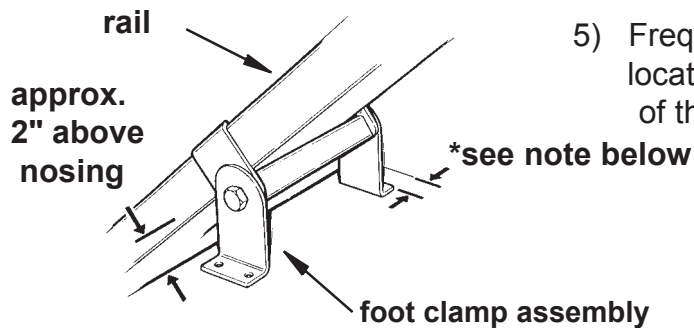

- 5) Frequently check the measurements at the key locations indicated to ensure proper positioning of the clamp assemblies.

***Install foot clamps at least 2-1/2" from wall (approx. 4" between the back edge of the rail and the wall). Provide additional foot clamp-to-wall clearance if seat needs to swivel against wall.**

INSTALLATION NOTES

For installations on hardwood stairs, Bruno recommends drilling a pilot hole before inserting fasteners.

If threaded fastener extends below a stair tread that is exposed, it can be trimmed flush with pliers.

Bruno ships the Stairway Elevator with fasteners appropriate for **wooden stair treads only**.

Other stair material may require different fasteners.

Please contact Bruno Independent Living Aids, Inc. for information.

INSTALLATION

MOUNTING CARRIAGE ON UPPER RAIL

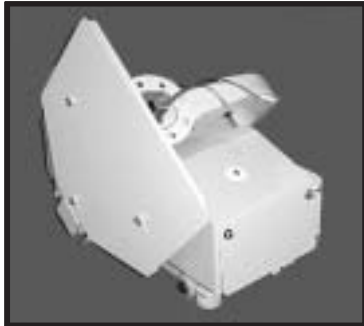

- 1) Remove the carriage from the shipping carton.



circuit breaker off

- 2) Make sure circuit breaker is OFF.



sliding carriage on rail

- 3) Manually slide the carriage onto the rail until approximately half of the carriage is on the rail.
- 4) Manually turn the motor pulley to fully engage the entire carriage onto the rail.



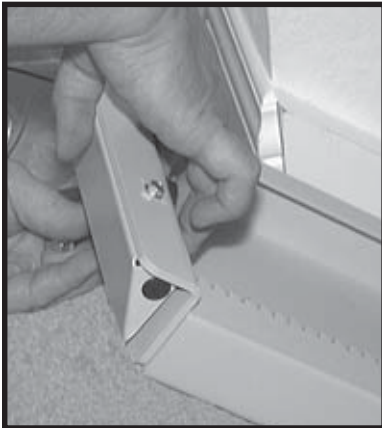

- 5) To ensure that the carriage remains in the appropriate position on the rail while completing the installation, mount the upper rail bumper. Use the M8 x 1.25 x 20 mm hex head cap screws and a 13 mm wrench.



carriage on rail

Before tightening the brackets, check to make sure that the bumper wires are not trapped under the bumper bracket at the lower landing.

INSTALLATION

ADJUSTING THE CARRIAGE ANGLE

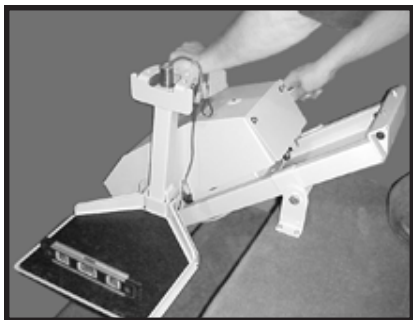

- 1) Fold down the footrest
- 2) With the footrest folded down, LOOSEN BUT DO NOT REMOVE the (2) M14 x 2 x 70mm hex head cap screws using a 22 mm wrench.

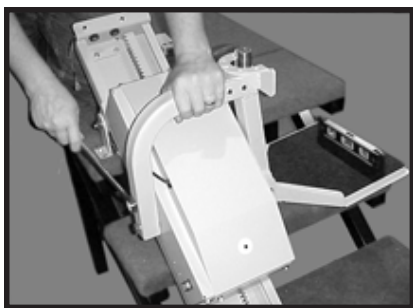

- 3) Place a level on the footrest.
- 4) Pivot the seat support tube forward or backward as necessary to level the footrest.
- 5) While holding the seat support tube steady, tighten the (2) screws loosened in Step 9 to a torque of 80 ft. lbs.

REMINDER:

Recheck with level after tightening adjustment bolts.

INSTALLING THE SEAT ASSEMBLY

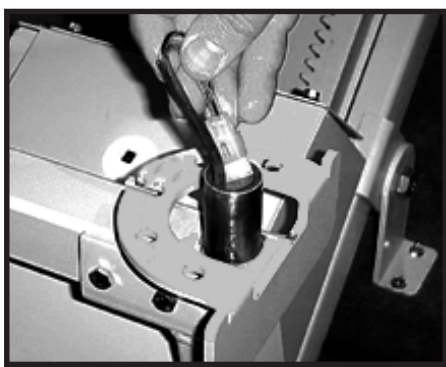

- 1) Make sure the rocker switch and seat safety switch wires are tucked into the seat swivel tube.



- 2) Clip the shipping tie securing the swivel cover assembly.

INSTALLATION

INSTALLING THE SEAT ASSEMBLY (con't.)



- 3) Using a Phillips head screwdriver, remove the (2) cylinder bumpers and (4) screws securing the swivel cover.



- 4) Put the swivel cover to the side.

MAKE SURE FOOTREST IS DOWN!



- 5) With the SEAT FOLDED UP and while LIFTING UP THE SWIVEL LEVER, slide seat post over the wires and onto the seat support tube.
- 6) To make sure the seat assembly is completely seated on the support tube, rotate the seat assembly back and forth while gently pushing the seat post down onto the tube.

- footrest down
- seat cushion folded up
- lift up swivel lever
- slide seat post over wires and tube

INSTALLATION

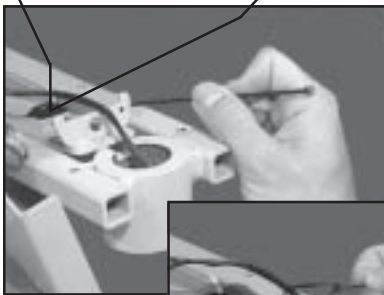

INSTALLING THE SEAT ASSEMBLY (con't.)

- 7) Connect the rocker switch lead first.
- 8) Pick up the swivel cover.
- 9) Plug in the seat safety switch.
- 10) Insert (1) wire tie through the hole in the swivel stop as shown.
- 11) Tighten this wire tie around the wire harness (see illustration to left).
- 12) Insert a second wire tie through the anchor as shown.
- 13) Tighten this second wire tie around the wire harness.
- 14) Trim the wire ties.
- 15) Tuck the wires to route them away from the spring and seat safety switch to avoid pinching.
- 16) Make sure the spring sits in the opening of the swivel switch actuator.
- 17) Remount the swivel cover.
- 18) Using a Phillips head screwdriver, insert and tighten the (2) cylinder bumpers and (4) screws securing the swivel cover.



ramp just touches the roller

carriage against upper bumper

INSTALLING THE FINAL LIMIT RAMP AND SWITCH

- 1) Make sure the carriage is positioned against the upper bumper.
- 2) Position the final limit ramp so that the down side of the ramp just touches the roller of the final limit switch.
- 3) Using a 10 mm wrench, tighten the (2) M6 screws as shown in the photo to the left.

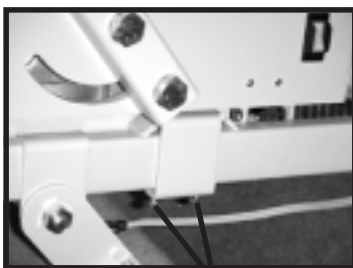

M6 screws

CONNECTING THE POWER SOURCE



circuit breaker

- 1) Check that:
 - the circuit breaker is OFF.
 - all foot clamps are in the correct position;
 - the rail is straight (use a plumb line as a guide).
- 2) Determine the location of the wall outlet for the power supply.
- 3) Position the power supply in a suitable permanent location near either the top or bottom end of the rail, depending on the location of the wall outlet.
- 4) Place the pigtail harness end of the power cable near the power supply.
- 5) Route the power cable to the end of the rail opposite the power supply by threading it under the rail and behind the foot clamps.

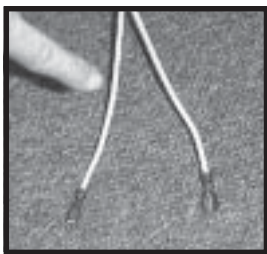

ribbed to red (+) (female) smooth to black (-) (male)

- 6) Notice that the end of the cable OPPOSITE THE PIGTAIL HARNESS has been split slightly, and includes one male and one female connector. The sheathing of one lead is ribbed (in photo to left, finger points to ribbed sheath). The other lead's sheathing is smooth.
- 7) Now that the power cable has been routed to the end of the rail opposite the power supply (Step 5), take that length PLUS approx. 8". Then:
 - increase the split
 - cut off the excess lead
 - remove and discard the existing connectors
 - strip the freshly cut wire ends.
 - install the new connectors (provided)



- 8) Connect the power source leads to the bumper charge contact leads as shown.
- 9) Secure the power lead to the rear clamps (ones closest to the wall) using the wire ties provided.

Be sure that this wiring is mounted securely to avoid damage.

INSTALLATION

CONNECTING THE POWER SOURCE (con't.)

10) Turn the circuit breaker ON.



power supply



11) Plug power supply into a grounded 120VAC wall outlet.

12) Secure the power supply with the bracket provided.

Be sure the power supply will not pose a tripping hazard.

13) Mount (1) remote at the top of the rail and (1) at the bottom of the rail. (Refer to the Standard Call/Send Transmitter section later in this manual.)

The power supply should be plugged into a household outlet at all times.

THE ONLY EXCEPTION IS WHEN TURNING UNIT 'OFF' (SEE LONG TERM STORAGE SECTION).

If the power supply plug and wire will be located in an area where the power supply could be accidentally unplugged, Bruno recommends the use of a plug lock (available at hardware and home improvement stores).

TESTING THE UNIT

INSTALLATION NOTES

Direction of travel of the seat/carriage corresponds to the side of the rocker switch depressed.

A slight delay will occur between the time the rocker switch is depressed and the initiation of carriage movement. This is normal and is a function of the *soft start* feature of the controller.

The unit should travel noticeably faster going up than down.

- 1) Before securing, all clamps and with the seat in the central riding position, use the rocker switch to run carriage/seat assembly completely down and up the rail. Observe the seat-to-wall clearance.

A clearance of 1/2" to 1" is acceptable.

- 2) Repeat the run with the seat in the folded position. If necessary, adjust the rail placement by sliding it closer to, or further from the wall.
- 3) Make a total of 5 or 6 trial runs to be sure all components are functioning correctly, and that proper seat-to-wall clearance is maintained over the entire length of travel.

These 5-6 runs will also help clean paint chips out of the gear rack which can be vacuumed or brushed away (see Lubrication section).

- 4) Once the rail position is determined, place one screw in the back foot of each clamp assembly to hold the rail in place while securing the foot clamp assemblies. Placing this one screw will also help prevent the clamp foot from rotating while tightening the screws.
- 5) Tighten the bolts securing the foot clamp assemblies to the rail.
- 6) Install and tighten the screws in the remaining foot clamps (back clamp first, then front clamp).
- 7) Check tightness of all screws/bolts.
- 8) Run the carriage/seat assembly up and down the rail to recheck the seat-to-wall clearance, and to verify correct operation of all elevator components.

ALWAYS PARK THE CARRIAGE AT THE UPPER OR LOWER END OF THE RAIL TO KEEP BATTERIES FULLY CHARGED.

INSTALLATION

INFRARED CALL/SEND TRANSMITTER

The call/send system on the Bruno SRE-2700 is based on infrared (IR) controls, the same type of control used for televisions and stereos.

Like a television remote, the SRE-2700 hand-held transmitter may experience certain types of interference. Receivers are mounted on both sides of the SRE-2700 carriage to minimize interference.

Should interference occur, the unit will stop. This feature has been integrated into the SRE-2700 to ensure your safety.

The direct line between the transmitter to either of the (2) transmitters should be clear of obstacles for optimal operation.

To reduce the possibility of interference:

- while riding in the seat, ALWAYS operate the Elevator using the rocker switch on the armrest.

Operating the SRE-2700 with a transmitter while riding in the seat can lead to signal interference.

- DO NOT mount the transmitters behind an obstacle such as a rail post.
- DO NOT allow direct sunlight to shine on the receivers (blinding the receivers on the carriage).
- DO replace transmitter batteries regularly.

Depleted or nearly-depleted batteries alter the effective range of the transmitter.

- DO keep the transmitter and receiver lens free of dirt and debris.

Use a non-abrasive cleaner suitable for glass or acrylic surfaces. Do not use polishes or cleaning products containing wax. These products will leave a film on the lens that will reduce the signal transmission range.

INSTALLATION

STANDARD CALL/SEND TRANSMITTER



The 9V battery is inserted backwards in the IR transmitter when shipped from the Bruno factory. Prior to operating the SRE-2700, the installer must remove the battery and reinsert it so that the (+) and (-) poles are properly connected.

MOUNTING THE CALL/SEND TRANSMITTERS TO THE WALL

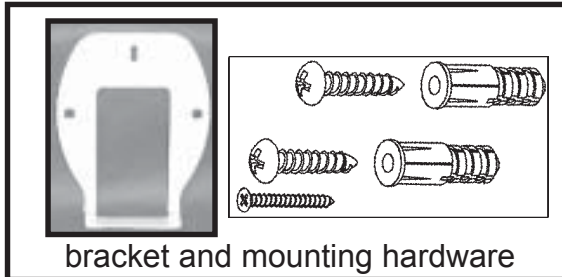

Remember to mount the transmitters in locations which are out of the reach of children, yet always visible to the operator from the stairway elevator.



Step 1

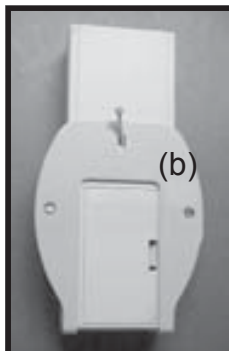

Steps
2 & 3



Step 4

- 1) On the back of the transmitter, loosen and remove the screw (a) securing the two halves of the transmitter.
- 2) Place the bracket (b) on the back of the transmitter. The base of the bracket will be flush with the bottom of the transmitter, with the base of the bracket pointing toward the front of the transmitter.
- 3) Insert the longest screw provided in the mounting hardware kit (see illustration above left) through the top hole in the bracket and through the corresponding hole in the back of the transmitter. Tighten, without overtightening to avoid damaging the transmitter back.
- 4) Turn the transmitter/bracket unit over so that the front of the transmitter is facing you.
- 5) Mount this unit to the wall using the two (2) #8 x .75" lg Phillips pan head sheet metal screws and the two (2) plastic ribbed anchors provided.
- 6) Run the unit up and down the stairs using the remote call/sent transmitter. Test both transmitters.
- 7) Repeat the test with the installer or installer's assistant sitting on the seat.

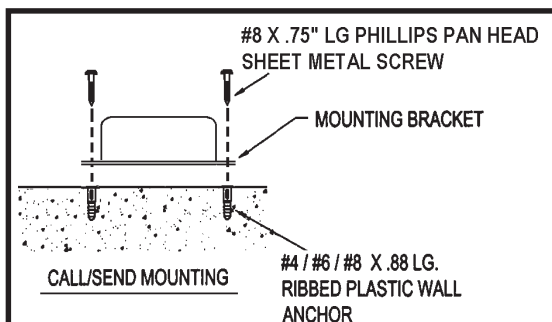

Step 5

NOTE:
INSTALLATION OF THE CALL/SEND UNIT MAY VARY BY LOCAL CODE. PLEASE REFER TO LOCAL CODES FOR INSTALLATION GUIDELINES.

INSTALLATION

LEARNING THE REMOTE INFRARED TRANSMITTER

(not necessary when installing unit for the first time)



The operating channel of the two (2) infrared transmitters included with the SRE-2700 is pre-set at the Bruno factory. Should it become necessary to re-learn the transmitters (for example, if there are multiple units in the same location, or in the event you have to replace transmitters) proceed as follows:

- 1) Turn off the circuit breaker.
- 2) On the CARRIAGE COVER, locate and remove the 3/4" black plug (center top of the carriage approximately half-way between the two white infrared receivers). Please refer to the photo to the left.
- 3) Look through the hole in the carriage cover and locate the RED BUTTON on the circuit board.
- 4) Have a flat-nose screwdriver nearby. You will use it to press the red button (through the carriage cover hole) in a later step.

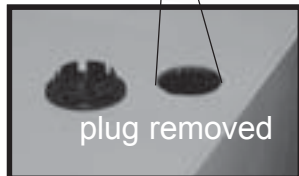
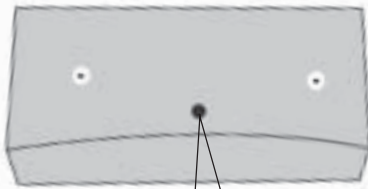

- 5) On one of the IR TRANSMITTERS, remove the screw (a) securing the back to the transmitter. [If the transmitter is mounted to a wall, unscrew the (2) mounting bracket screws, turn the transmitter over and remove screw (a) securing the mounting bracket and the transmitter back.]

- 6) Remove the transmitter back and set aside with its screw.

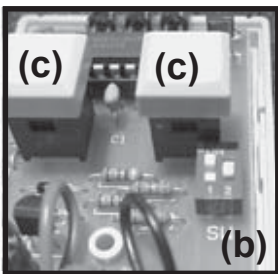

- 7) On the TRANSMITTER board, locate the blue switch (b) labelled "SW".

- 8) Change the configuration for switches 1 and 2.

Note: There are four possible configurations:

- 1 up, 2 down (default manufacturer's setting)
- 1 up, 2 up
- 1 down, 2 up
- 1 down, 2 down

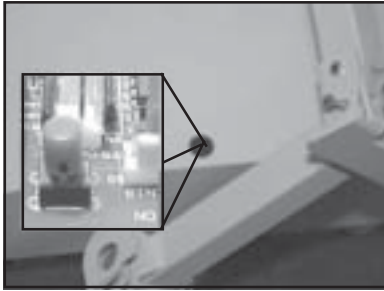

close-up of red button
as seen through plug hole

NOTE:
While using the remote call/send, you may experience some intermittent operation. This will not harm the unit. However, while using the rocker switch, operation should NOT be intermittent.

- 9) Once you have changed the switch positions:
 - Turn on the CARRIAGE circuit breaker.
 - Wait until you hear a BEEP.
 - Using a flat-nose screwdriver, reach through the hole in the CARRIAGE COVER to **press and hold** the red button on the CARRIAGE circuit board.
 - **AS YOU HOLD DOWN** the red button, press one of the pushbuttons on the TRANSMITTER.
 - Count to five.
 - Release the two buttons.
 - Depress either of the transmitter buttons.
 - If the carriage moves, the new configuration has been accepted and the transmitter relearned.
 - If the carriage does not move, repeats Steps 8 and 9.
- 10) Make sure both transmitters are set to the same switch configuration.
- 11) Remount and secure the transmitter back (remount on wall if applicable).
- 12) Remount the carriage cover.
- 13) Remount the footrest.
- 14) Reinsert the black plug into the hole in the carriage cover.

WHEN THE INSTALLATION IS COMPLETE

- Verify proper operation of the power supply, call/send transmitters, on/off switch, footrest, safety switches, and carriage limit switches.
- Inform the customer of the location of the Owner's Manual. Encourage him/her to become familiar with its contents.
- Train the customer to use the stairway elevator correctly and safely. Be sure to have him/her operate the unit while you are there to answer any questions and address any concerns.

INSTALLATION

LUBRICATION

PRIOR TO LUBRICATION

If not already done, run the carriage up and down the rail five to six (5-6) times. This will clean the paint chips out of the gear rack. Vacuum or brush the gear rack and rail to remove any paint chips loosened during this operation. Once the gear rack and rail are clean and free of paint debris, proceed with lubrication.

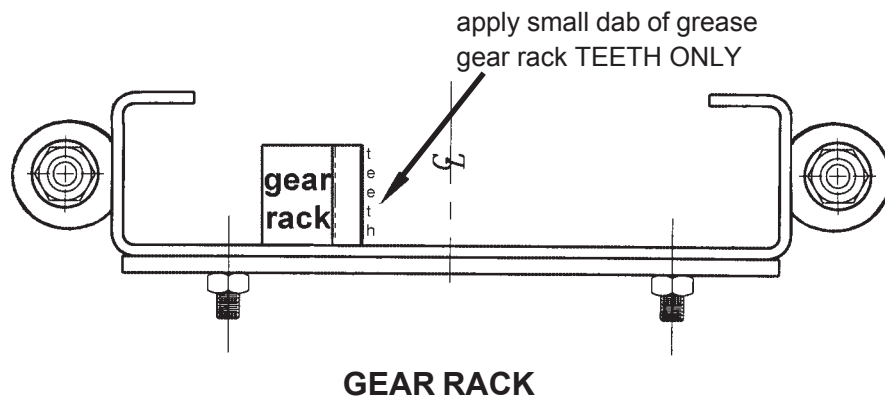

1. Apply a dab of white lithium grease to the gear rack TEETH ONLY (approx. every 6 inches).

REVERSING OPERATION (for right-hand installation)

As shipped from the factory, the Elevator is set up for left-hand installation (as viewed from the bottom of the stairs.)

In the field, however, should the dealer/installer need to convert the Elevator from left-hand to right-hand operation, follow the instructions given below.

Note that it is not necessary to change the rocker switch when converting to a right-hand installation. Only in the event that the user does not have use of his/her right hand would moving the rocker switch to the left armrest be necessary.

Instructions for changing the rocker switch from the right armrest to the left armrest immediately follow the instructions for converting the circuit board for right-hand operation.

To convert the rail/carriage for right-hand operation:

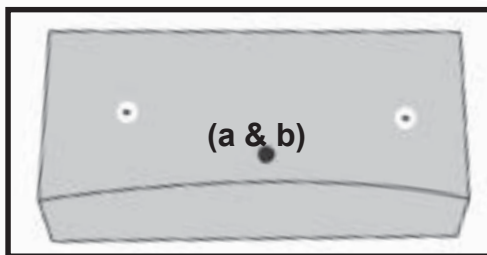

carriage: top view

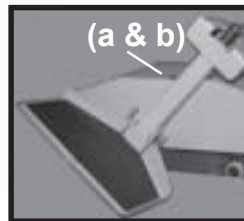

carriage and footrest: front view

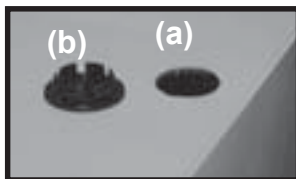

access hole (a) to circuit board with plug (b) removed

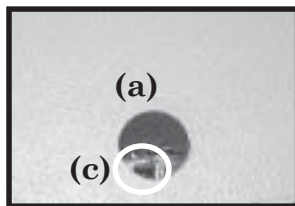

jumper (c) on circuit board as seen through hole (a)



jumper (c)

- 1) Remove the 3/4" black plug (b) located in the center top of the carriage (approx. half-way between the two white infrared receivers).
- 2) Look through the hole now exposed in the carriage. Visually locate the jumper (c) on the circuit board.
- 3) Carefully grasp the jumper (c) with a pair of needle-nose pliers.
- 4) Pull up on the jumper (c) with the pliers to disengage the jumper from the pins on the circuit board.
- 5) Remove the jumper (c) from the carriage.

Three pins are now exposed on the circuit board.

- 6) Insert the plug (b) into the hole (a) in the top of the carriage.
- 7) Place the jumper in the bag with the technical manual and give to the owner of the SRE-2700 for future use should s/he wish to convert the unit back to left-hand operation.
- 8) Removal of the jumper automatically converts the circuit board of the SRE-2700 to right-hand operation.

ELECTRICAL

To convert the rocker switch to the left armrest:

- 1) Remove the (4) Phillips flat head machine screws securing the seat cushion.
- 2) Pull out the black, split grommet (a) located under the rocker switch.
- 3) Carefully remove the rocker switch (b) from its housing (c):
 - Gently pry under the switch gasket, all the way around the switch.
 - Once the switch is free from the housing, carefully pull it out of the housing.
- 4) Disconnect the rocker switch wire harness.
NOTE WIRE COLOR LOCATIONS AND SWITCH ORIENTATION
- 5) Unscrew the screw (d) securing the rocker switch housing to the armrest tube.
- 6) Remove the black grommet from the back of the rocker switch housing.
- 7) Place the wire harness connectors one behind the other (in line). Use masking tape to hold in this position.
- 8) Pull the taped end of the wire harness through the back of the housing.
- 9) Remove the black, split grommet (e) from the hole in the center of the armrest weldment.
- 10) From the hole in the center of the armrest weldment, pull the wire harness out of the right armrest weldment.
- 11) Pop out the black dome cap plug (f) from the LEFT armrest tube. Insert it in the hole in the RIGHT armrest tube (hole created by the removal of the bushing in Step No. 2).
- 12) Carefully thread the taped end of the wire harness into the center hole and up the left armrest tube.
- 11) When the taped end becomes visible through the hole in the armrest tube (hole created by removal of the cap plug in Step No. 11), carefully extract the harness using needle-nose pliers.
- 12) Mount the rocker switch housing (c) on the left armrest tube using screw (d) removed in Step No. 5.
- 13) Gently feed the rocker switch wire harness through the back on the rocker switch housing until it comes out the front of the housing.
- 14) Untape the wire harness connectors and connect to the rocker switch.
- 15) Carefully push the rocker switch into the housing until it "snaps" securely into place.
- 16) Reinsert the black, split grommets: 2 in the rocker switch housing and 1 in the center of the armrest weldment.
- 17) Before securing seat cushion, make sure the wire harness will lie in the channel (g) in the bottom of the seat.
- 18) Secure the seat cushion using the (4) Phillips flat head machine screws removed in Step No. 1.

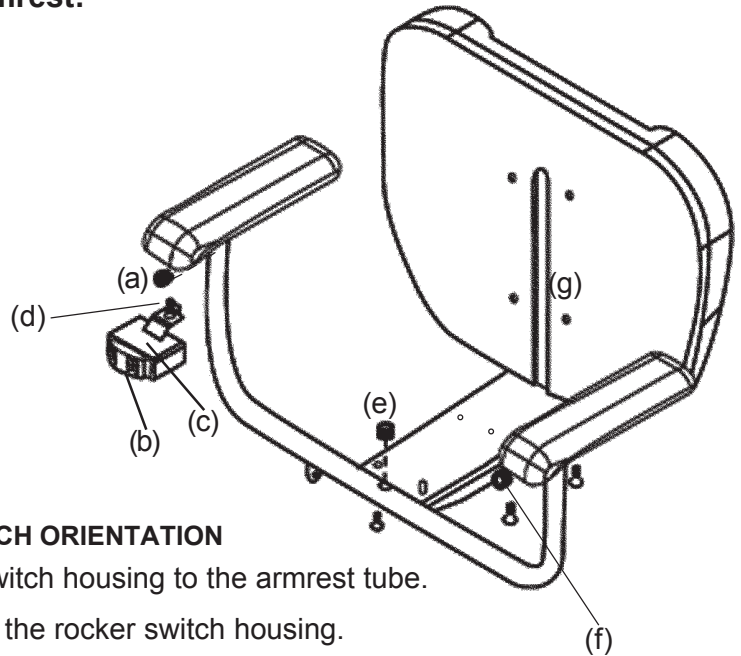

CIRCUIT BREAKER

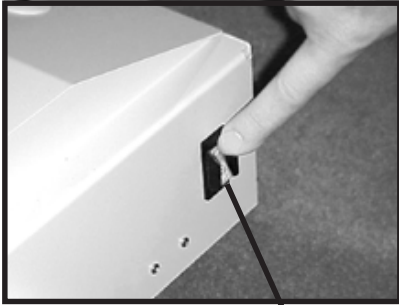

**circuit breaker with
on/off switch built in**

The on/off switch is built into the circuit breaker which is provided to protect the battery, controller and motor circuits in the Elevator carriage. It is unlikely that this circuit breaker will ever “trip” during normal use, but if the Elevator should fail to operate, check the circuit breaker and reset it if necessary. If the circuit breaker should trip, determine the cause and correct the situation.

The most likely cause of a tripped circuit breaker would be a foreign object jamming the rail or gear rack or overloading the elevator by exceeding its rated load capacity.

ELECTRICAL

- APP
- ENG
- IC
- ASM
- SHP
- UPH
- TS
- MAN
- UL

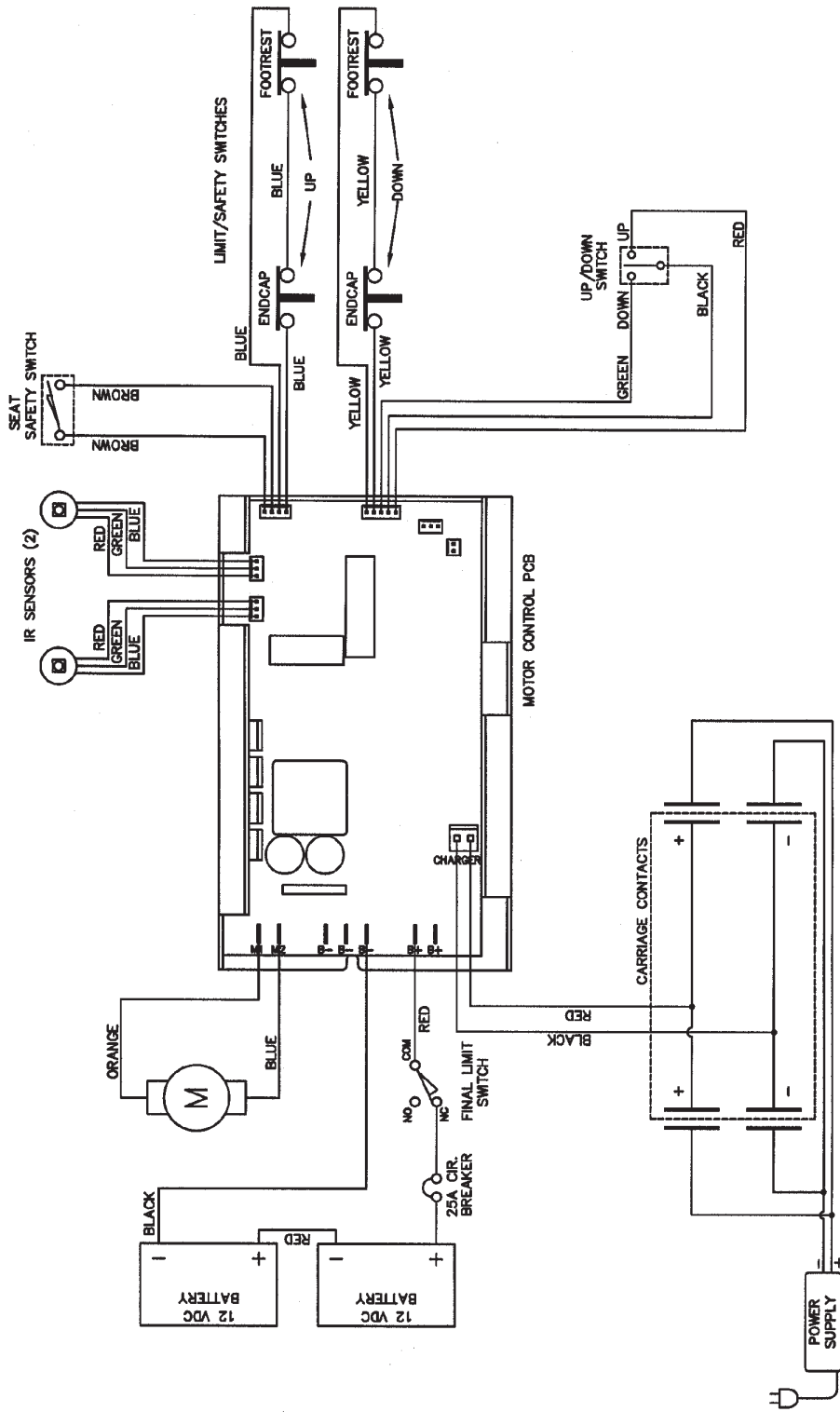

BRUNO
 1700 SECURITY BLVD. #100
 OAKVILLE, ONT. L6M 4G8
 (416) 885-1800
 (FAX) 283-983-5504
 Part used in files of walking aids and
 aids, safety, support or accessories, used herein.

Manufactured at BRUNO plant in SRE-2700
 Design: J.P.P.
 Part Name: **WIRING DIAGRAM**
 Date: 10-16-02
 Drawn by: KAS
 Part No: SCH-0007210

Rev.	Date	By

This document is the property of Bruno Independent Living Aids, Inc. Its rights are reserved to use with, modify, reproduce, or otherwise use in any form (a) product, modification or maintenance of (b) the working of services to Bruno Independent Living Aids, Inc.

LONG-TERM STORAGE

TURNING THE UNIT OFF

When the Elevator will not be in use for an extended period of time:

- 1) move the seat/carriage 2"-3" away from the lower charge contacts,
- 2) turn off the circuit breaker, then
- 3) unplug the power supply from the wall outlet.

DO NOT unplug the power supply from the wall outlet without first turning off the circuit breaker. Failure to first turn off the circuit breaker will result in battery discharge or premature battery failure.

TURNING THE UNIT ON

To turn the Elevator back on:

- 1) turn on the circuit breaker, then
- 2) plug the power supply back into the wall outlet.

NOTE: The batteries may require recharging before normal use if the Elevator has remained in the 'off' position for an extended period of time. To do so, simply move the unit to the LOWER charge contacts, and reconnect the power supply to the wall outlet (circuit breaker 'on').



California Proposition 65 Workplace Warning Sign

1/99

TROUBLESHOOTING

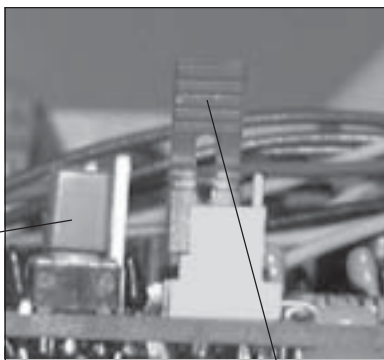
<p>Unit fails to operate</p>	<p>Check circuit breaker, reset if necessary.</p> <p>Check battery connections.</p> <p>Check footrest safety switches to see if one of these limit switches is depressed. Sliding safety tray below footrest should slide freely and should not stick in a position which would depress one of the safety switches.</p> <p>Check for discharged batteries. Battery voltage should be in a range of 21-29 VDC. Unit will "cut out" at 16.5V and will require 21V to restart.</p>
<p>Unit operates slowly, lacks power</p>	<p>Check for discharged batteries.</p> <p>Check for loose connections.</p> <p>Check to make sure power supply is plugged in and working.</p>
<p>Controls operate backwards and unit goes "up" slowly and "down" fast</p>	<p>Check to make sure that jumper is on the left and middle pins. Refer to the section on conversion to Right-Hand Operation.</p> <div data-bbox="341 1491 1429 1953"><p>red button</p><p>jumper covers left and middle pins</p></div>

TROUBLESHOOTING

<p>Unit operates erratically or intermittently with a rider using the armrest-mounted control switch</p>	<p>Check to see that the footrest safety tray is not dragging on the stair nosing or hitting debris on the stairs. Clear debris and, if necessary, reposition the stair rail mounting brackets to correct the problem.</p>
<p>Unit will not operate unless the seat is positioned so that it faces the open side of the stairs</p>	<p>This is correct lift operation, a safety switch in the seat swivel prevents the unit from operating with the seat "out of position".</p>
<p>Unit will not operate with call / send remote transmitter</p>	<p>Check batteries in remote call / send unit. Check IR receiver. Check for loose connection. Check that transmitters are `learned' to the same switch position (see Learning the Transmitter).</p>
<p>Unit does not shut off when it hits the bumper at the end of the rail</p>	<p>Check limit switch in carriage assembly for proper operation.</p>

MAINTENANCE

YEARLY MAINTENANCE OPERATIONS

STAIRWAY ELEVATORS

Clean rail, rack, and wheels.

Apply a small dab of grease to the gear rack **TEETH ONLY**.

Check for dry and/or worn belts. Lubricate.

Check rail wear. There should be no groove.

Clean charging contacts (both carriage and rail ends) with Scotch Brite®.

Check battery voltage (load test).

Check safety switches (footrest, carriage, seat).

Check armrest switch and keyswitch (if applicable).

Check power supply output:

- Load test using remote controls: check voltage while carriage is traveling up.
- Test with carriage against contacts.
- Test with carriage away from contacts.
- Check contacts.

Check speed.

Check seat belt for wear and proper operation.

Examine exposed wiring. Are there any cuts or abrasions?

Verify operation of seat swivel mechanism. Does it move easily and lock in place correctly?

Check that all hardware is properly tightened.

'ELECTRA-RIDE' LT ASSEMBLY

EXPLODED VIEW AND BILL OF MATERIALS

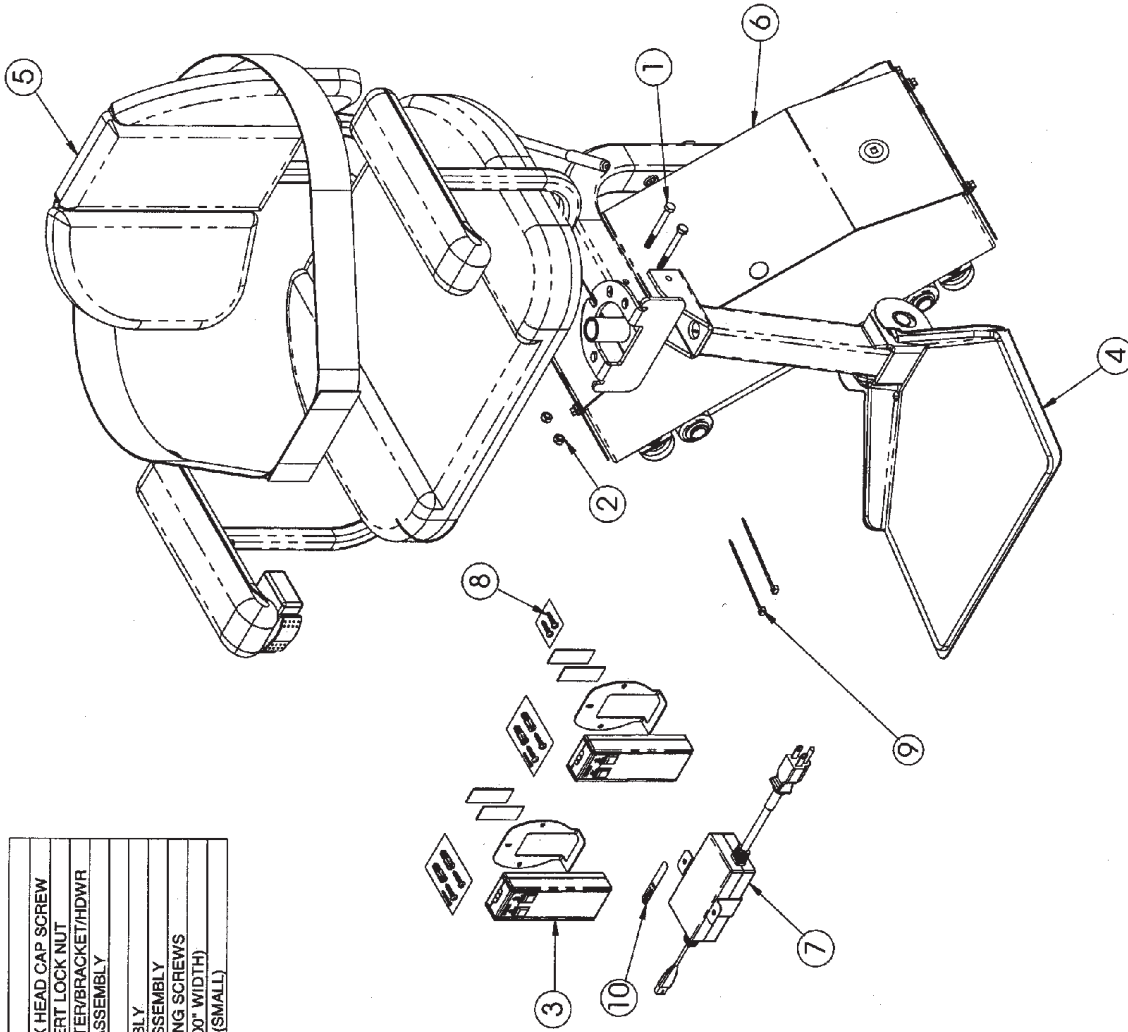

ITEM NO.	QTY.	PART NO.	DESCRIPTION
1	2	MHCS-06006	M6 X 1 X 56MM HEX HEAD CAP SCREW
2	2	MNSN-06100	M6 X 1 NYLON INSERT LOCK NUT
3	2	SRE-00664	STD. IR TRANSMITTER/BRACKET/HDWR
4	1	SRE-27009	FOOTREST TUBE ASSEMBLY
5	1	SRE-27056	SEAT ASSEMBLY
6	1	SRE-27072	CARRIAGE ASSEMBLY
7	1	SRE-27093	POWER SUPPLY ASSEMBLY
8	1	SRE-K-1518	CHARGER MOUNTING SCREWS
9	2	WRT-10001	4" LG. WIRE TIE (100" WIDTH)
10	1	-	SERIAL NO. LABEL (SMALL)



SRE-2700
REV. 1 (2821)(6/9/04)(SMR)

EXPLODED VIEW AND BILL OF MATERIALS

COMPLETE 16' RAIL KIT

ITEM NO.	QTY.	PART NO.	DESCRIPTION
1	1	LUB-00102	LUBRI-PLATE 1.75 OZ. TUBE
2	8	MHCS-12001	M12 X 1.75 X 220MM HEX HEAD CAP SCREW
3	16	SRE-00104CP	TALL CLAMP FOOT
4	16	SRE-00108CP	CLAMP
5	8	SRE-00172	SPACER TUBE
6	1	SRE-27094	BUMPER ASSEMBLY #1
7	1	SRE-27095	BUMPER ASSEMBLY #2
8	1	SRE-27097	FINAL LIMIT RAMP ASSEMBLY
9	1	SRE-K-1501	16' RAIL ELECTRICAL PARTS KIT
10	1	SRE-K-1507	SHEET METAL SCREWS KIT (92)
11	1	SRE-K-1517	CLAMP SET NUTS & WASHERS
12	1	SRE-K-1546	16' RAIL/JOINT PLATE KIT
13	1	SRE-K-1553	BUMPER ASSEMBLY PARTS KIT
14	9	WRT-14402	11" LG. WIRE TIE (.144" WIDTH)

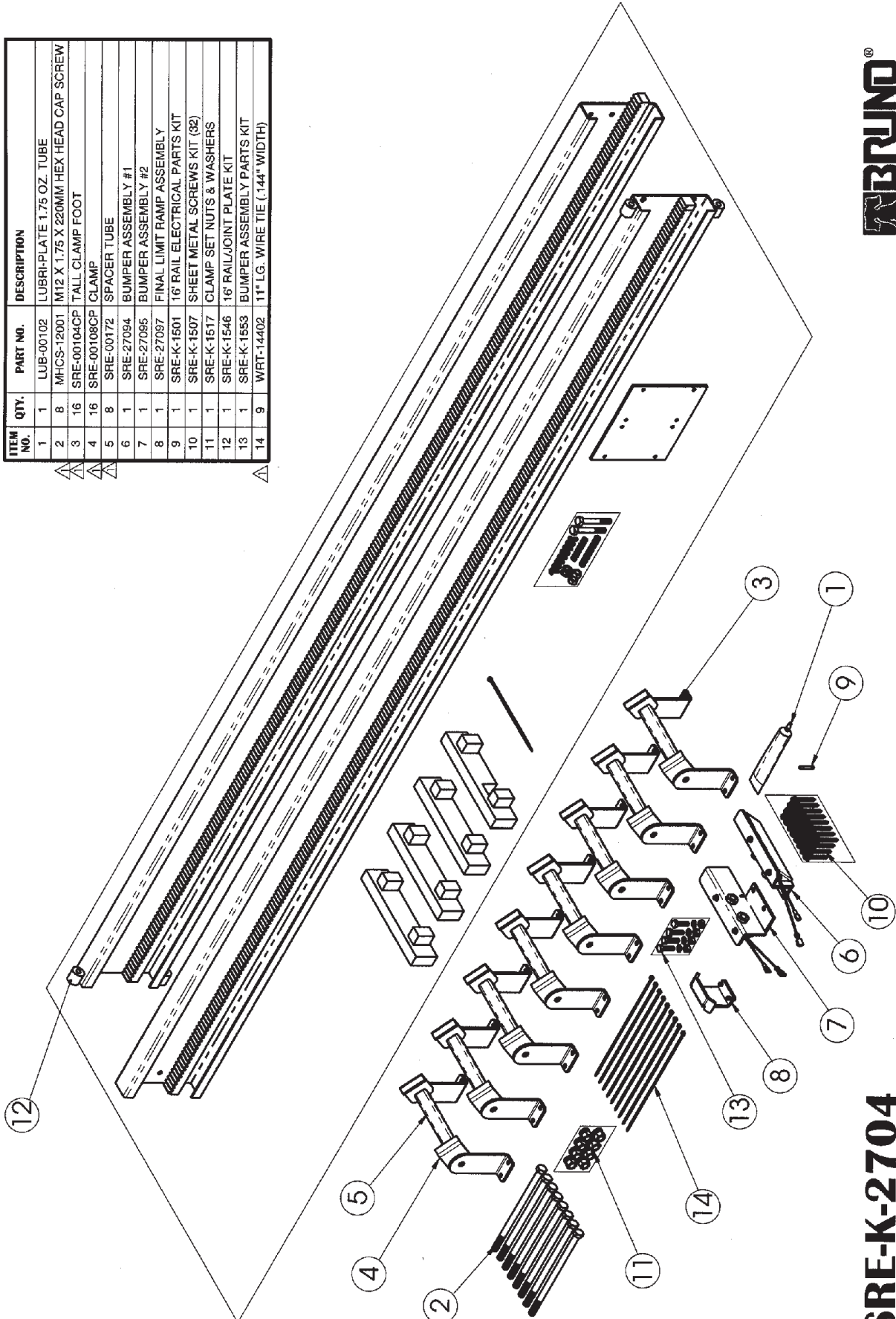

SRE-K-2704
REV. 1 (2808)(5/21/04)(SMR)

EXPLODED VIEW AND BILL OF MATERIALS

COMPLETE 20' RAIL KIT

ITEM NO.	QTY.	PART NO.	DESCRIPTION
1	1	LUB-00102	LUBRI-PLATE 1.75 OZ. TUBE
2	10	MHCS-12001	M12 X 1.75 X 220MM HEX HEAD CAP SCREW
3	2	MITW-12001	M12 INTERNAL TOOTH WASHER
4	2	MINPL-12175	M12 X 1.75 HEX NUT
5	8	MSSM-63001	M6.3 X 50mm LG SLOTTED HEX HEAD SHEET METAL SCREW
6	20	SRE-00104CP	TALL CLAMP FOOT
7	20	SRE-00108CP	CLAMP
8	10	SRE-00172	SPACER TUBE
9	1	SRE-27094	BUMPER ASSEMBLY #1
10	1	SRE-27095	BUMPER ASSEMBLY #2
11	1	SRE-27097	FINAL LIMIT RAMP ASSEMBLY
12	1	SRE-K-1507	SHEET METAL SCREWS KIT (32)
13	1	SRE-K-1517	CLAMP SET NUTS & WASHERS
14	1	SRE-K-1545	20' RAIL/JOINT PLATE KIT
15	1	SRE-K-1553	BUMPER ASSEMBLY PARTS KIT
16	1	SRE-K-2706	20' RAIL ELECTRICAL PARTS KIT
17	11	WRT-14402	11" LG. WIRE TIE (.144" WIDTH)

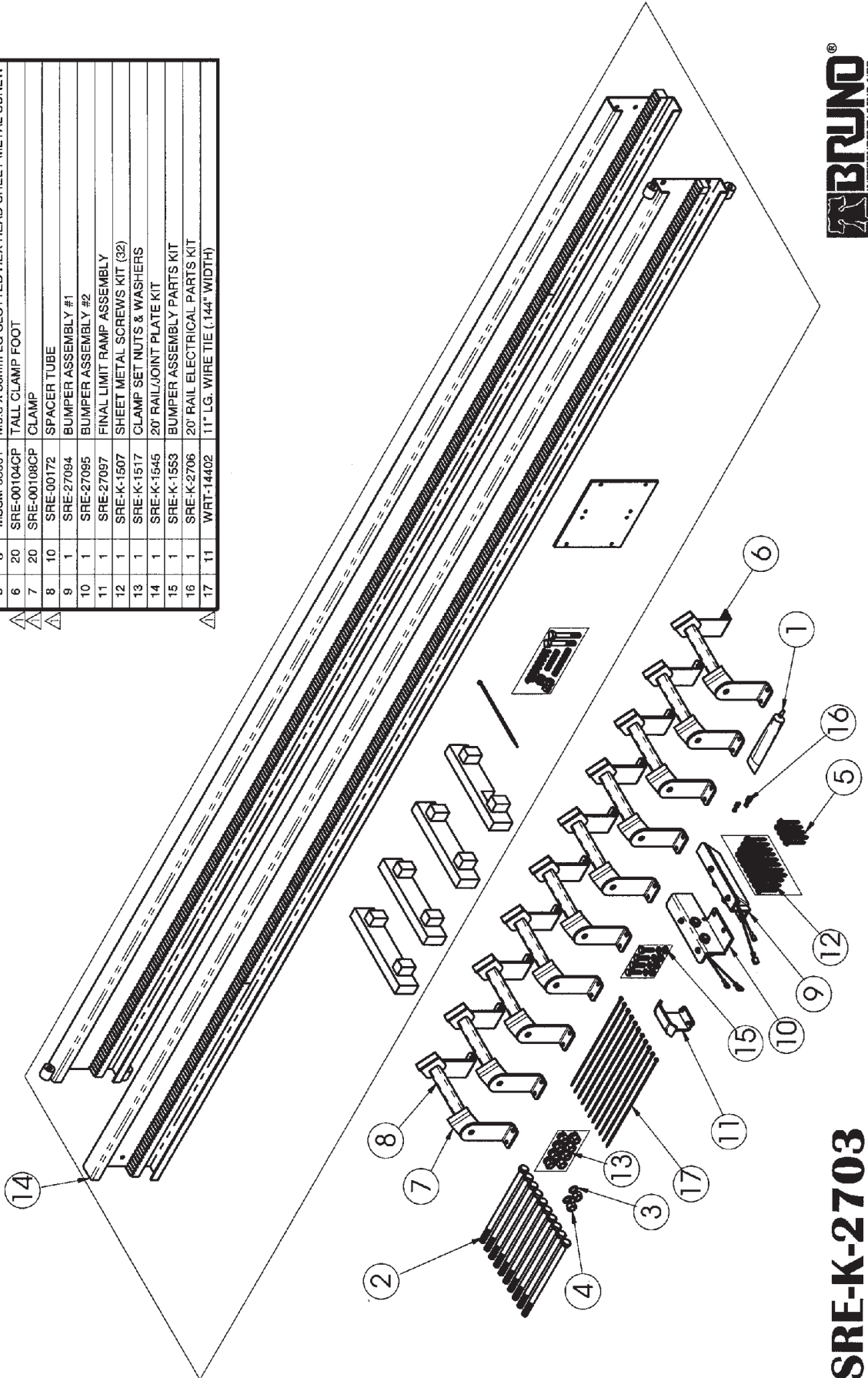

SRE-K-2703
REV. 1 (2808)(5/21/04)(SMR)

EXPLODED VIEW AND BILL OF MATERIALS

COMPLETE 24' RAIL KIT

ITEM NO.	QTY.	PART NO.	DESCRIPTION
1	1	LUB-00102	LUBRI-PLATE 1.75 OZ. TUBE
2	13	MHCS-12001	M12 X 1.75 X 220MM HEX HEAD CAP SCREW
3	5	MITW-12001	M12 INTERNAL TOOTH WASHER
4	5	MNPL-12175	M12 X 1.75 HEX NUT
5	20	MSSM-63001	M6.3 X 50mm LG SLOTTED HEX HEAD SHEET METAL SCREW
6	26	SRE-00104CP	TALL CLAMP FOOT
7	26	SRE-00108CP	CLAMP
8	13	SRE-00172	SPACER TUBE
9	1	SRE-27094	BUMPER ASSEMBLY #1
10	1	SRE-27095	BUMPER ASSEMBLY #2
11	1	SRE-27097	FINAL LIMIT RAMP ASSEMBLY
12	1	SRE-K-1507	SHEET METAL SCREWS KIT (32)
13	1	SRE-K-1517	CLAMP SET NUTS & WASHERS
14	1	SRE-K-1542	24' RAIL/JOINT PLATE KIT
15	1	SRE-K-1553	BUMPER ASSEMBLY PARTS KIT
16	1	SRE-K-2707	24' RAIL ELECTRICAL PARTS KIT
17	13	WRT-14402	11" LG. WIRE TIE (.144" WIDTH)

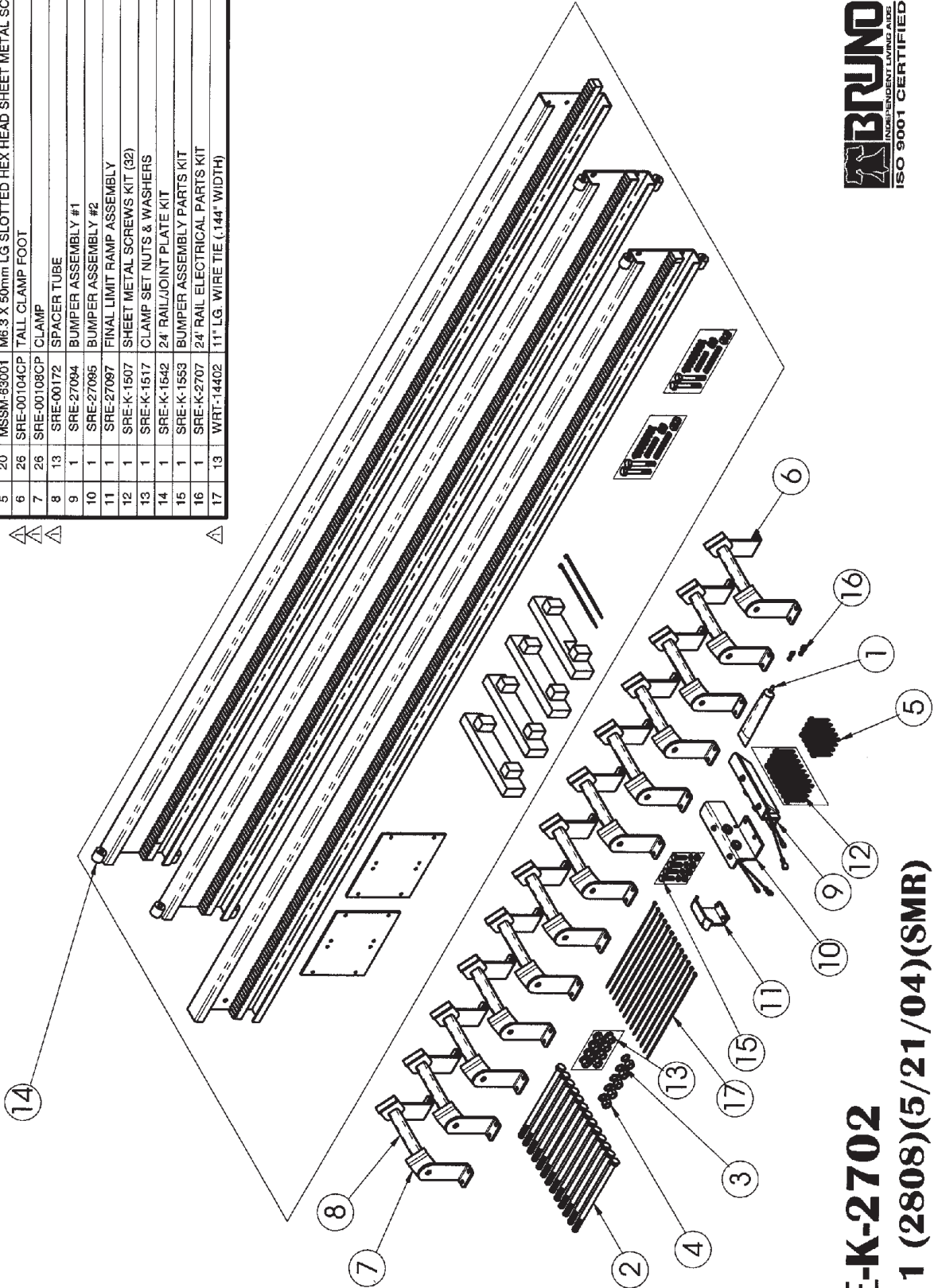

SRE-K-2702
REV. 1 (2808)(5/21/04)(SMR)

EXPLODED VIEW AND BILL OF MATERIALS

SEAT ASSEMBLY

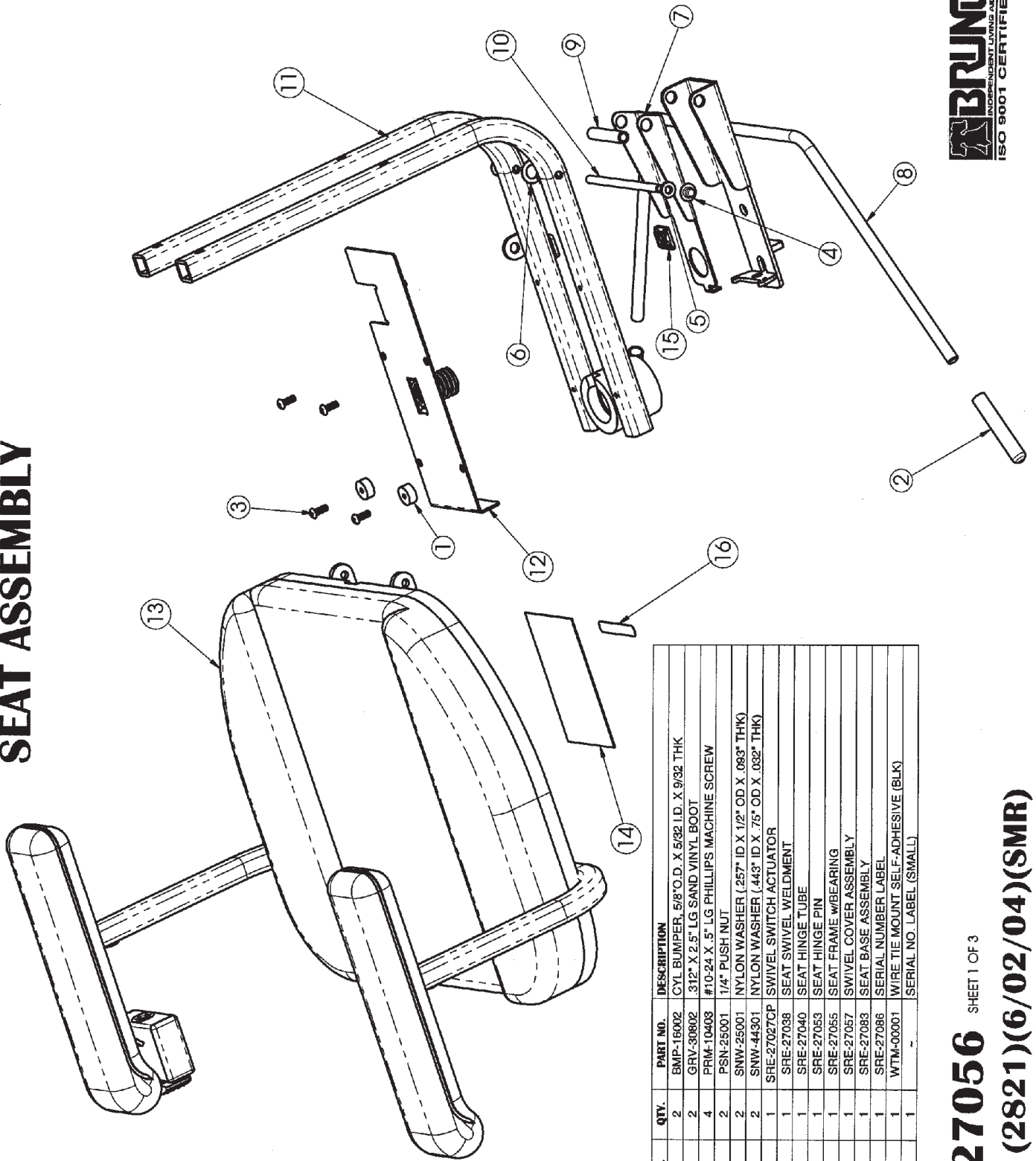

ITEM NO.	QTY.	PART NO.	DESCRIPTION
1	2	BMP-16002	CYL BUMPER, 5/8" O.D. X 5/32" I.D. X 9/32" THK
2	2	GRV-30802	.312" X 2.5" LG SAND VINYL BOOT
3	4	PRM-10403	#10-24 X .5" LG PHILLIPS MACHINE SCREW
4	2	PSN-25001	1/4" PUSH NUT
5	2	SNW-25001	NYLON WASHER (.257" ID X 1/2" OD X .083" THK)
6	2	SNW-44301	NYLON WASHER (.443" ID X .75" OD X .032" THK)
7	1	SRE-27027CP	SWIVEL SWITCH ACTUATOR
8	1	SRE-27038	SEAT SWIVEL WELDMENT
9	1	SRE-27040	SEAT HINGE TUBE
10	1	SRE-27053	SEAT HINGE PIN
11	1	SRE-27055	SEAT FRAME W/BEARING
12	1	SRE-27057	SWIVEL COVER ASSEMBLY
13	1	SRE-27083	SEAT BASE ASSEMBLY
14	1	SRE-27086	SERIAL NUMBER LABEL
15	1	WTM-00001	WIRE TIE MOUNT SELF-ADHESIVE (BLK)
16	1	-	SERIAL NO. LABEL (SMALL)

SRE-27056 SHEET 1 OF 3
REV. 1 (2821)(6/02/04)(SMR)

EXPLODED VIEW AND BILL OF MATERIALS

SEAT ASSEMBLY

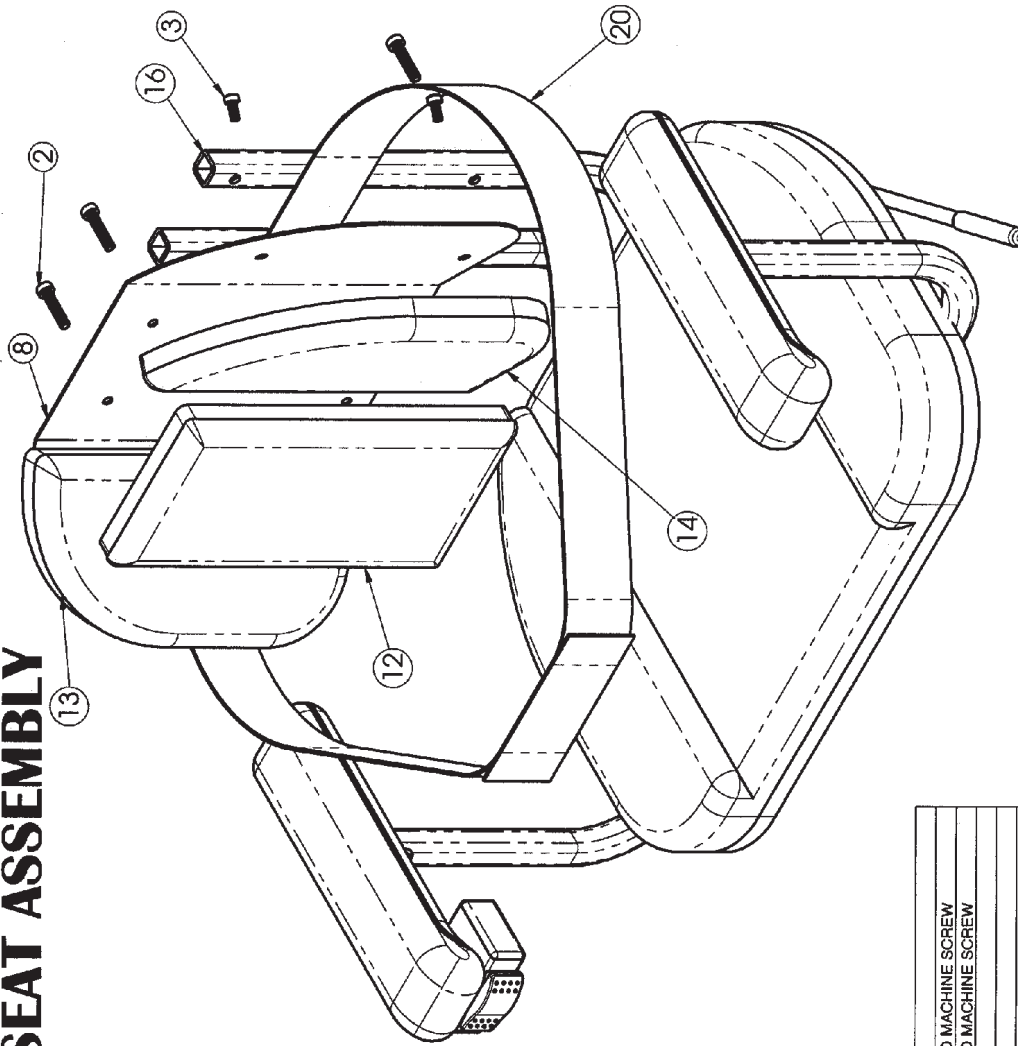

ITEM NO.	QTY.	PART NO.	DESCRIPTION
2	4	MPLM-06006	M6 X 1 X 30mm LG PHILLIPS FILLISTER HEAD MACHINE SCREW
3	4	MPLM-08008	M6 X 1 X 12mm LG PHILLIPS FILLISTER HEAD MACHINE SCREW
8	1	SRE-27013CP	SEAT BACK PAN
12	1	SRE-27045	SEAT BACK PANEL
13	1	SRE-27046	LEFT SEAT BACK PANEL
14	1	SRE-27047	RIGHT SEAT BACK PANEL
16	1	SRE-27065	SEAT FRAME W/BEARING
20	1	SRE-27091	SEAT RESTRAINT



SRE-27056 SHEET 2 OF 3
REV. 1 (2821)(6/02/04)(SMR)

SEAT ASSEMBLY

ITEM NO.	QTY.	PART NO.	DESCRIPTION
3	1	MHCS-08001	M8 X 1.25 X 50MM HEX HEAD CAP SCREW (FULL THREAD)
4	1	MHCS-08004	M8 X 1.25 X 40mm LG HEX HED CAP SCREW
5	2	MNSN-08125	M8 X 1.25 NYLON INSERT LOCK NUT
11	6	SNW-39401	NYLON WASHER (.394" ID X .785" OD X .080" THK)
13	1	SPR-00028	SEAT HOLD-UP COMPRESSION SPRING
14	1	SRE-00471	OUTER SPRING HOUSING
15	1	SRE-00472	INNER SPRING HOUSING
16	1	SRE-00475	INNER SPRING HOUSING MNTG. SPACER
17	1	SRE-00476	OUTER SPRING HOUSING MNTG. SPACER

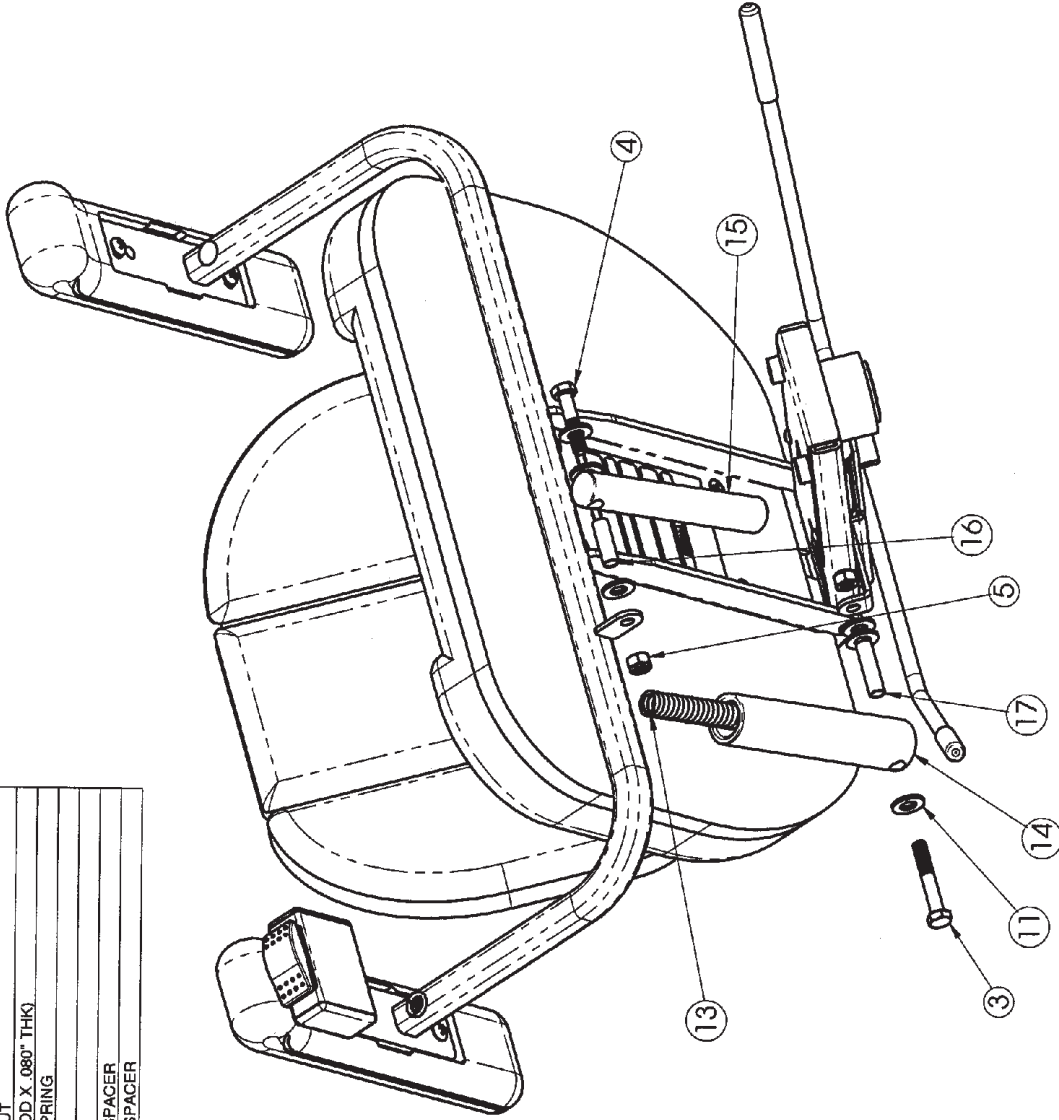

SRE-27056 SHEET 3 OF 3
REV. 1 (2821)(6/02/04)(SMR)

EXPLODED VIEW AND BILL OF MATERIALS

SEAT BASE ASSEMBLY

ITEM NO.	QTY.	PART NO.	DESCRIPTION
1	2	BUS-50005	Ø5/8" OPEN/CLOSED BUSHING
2	1	BUS-69002	Ø5/8" OPEN/CLOSED BUSHING
3	2	CPP-10201	1" X 2" RECTANGULAR CAP PLUG (18 GA)
4	1	CPP-50001	3/8" X 1/8" PANEL THK. DOME CAP PLUG
5	4	MPFM-06001	M6 X 1 X 16mm LG PHILLIPS FLAT HEAD MACHINE SCREW
6	4	PRM-26003	1/4-20 X .75" LG PHILLIPS ROUND HEAD MACHINE SCREW
7	1	RSW-00104	SPDT MOMENTARY ROCKER SWITCH
8	1	SRE-00577	SWITCH BRACKET WELDMENT
9	1	SRE-27030	ARM REST WELDMENT
10	1	SRE-27044	SEAT CUSHION
11	1	SRE-27070	ROCKER SWITCH HARNESS
12	2	Z-022-020	URETHANE ARMREST

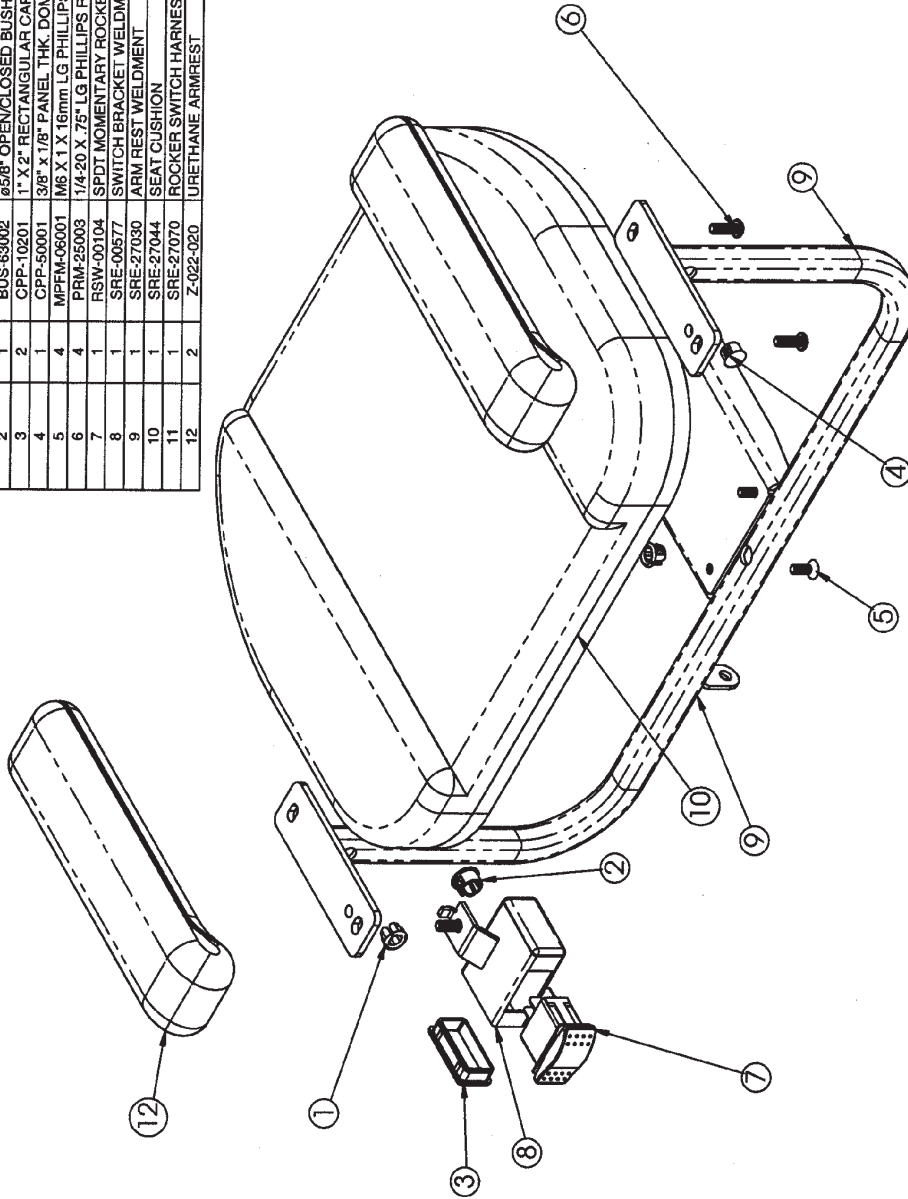

SRE-27070 ROCKER SWITCH HARNESS

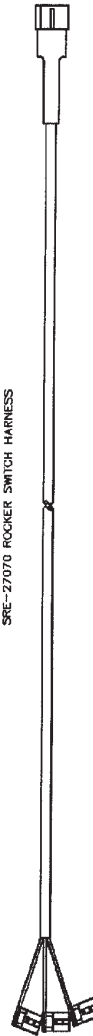

SRE-27083
REV. 0 (ISSUED 9/16/02)



EXPLODED VIEW AND BILL OF MATERIALS

SEAT TUBE ASSEMBLY

ITEM NO.	QTY.	PART NO.	DESCRIPTION
1	2	ASP-16602	5/16" OD X .187" LG #8 ALUMINUM SPACER
2	1	BUS-50005	.65/8" OPEN/CLOSED BUSHING
3	2	ITW-06001	#6 INTERNAL TOOTH WASHER
4	1	MEC-00117	4 CIRCUIT (MALE) .062 CONNECTOR HOUSING
5	1	MEC-00122	3 CIRCUIT (MALE) .062 CONNECTOR HOUSING
6	1	MEC-00125	2 CIRCUIT (FEMALE) .062 CONNECTOR HOUSING
7	2	MHCS-14006	M14 X 2 X 70MM LG HEX HEAD CAP SCREW
8	2	MITW-14001	M14 INTERNAL TOOTH WASHER
9	2	MNSN-03051	M3 X .5 NYLON INSERT LOCK NUT
10	2	MPLM-03003	M3 X .5 X 30MM LG PHILLIPS FILLISTER HEAD MACHINE SCREW
11	2	MSLW-14001	M14 SAFETY LOCK WASHER
12	4	MJNT-05001	M5 X .8 UNUT (BLACK)
13	1	PBS-00107	SPDT PUSHBUTTON SWITCH (SNAP-ACTION w/ROLLER LEVER)
14	1	SRE-00611	MOTOR MOUNT STABILIZER
15	1	SRE-00605	FINAL LIMIT SWITCH HARNESS #1
16	1	SRE-27000	ADJUSTMENT BRACKET
17	2	SRE-27003	SEAT SUPPORT TUBE SPACER
18	1	SRE-27006	ANGLE RETAINER
19	1	SRE-27008	SEAT TUBE WELDMENT
20	1	SRE-27010	BACK COVER
21	1	SRE-27063	SEAT SWIVEL INTERCONNECT HARNESS
22	1	SRE-27069	FINAL LIMIT SWITCH HARNESS #2

USE ONE PIECE OF SRE-00611, CUT INTO FOUR PIECES AND PLACE AS SHOWN

TORQUE TO 80FT/LBS

FOUR CUT PIECES OF SRE-00611

REMOVE WIRE CUPS (2) & DISCARD

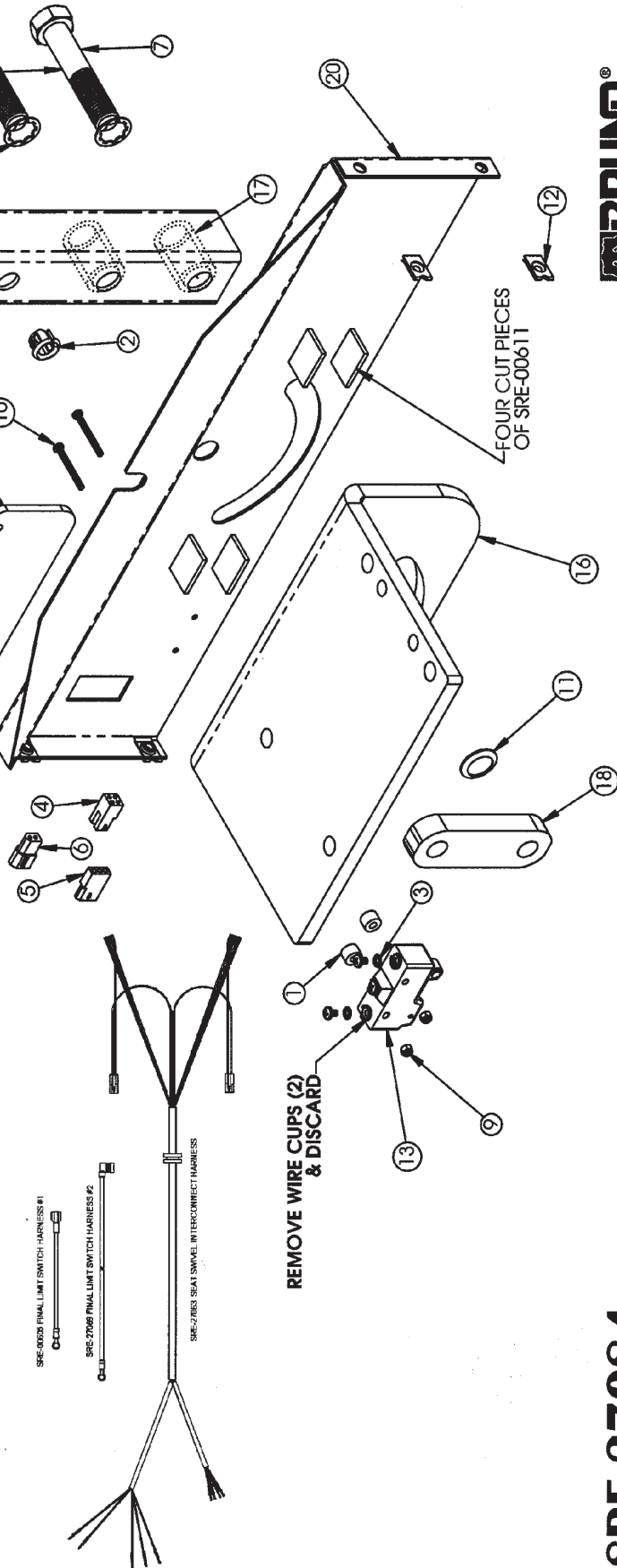

SRE-27084
REV. 1 (2446)(12/3/02)(JWW)

EXPLODED VIEW AND BILL OF MATERIALS

CARRIAGE BASE ASSEMBLY

ITEM NO.	QTY.	PART NO.	DESCRIPTION
1	12	FSW-63003	5/8" I.D. X 1" O.D. X .062" THK FLAT WASHER
2	2	PBS-00102	SPST NC PUSHBUTTON SWITCH (.75A SCREW TERMINALS)
3	6	RTR-63002	5/8" RETAINING RING (EXTERNAL/HEAVY DUTY)
4	4	SNW-62501	.625" ID X .937" OD X .083" THK NYLON WASHER
5	2	SRE-00088	POSITIVE CHARGE CONTACT ASSEMBLY
6	2	SRE-00089	NEGATIVE CHARGE CONTACT ASSEMBLY
7	6	SRE-20119	CARRIAGE WHEEL w/BEARING
8	1	SRE-27004	CARRIAGE WELDMENT
9	1	SRE-27060	LOWER LIMIT SWITCH HARNESS
10	1	SRE-27061	UPPER LIMIT SWITCH HARNESS
11	4	WRT-14401	8" LG. WIRE TIE (.195" WIDTH)

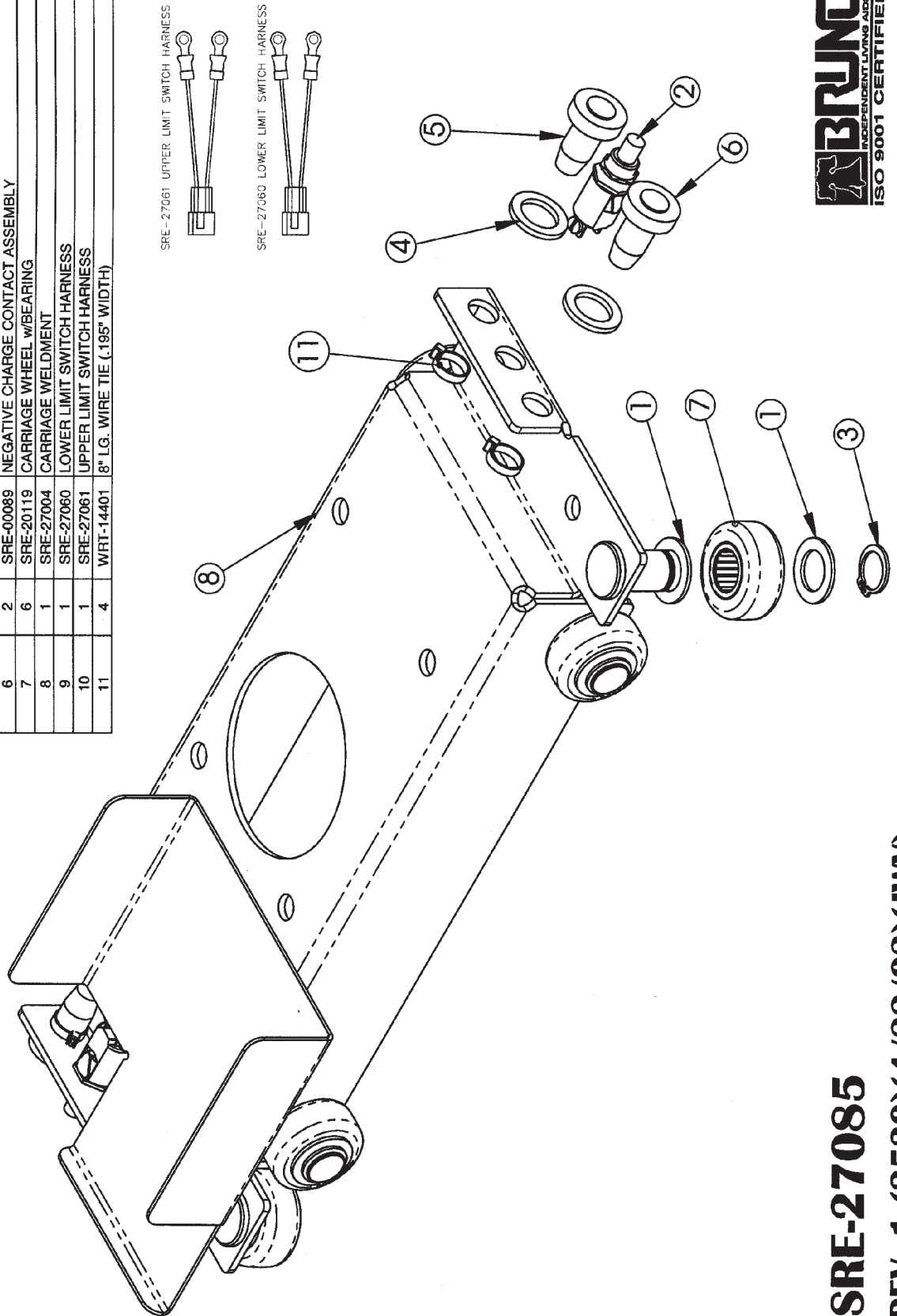

SRE-27085
REV. 1 (2539)(4/22/03)(JWV)

EXPLODED VIEW AND BILL OF MATERIALS

SWIVEL COVER ASSEMBLY

ITEM NO.	QTY.	PART NO.	DESCRIPTION
1	2	MNSN-03051	M3 X .5 NYLON INSERT LOCK NUT
2	2	MPBM-03001	M3 X .5 X 16mm LG PHILLIPS BINDING HEAD MACHINE SCREW
3	1	PBS-00118	SPDT PUSHBUTTON SWITCH (SNAP ACTION) 25A .250 QW.D.
4	1	SPR-00058	FREEWHEEL COMPRESSION SPRING
5	1	SRE-27032CP	SWIVEL COVER
6	1	SRE-27062	SEAT SAFETY SWITCH HARNESS

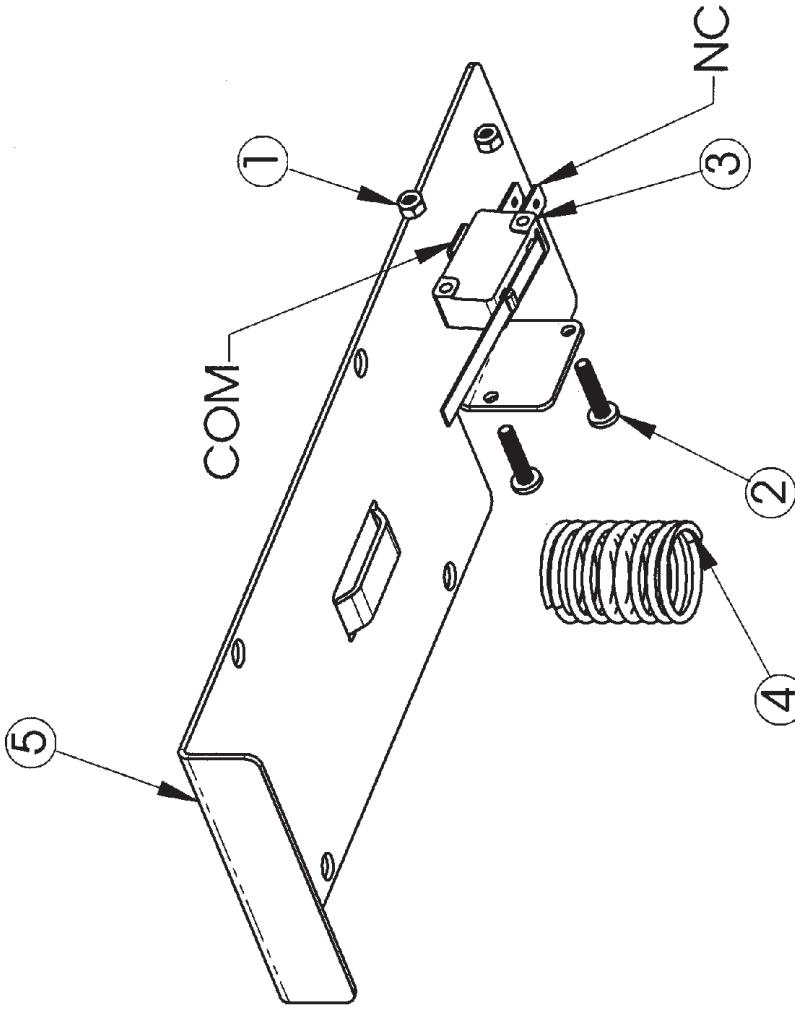

SRE-27062 SEAT SAFETY SWITCH HARNESS

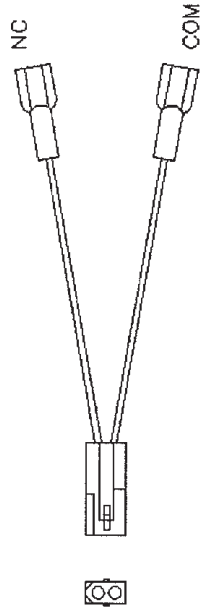

SRE-27057
REV. 2 (2821)(6/9/04)(SMR)

COVER ASSEMBLY

ITEM NO.	QTY.	PART NO.	DESCRIPTION
1	1	CPP-63003	5/8" 'PRY-OUT' CAP PLUG - BLACK
2	4	GRR-19001	3/16" ID RUBBER GROMMET
3	4	MHWH-05001	M5 X .8 X 16mm LG HEX WASHER HEAD MACHINE SCREW
4	4	MNSN-05081	M5 X .8 NYLON INSERT LOCK NUT
5	2	RCV-24003	I.R. RECEIVER WITH CABLES (CSE-125)
6	1	SRE-27041	COVER WELDMENT
7	1	SRE-27043L	SAFETY PANEL (LEFT)
8	1	SRE-27043R	SAFETY PANEL (RIGHT)
9	5	WRT-14401	6" LG. WIRE TIE (.144" WIDTH)
10	2	WTM-00001	WIRE TIE MOUNT SELF-ADHESIVE (BLK)

NOTE: USE FIX-00288 TO LOCATE ITEM #10

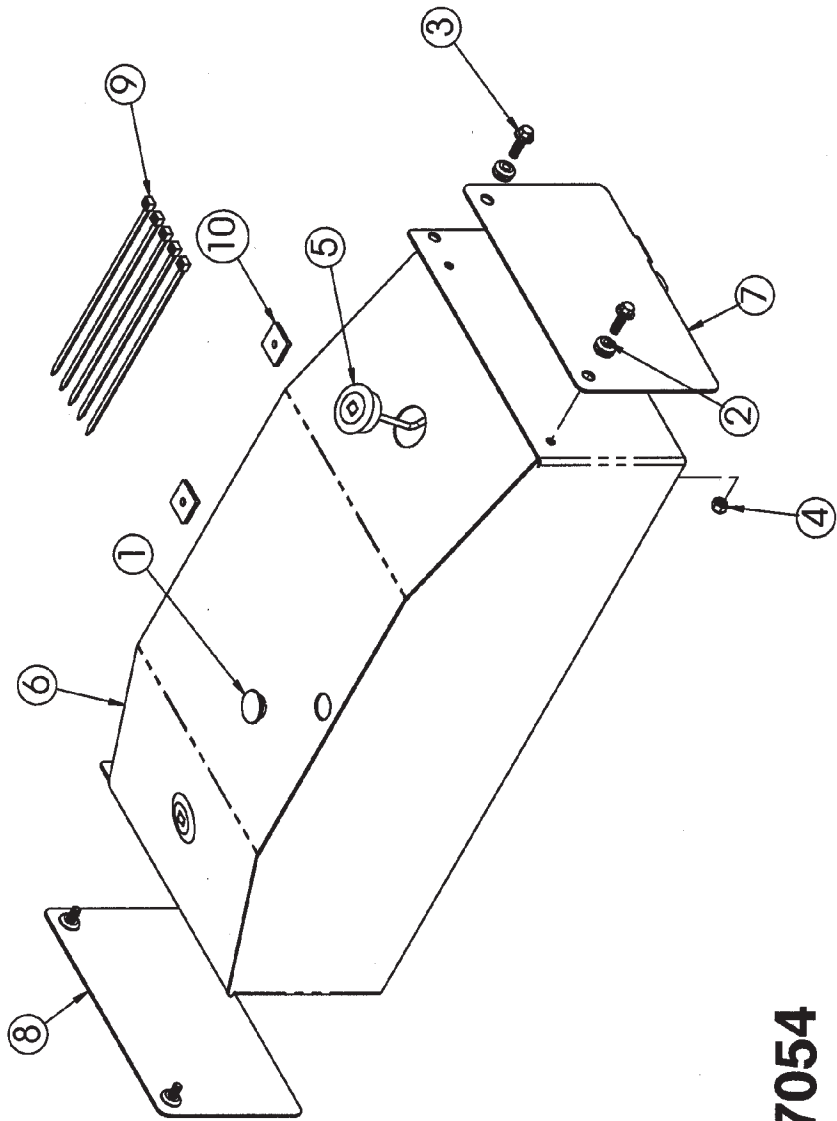

SRE-27054
REV. 0 (ISSUED 9/15/02)

EXPLODED VIEW AND BILL OF MATERIALS

FOOTREST TUBE ASSEMBLY

ITEM NO.	QTY.	PART NO.	DESCRIPTION
1	2	MCLN-10150	M10 X 1.5 HEX CENTER LOCK NUT
2	2	MHCS-10001	M10 X 1.5 X 25mm LG HEX HEAD CAP SCREW
3	3	MPLM-06008	M6 X 1 X 12mm LG PHILLIPS FILLISTER HEAD MACHINE SCREW
4	3	NSW-25401	.254" DIA. NYLON SHOULDER WASHER
5	2	PBS-00102	SPST NC PUSHBUTTON SWITCH (.75A SCREW TERMINAL)
6	2	~	HEXAGON LOCKNUT (PBS-00102)
7	4	~	TERMINAL SCREW (PBS-00102)
8	2	~	HEXAGON FACENUT (PBS-00102)
9	2	SAE-38001	3/8" SAE WASHER
10	4	SNW-39401	NYLON WASHER (.394" ID X .785" OD X .080" THK)
11	1	SRE-00428	FOOTREST
12	1	SRE-00514	FOOTREST COVER (11")
13	1	SRE-27028	11" FOOTREST SAFETY PAN
14	1	SRE-27028	FOOTREST WELDMENT
15	1	SRE-27064	FOOTREST SAFETY SWITCH HARNESS
16	1	~	SERIAL NO. LABEL (SMALL)

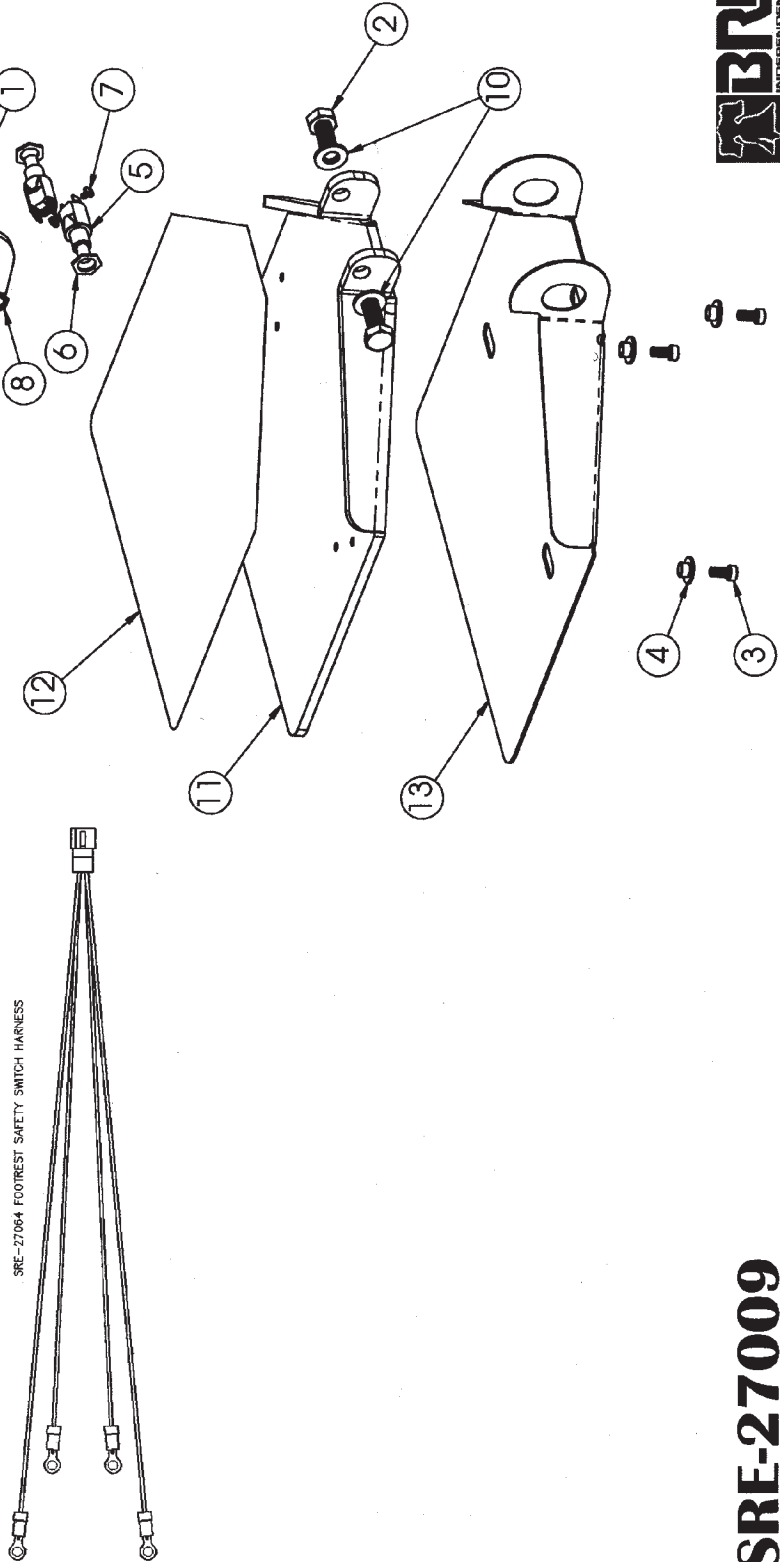

SRE-27009

REV. 2 (2708)(2-18-04)(RJH)

EXPLODED VIEW AND BILL OF MATERIALS

BUMPER ASSEMBLY #1

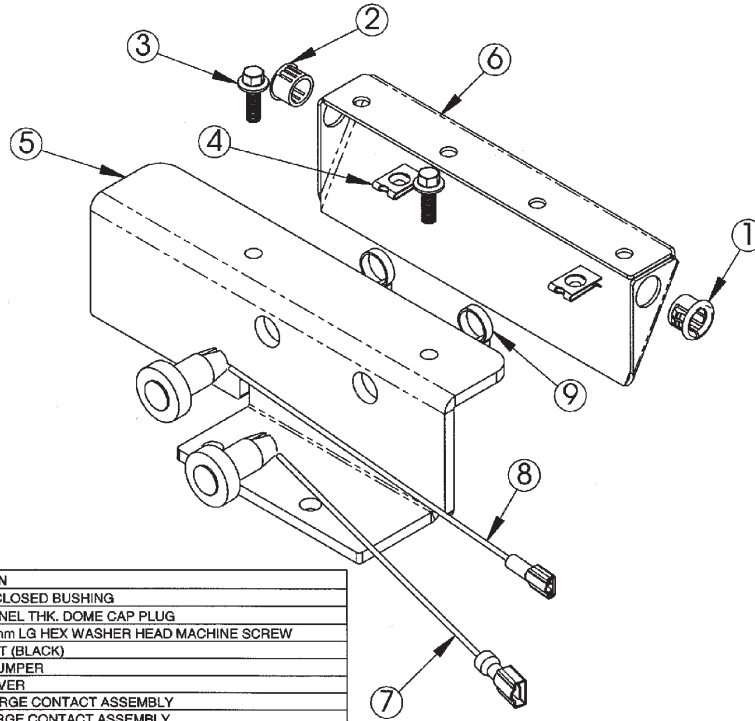

ITEM NO.	QTY.	PART NO.	DESCRIPTION
1	1	BUS-50005	ø5/8" OPEN/CLOSED BUSHING
2	1	CPP-50001	3/8" x 1/8" PANEL THK. DOME CAP PLUG
3	2	MHWH-05001	M5 X .8 X 16mm LG HEX WASHER HEAD MACHINE SCREW
4	2	MUNT-05001	M5 X .8 U-NUT (BLACK)
5	1	SRE-00421L	LEFT RAIL BUMPER
6	1	SRE-00429	BUMPER COVER
7	1	SRE-27058	(+) RAIL CHARGE CONTACT ASSEMBLY
8	1	SRE-27059	(-) RAIL CHARGE CONTACT ASSEMBLY
9	2	WRT-14401	8" LG. WIRE TIE (.195" WIDTH)

SRE-27094

REV. 0 (ISSUED 9/16/02)



BUMPER ASSEMBLY #2

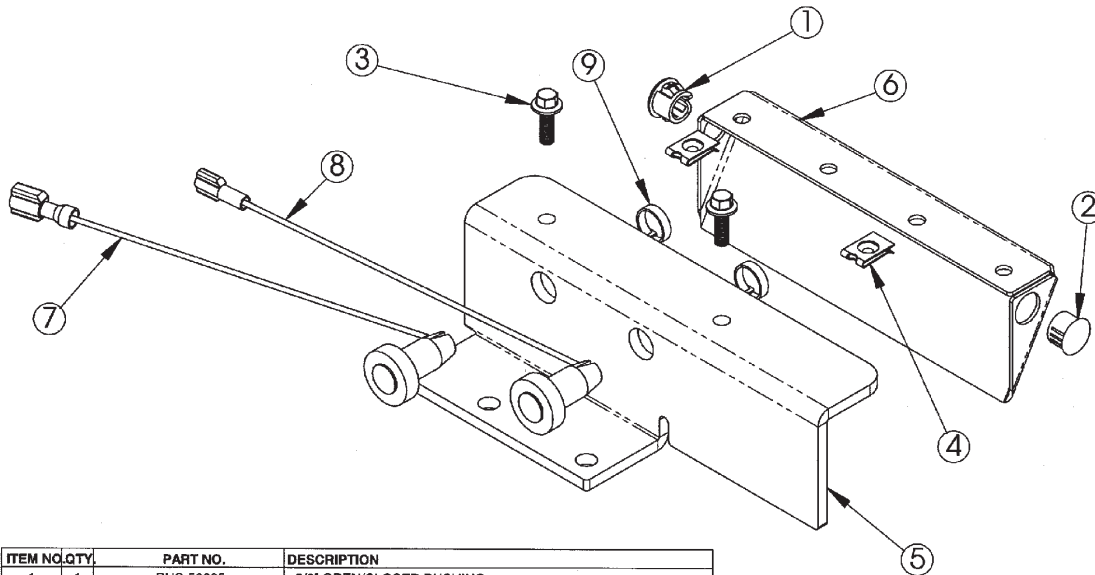

ITEM NO.	QTY.	PART NO.	DESCRIPTION
1	1	BUS-50005	ø5/8" OPEN/CLOSED BUSHING
2	1	CPP-50001	3/8" x 1/8" PANEL THK. DOME CAP PLUG
3	2	MHWH-05001	M5 X .8 X 16mm LG HEX WASHER HEAD MACHINE SCREW
4	2	MUNT-05001	M5 X .8 U-NUT (BLACK)
5	1	SRE-00421R	RIGHT RAIL BUMPER
6	1	SRE-00429	BUMPER COVER
7	1	SRE-27058	(+) RAIL CHARGE CONTACT ASSEMBLY
8	1	SRE-27059	(-) RAIL CHARGE CONTACT ASSEMBLY
9	2	WRT-14401	8" LG. WIRE TIE (.195" WIDTH)

SRE-27095

REV. 0 (ISSUED 9/16/02)



EXPLODED VIEW AND BILL OF MATERIALS

FINAL LIMIT RAMP ASSEMBLY

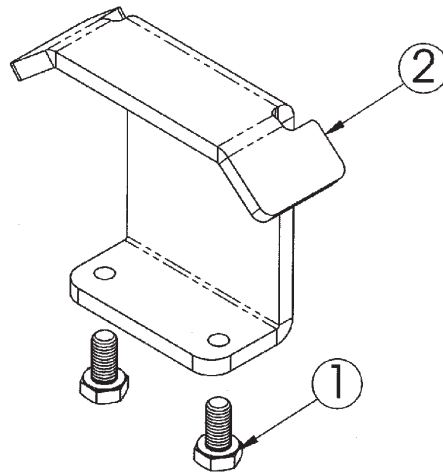

ITEM NO.	QTY	PART NO.	DESCRIPTION
1	2	MHCS-06003	M6 X 1 X 12mm LG HEX HEAD CAP SCREW
2	1	SRE-27037	FINAL LIMIT RAMP

SRE-27097

REV. 0 (ISSUED 9/16/02)



TRANSMITTER ASSEMBLY

ITEM NO.	QTY	PART NO.	DESCRIPTION
1	1	BTR-09001	9V ALKALINE BATTERY
2	1	DEC-00193	UP/DOWN SWITCH COVER
3	1	TMR-09003	9 VDC IR TRANSMITTER W/LT. GRAY SWITCH CAPS (CSE-125)
4	1	-	SERIAL NO. LABEL (SMALL)

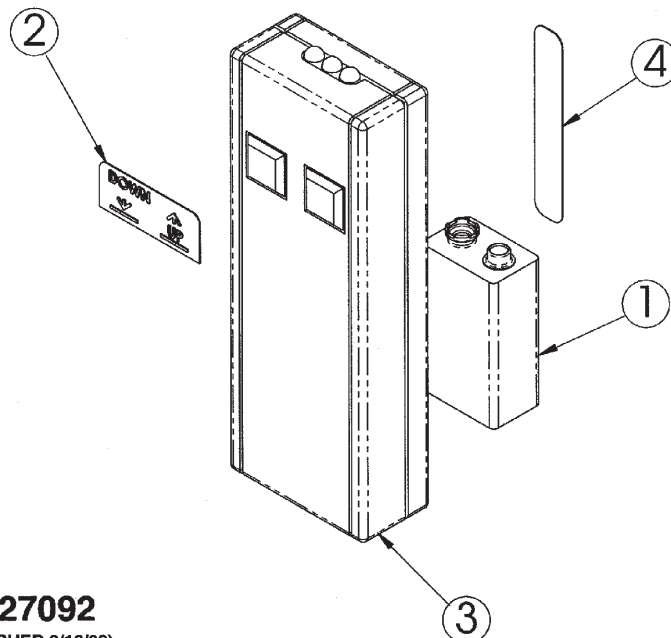

SRE-27092

REV. 0 (ISSUED 9/16/02)



SRE-2700 STD. DISPLAY W/44" RAIL

EXPLODED VIEW AND BILL OF MATERIALS

ITEM NO	QTY	PART NO.	DESCRIPTION	ITEM NO	QTY	PART NO.	DESCRIPTION
1	1	DSP-00047L	STEP SUPPORT WELDMENT LEFT	12	4	MHCS-08002	M8 X 1.25 X 20mm LG HEX HEAD CAP SCREW
2	1	DSP-00047R	STEP SUPPORT WELDMENT RIGHT	13	4	MNPL-08125	M8 X 1.25 METRIC HEX NUT
3	4	DSP-00052	20" VERTICAL SUPPORT TUBE	14	6	NSN-38161	3/8-16 NYLON INSERT LOCK NUT
4	1	DSP-00073	PLATFORM WELDMENT	15	25	SHT-12101	#12-11 X 1.25" SLOTTED HEX HEAD SELF-TAPPING SCREW
5	2	DSP-00078	28" DISPLAY CARPETED STEP	16	1	SRE-00513	STRAIGHT RAIL FINAL ASSEMBLY WELDMENT (4)
6	1	DSP-00080	28" DISPLAY CARPETED TOP STEP	17	2	SRE-00579	TALL CLAMP SET ASSEMBLY
7	1	DSP-00081	28" CARPETED DISPLAY PLATFORM	18	1	SRE-27094	BUMPER ASSEMBLY #1
8	12	FSW-38001	3/8" FLAT WASHER	19	1	SRE-27095	BUMPER ASSEMBLY #2
9	6	HCS-38609	3/8-16 X 2.5" LG HEX HEAD CAP SCREW	20	1	SRE-27097	FINAL LIMIT RAMP ASSEMBLY
10	1	LUB-00102	LUBRI-PLATE 1.75 OZ. TUBE	21	1	SRE-K-2708	4' RAIL ELECTRICAL PARTS KIT
11	4	IMETW-08001	M8 EXTERNAL TOOTH WASHER				

NOTE: HARDWARE LISTED MAKES UP DSP-K-1500

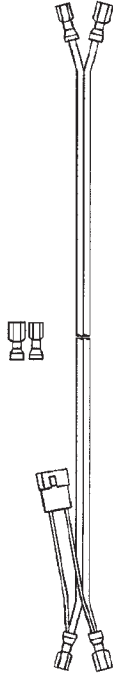

SRE-K-2708 4' RAIL ELECTRICAL PARTS KIT

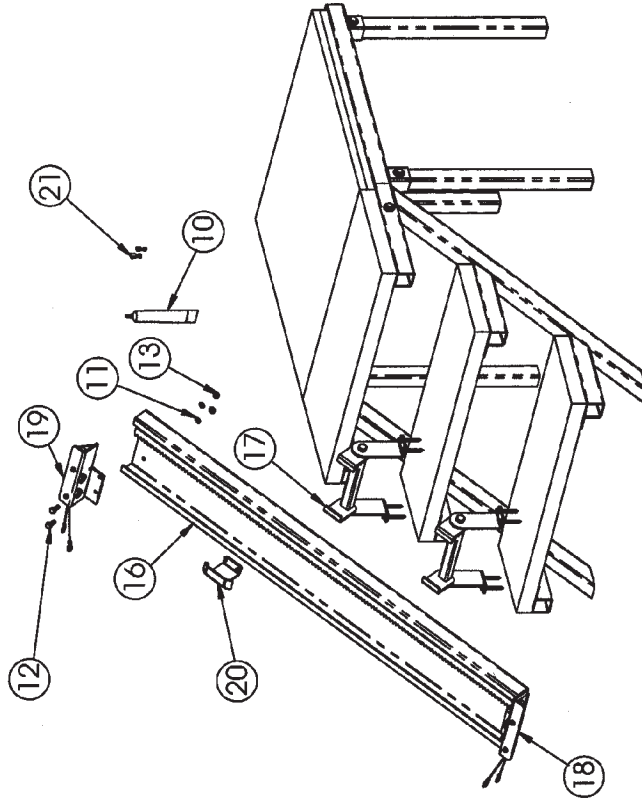
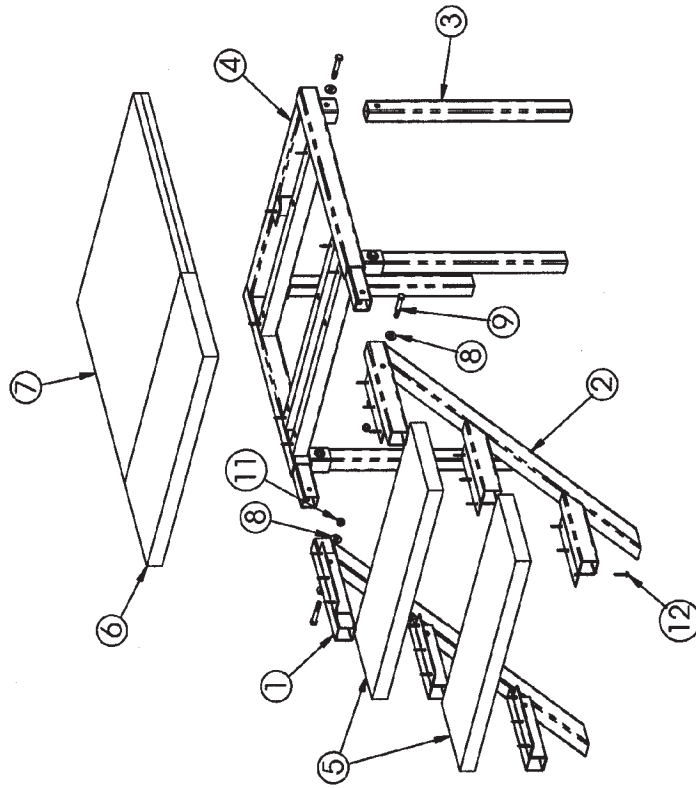

DSP-A-2701
REV. 0 (ISSUED 9/15/02)

EXPLODED VIEW AND BILL OF MATERIALS

SRE-2700 ROLLING DISPLAY w/44" RAIL

ITEM NO.	QTY.	PART NO.	DESCRIPTION	ITEM NO.	QTY.	PART NO.	DESCRIPTION
1	1	DSP-00047L	STEP SUPPORT WELDMENT LEFT	16	4	MNPL-08125	M8 X 1.25 METRIC HEX NUT
2	1	DSP-00047R	STEP SUPPORT WELDMENT RIGHT	17	4	MSSM-55001	M5.5 X 19mm LG SLOTTED HEX HEAD SHEET METAL SCREW
3	4	DSP-00052	20" VERTICAL SUPPORT TUBE	18	6	NSN-38161	3/8-16 NYLON INSERT LOCK NUT
4	1	DSP-00073	PLATFORM WELDMENT	19	25	SHT-12101	#12-11 X 1.25" SLOTTED HEX HEAD SELF-TAPPING SCREW
5	2	DSP-00078	28" DISPLAY CARPETED STEP	20	1	SRE-00513	STRAIGHT RAIL FINAL ASSEMBLY WELDMENT (4')
6	1	DSP-00080	28" DISPLAY CARPETED TOP STEP	21	2	SRE-00579	TALL CLAMP SET ASSEMBLY
7	1	DSP-00081	28" CARPETED DISPLAY PLATFORM	22	1	SRE-27094	BUMPER ASSEMBLY #1
8	2	DSP-00086	WHEEL SUPPORT ASSEMBLY	23	1	SRE-27095	BUMPER ASSEMBLY #2
9	2	DSP-00096	HANDLE ASSEMBLY	24	1	SRE-27097	FINAL LIMIT RAMP ASSEMBLY
10	1	DSP-00120	BATTERY CHARGER MOUNTING BRACKET	25	1	SRE-K-2708	4' RAIL ELECTRICAL PARTS KIT
11	12	FSW-38001	3/8" FLAT WASHER				
12	6	HCS-38608	3/8-16 X 2.5" LG HEX HEAD CAP SCREW				
13	1	LUB-00102	LUBRI-PLATE 1.75 OZ. TUBE				
14	4	METW-08001	M8 EXTERNAL TOOTH WASHER				
15	4	MHCS-08002	M8 X 1.25 X 20mm LG HEX HEAD CAP SCREW				

NOTE: HARDWARE LISTED MAKES UP DSP-K-1525

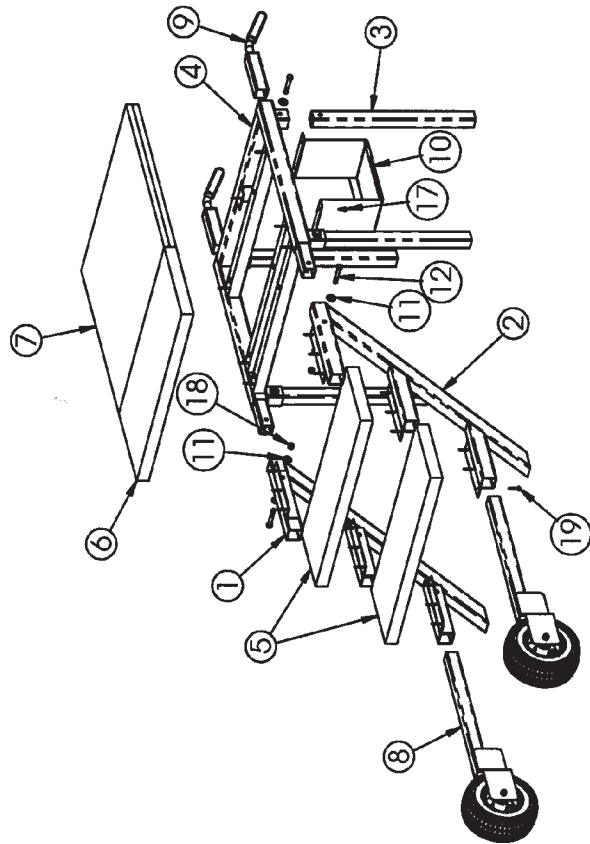

DSP-A-2702
REV. 0 (ISSUED 9/15/02)

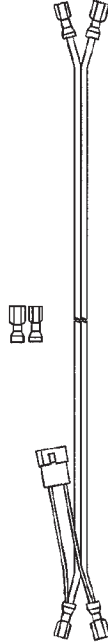

SRE-K-2708 4' RAIL ELECTRICAL PARTS KIT

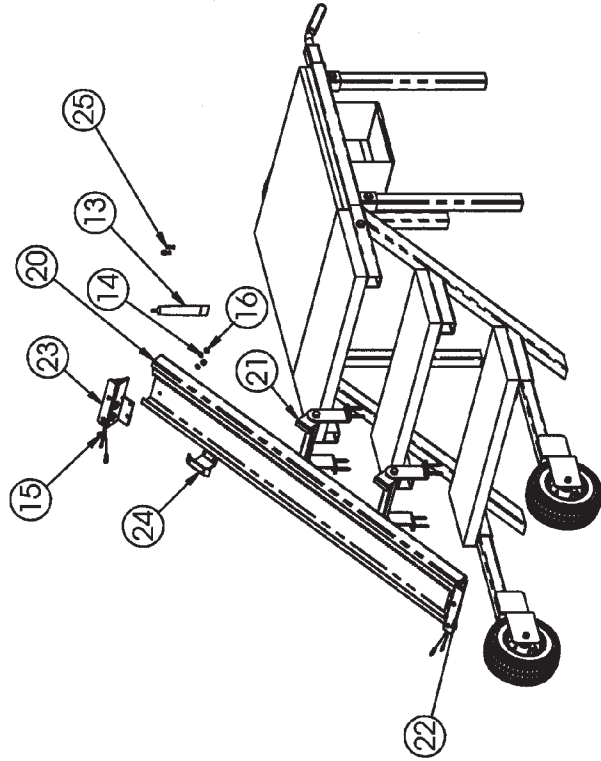

**FIVE YEAR MAJOR COMPONENTS WARRANTY
TWO YEAR LIMITED WARRANTY
for
Bruno Stairlifts**

Bruno Independent Living Aids, Inc. ("Bruno"), warrants to the original purchaser of a Bruno Stairlift that the Bruno Stairlift is free from defects in material and workmanship for a period of two years from date of purchase. In addition, Bruno warrants that the motor, gear box and rail (the "Major Components") will be free from defects in materials and workmanship for a period of five years from the date of purchase.

The exclusive remedy for a defect in a Bruno Stairlift shall be the repair or replacement, at the option of Bruno, of the defective part or component. After the first 30 days of this warranty, only parts and components are covered. This warranty does not cover labor and other services after the initial 30 days. If repair or replacement of a Bruno Stairlift is not commercially practical or cannot be timely made, Bruno may elect to refund the purchase price of the Bruno Stairlift instead of repairing or replacing the Bruno Stairlift.

IN NO EVENT SHALL BRUNO BE RESPONSIBLE FOR INDIRECT, INCIDENTAL OR CONSEQUENTIAL DAMAGES, WHETHER SUCH DAMAGES ARISE FROM CLAIMS BASED ON CONTRACT, WARRANTY, TORT (INCLUDING NEGLIGENCE), STRICT LIABILITY OR PRODUCT LIABILITY. Some states do not allow the exclusion or limitation of incidental or consequential damages, so the above limitation or exclusion may not apply to you.

ALL IMPLIED WARRANTIES, INCLUDING ANY WARRANTY OF MERCHANTABILITY OR FITNESS FOR A PARTICULAR PURPOSE, ARE LIMITED IN THEIR DURATION TO THE LENGTH OF THE WARRANTY STATED ABOVE FOR THE AFFECTED COMPONENT. Some states do not allow limitations on how long an implied warranty lasts so the above limitation may not apply to you.

To obtain warranty service, you must follow these procedures:

1. Obtain return authorization by calling your local Bruno dealer or Bruno at 1-800-882-8768;
2. Return the Bruno Stairlift, freight prepaid, to the address provided by your Bruno dealer or Bruno with proof of purchase indicating the date purchased.

Bruno will pay for shipping back to the purchaser within the continental United States and Canada if a defect in material or workmanship is discovered. Return freight and repair charges will be the responsibility of the purchaser if the problem is not covered by warranty.

This warranty does not cover damage or failure caused by misuse, abuse, accidents, physical damage, modifications not made by Bruno, damage in shipment, or repairs undertaken by anyone other than Bruno factory employees or authorized distributors. The "original purchaser" of a Bruno Stairlift that is leased or rented shall be the person or entity acting as the lessee or rental provider.

This warranty gives you specific legal rights, and you may also have other rights which vary from state to state. Bruno specifically does not authorize any person to extend the time or scope of this warranty.

For further information regarding this limited warranty, please contact Bruno by calling 1-800-882-8768 or writing to Bruno at the following address:

Bruno Independent Living Aids, Inc.
Attention: Service Department
1780 Executive Drive, Post Office Box 84
Oconomowoc, WI 53066 USA