



BRUNO®

INDEPENDENT LIVING AIDS

ISO 9001 CERTIFIED

SRE-1550 ELECTRA-RIDE™ II STAIRWAY ELEVATOR

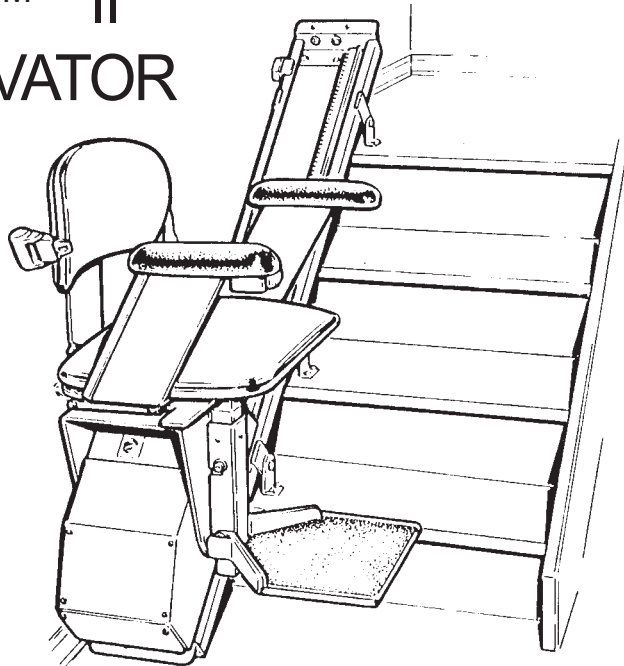

INSTALLATION MANUAL

www.bruno.com

1780 EXECUTIVE DR., P.O., BOX 84, OCONOMOWOC, WI 53066 USA

TEL.: (262) 567-4990 FAX: (262) 953-5501

Toll free number valid throughout the U.S. and Canada

Bruno invites your calls at:

1-800-882-8183

Technical Service email: service@bruno.com

Technical Service fax: 262-953-5503

DEALER:

**MAN-1550-1 UL
REVISED 06-18-2004**

IMPORTANT NOTES

The warranty for the Electra-Ride™ II
Stairway Elevator is
rendered null and void
if the unit is installed by
anyone other than an authorized Bruno dealer.

This stairway elevator is intended
for indoor use only
in a heated, enclosed location
above 35° F (2° C).

Electra-Ride™ is a trademark of Bruno Independent Living Aids, Inc.® . The Electra-Ride™ II, #5,230,405 is covered by one or more U.S. Patents and/or U.S. Patents Pending.

TABLE OF CONTENTS

IMPORTANT NOTES	2
REGULATORY INFORMATION	4
SPECIFICATIONS	5
INTRODUCTION	7
CARTON CONTENTS	8
OVERVIEW	9-10
INSTALLATION	11-46
Tools Necessary for Installation.....	11
Bumper Bracket Installation.....	12
Fitting the Rail.....	12
Application Guide.....	13-14
Cutting the Rail.....	15
Rail Joint Assembly.....	16
Positioning Foot Clamp Assemblies.....	17-18
Mount the Carriage on the Upper Rail.....	19
Adjust the Carriage Angle.....	19
Seat, Footrest and Arm Assemblies.....	20-23
Final Limit Switch and Ramp Actuation.....	24-25
Trial Run.....	26
Call/Send Transmitter/IR/Residential.....	27-31
Circuit Board Diagnostics-Residential.....	32-33
Conversion to Right-Hand Installation-Residential.....	34
Call/Send Transmitter/RF/Commercial.....	35
Circuit Board Diagnostics-Commercial.....	36-37
Conversion to Right-Hand Installation-Commercial.....	38
Testing the Call/Send Transmitters.....	39
Upper Bumper Bracket.....	40
Lubrication.....	40
Charger Mounting and Leads.....	41-42
Speed Adjustment.....	44
Mounting the Call/Send Antenna (Commercial Units).....	45
Overspeed.....	46
ELECTRICAL	47-48
Circuit Breaker.....	47
Fuse.....	47-48
Battery Charger LED's And Fuse.....	48
LONG-TERM STORAGE	49
YEARLY MAINTENANCE OPERATIONS	50
TROUBLESHOOTING	51-52
HARDWARE	53-57
WIRING SCHEMATICS	58-59
EXPLODED VIEW AND BILL OF MATERIALS	60-75
LIMITED WARRANTY	76

REGULATORY INFORMATION

FCC REGULATIONS

This equipment has been tested and found to comply with the limits for a Class B digital device, pursuant to Part 15 of the FCC rules. These limits are designed to provide reasonable protection against harmful interference in a residential installation. This equipment generates, uses, and can radiate radio frequency energy, and if not installed and used in accordance with the instructions, may cause harmful interference to radio communications. However, there is no guarantee that interference will not occur in a particular installation. If this equipment does cause harmful interference to radio or television reception, which can be determined by turning the equipment off and on, the user is encouraged to try to correct the interference by one or more of the of the following measures:

- Reorient or relocate receiving antenna.
- Increase separation between equipment and receiver.
- Consult your dealer or an experienced radio/TV technician.



Underwriters Laboratories, Inc. Regulations:

Installation of this lift is intended to be conducted in Accordance with ANSI ASME A17.5; A17.1, Part XX (Commercial) or Part XXI (Residential); and the National Electric Code NFPA 70.

SPECIFICATIONS

SRE-1550 ELECTRA-RIDE™ II

Weight Capacity:	350 lbs. (159 kg)
Variable Speed:	0 to 38 feet per minute (0 to 12 m/mn)
Power Source :	two (2) 12-volt sealed, maintenance-free batteries with 24-volt continuous-duty charger
Motor:	24 VDC, 2-pole, 1.02 hp
Drive:	self-locking gearbox, rack and pinion drive
Control:	constant pressure (armrest and two remotes)
Brake:	self-locking worm gear
Maximum Incline:	45 degrees
Rail:	steel channel with integral drive gear rack
Seat Swivel:	0, 45, and 90 degrees, both directions, at top and at bottom of rail
Power Supply:	24 VDC battery charger powered by 120V wall outlet

This page intentionally left blank.

INTRODUCTION

Thank you for purchasing an **SRE-1550 Electra-Ride™ II** Stairway Elevator. Be sure to check carton contents for shipping damage as soon as they are received. Also, check the carton contents against the packing list **before** leaving the shop to install product on site. Report any discrepancies to Bruno Independent Living Aids immediately.

Reading through the installation manual before installing this unit will enable you to install the elevator more quickly and will help you avoid the frustration of getting to the job site only to discover that you are missing a critical tool or piece of equipment.

**NOTE:
MATERIAL DATA SAFETY SHEET(S) ON
MATERIALS USED ON THIS UNIT CAN BE
REQUESTED THROUGH OUR TECHNICAL SERVICE
DEPARTMENT**

This unit is covered by one or more US Patents and/or has U.S. Patents Pending.

CARTON CONTENTS

The **ELECTRA-RIDE™ II** is shipped in 5 cartons. Check the contents of the cartons to be sure you have all of the components before beginning an installation.

CHECK CARTON CONTENTS FOR SHIPPING DAMAGE IMMEDIATELY UPON RECEIPT

Check the carton contents for shipping damage upon receipt. Damage claims must be filed by the **dealer**, not the manufacturer. Bruno Independent Living Aids cannot be responsible for shipping damage.

CARTON 1

- [] 1 COMPLETE CARRIAGE ASSEMBLY

CARTON 2

- [] 1 Tube WHITE LITHIUM GREASE (16' RAIL)
- [] 1 FINAL LIMIT SWITCH RAMP ASSEMBLY
- [] 1 BATTERY CHARGER
- [] 2 BUMPER ASSEMBLIES

SRE-K-1553 BUMPER ASSEMBLY PARTS KIT

- [] 4 M8 EXT. TOOTH WASHER
- [] 4 M8 X 1.25 X 20mm LG. HEX HD. CAP SCREW
- [] 4 M8 X 1.25 METRIC HEX NUT (PLATED)

- [] 4 VELCRO STRIPS (2.5" EA.)
- [] 10 11" LG WIRE TIES
- [] 32 SHEET METAL SCREWS (M6.3 X 50 MM) (16' RAIL); 40 FOR (20' RAIL)
- [] CLAMP SETS:
 - 9 (16' RAIL) • 11 (20' RAIL) • 13 (24' RAIL)
 - TBD** (CUSTOM RAIL)
- **DEPENDS UPON RAIL LENGTH
- [] UPON REQUEST CLAMPS, ADJUSTABLE, 9 LBS. EA.

***MSDS (Material Safety Data Sheet) available from Bruno upon request. Contact Service Department**

SRE-K-1501 ELECTRICAL PARTS KIT

- [] 1 CHARGER HOOKUP WIRE HARNESS
- [] 1 FUSE (MDL 3.5A TIME-DELAY)

CARTON 3

- [] 1 SEAT ASSEMBLY
- [] 1 FOOTREST ASSEMBLY
- [] 1 ANTENNA
- [] 2 CALL/SEND TRANSMITTERS
- [] 2 MOUNTING PLATES, CALL/SEND TRANSMITTERS

CALL/SEND HARDWARE KIT

- [] 1 SRE-K-2701 RESIDENTIAL
- OR---
- [] 1 SRE-K-0055A COMMERCIAL CALL/SEND KIT

*****NOTE: Rail sections must have matching numbers stamped on the sections.**

CARTON 4

- [] 1 EA. RAIL SECTION***

CARTON 5

- [] 1 EA. RAIL SECTION***
- [] 1 EA. JOINT PLATE

SRE-K-1502 HARDWARE KIT (JOINT PLATE)

- [] 8 EA. M6 X 16 FLAT HEAD SCREWS
- [] 8 EA. M6 HEX NUTS

OVERVIEW

Installation of the **ELECTRA-RIDE™ II Stairway Elevator** consists of the following:

- * Determine whether the elevator should be a left- or right-side installation. "Left" or "right" installation is determined by the side of the stairway on which the rail is installed (viewed from the bottom of the stairs). **THE GEAR RACK WILL BE TOWARD THE CENTER OF THE STAIRS.** Unless specified otherwise, Bruno Stairway Elevators are set up for left-side installation when shipped, but can easily be converted to right-side installation. Instructions for converting the unit for right-hand installation are included later in this manual.
- * Identify and locate lower rail section and bumper bracket assembly.
- * Assemble and tighten the rail joint. **CAUTION: RAILS CANNOT BE MIXED. CHECK ID NUMBERS STAMPED AT ENDS OF RAILS.**
- * Determine the correct length for the rail (using Steps 2 & 4 from the APPLICATION GUIDE), and cut the rail.
- * Install lower bumper assembly.
- * Position rail on left or right side of stairway using rail clamp assemblies.
- * Manually mount the carriage on the upper rail.
- * Adjust the carriage angle by loosening the four *angle adjustment bolts*.
- * Install seat assembly and make electrical connections.
- * Secure the footrest.
- * When installing a **right-side ELECTRA-RIDE™ II**, follow instructions for **Reversing Operation**.
- * Remove one motor cover (right-side installation only). Reverse the motor leads and set the two switches to reverse the direction of the Elevator.
- * Perform a trial run of the **ELECTRA-RIDE™ II** to determine final location of rail.

OVERVIEW

OVERVIEW (CON'T.)

- * Determine the appropriate location for the remaining mounting clamps and brackets for attaching the rail to the stairs then loosely assemble the clamps and brackets to the Stairway Elevator Rail.
- * Adjust and tighten the rail clamps and mounting brackets.
- * Anchor the mounting brackets to the stairs.
- * Locate and drill holes for the top bumper bracket.
- * Install the top bumper bracket.
- * Determine where the charger will be positioned, and install rail wire lead accordingly.
- * Position battery charger at upper or lower landing.
- * Route wire to household outlet.
- * Mount remote call/send transmitters.
- * Test unit for proper operation.
- * Train customer in safe and convenient operation of the Stairway Elevator.

REMEMBER:

No installation is complete until the customer has been trained to use the Elevator smoothly and safely. After demonstrating correct operation, have the customer operate the Elevator several times while you are available to answer questions.

BE SURE THE CUSTOMER UNDERSTANDS ALL SAFETY ASPECTS OF USING THE ELEVATOR. Patience and thoroughness in this phase of the installation are often rewarded with repeat business and customer referrals.

Tools Necessary for Installation

NOTE:

**THE STANDARD
STAIRWAY ELEVATOR IS
SUITABLE FOR STAIRWAY
ANGLES UP TO
45 DEGREES.**

- Protractor level, builder's level
- Socket set, metric (10 mm through 22 mm)
- Ratchet, with 6" extension
- Combination wrench set, metric (22 mm through 36 mm)
- Phillips screwdrivers
- Slotted screwdrivers
- Allen wrenches, metric (4 mm minimum size)
- Electric drill with letter 'O' (.316") and 1/4" bit
- Hacksaw with 2 or 3 blades, or metal cutting bandsaw
- 20' tape measure
- Small rubber mallet
- C-clamp
- Flashlight
- 5/16" open-end wrench
- Needle nose pliers
- Scissors or knife
- Extension cord
- Double-sided foam tape
- File
- 12" adjustable wrench

**BE SURE YOU HAVE ALL NECESSARY
PARTS AND TOOLS BEFORE TRAVELING TO
INSTALLATION SITE.**

INSTALLATION

ASSEMBLY-Residential and Commercial Units

- [] Determine whether a left- or right-side installation is appropriate for the site. "Left" or "right" refers to the side of the stairway on which the rail is installed (as viewed from the bottom of the stairs). *Unless otherwise specified Bruno Stairway Elevators are shipped from the factory in the left-side configuration.* Conversion to right-side installation is easy (instructions included later in this manual).
- [] Identify and locate lower rail section appropriate to the installation (left or right).

BUMPER BRACKET INSTALLATION

- [] Assemble lower rail
- [] Install bumper bracket.

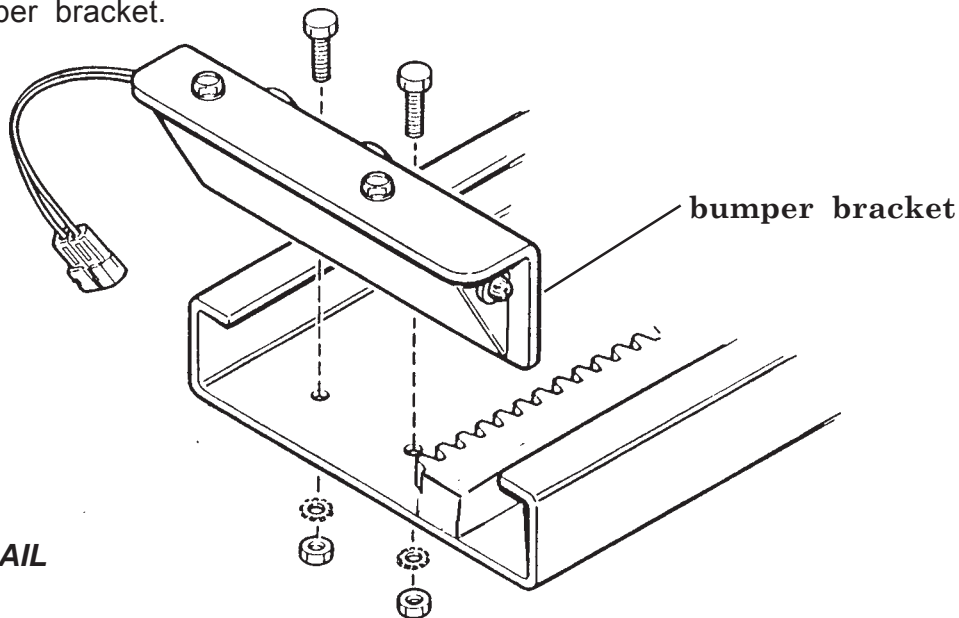

FITTING THE RAIL

- [] Determine the correct length for the rail by measuring along a straight line placed on the stairs. (SEE STEP 2 IN THE APPLICATION GUIDE) To that amount, add Measurement B (STEP 4 IN THE APPLICATION GUIDE). This process will allow you to custom fit the Elevator to your customer by determining the most comfortable seat-to-floor height within the space available at the top of the stairs.

NOTE: The rail must rest approximately 1/2" to 1" above nosing of the steps and extend from the lower floor to a point beyond the nosing of the top step (see Application Guide Step 4). In some cases where the bottom landing is made of material such as concrete, ceramic tile or slate, the last bracket on the landing may be omitted with a bracket added on the second step from the bottom and top of stairway.

REMINDER:

**THIS RAIL MUST BE INSTALLED 1/2" TO 1" ABOVE STAIR NOSING.
OTHERWISE, FOOTREST WILL HIT THE STEPS, CAUSING
INTERMITTENT OPERATION.**

INSTALLATION

APPLICATION GUIDE FOR BRUNO STRAIGHT STAIRWAY ELEVATOR SYSTEMS

DEALER: _____

PO# _____

CUSTOMER: _____

DATE: _____

STEP 1 DETERMINE THE STAIRCASE ANGLE

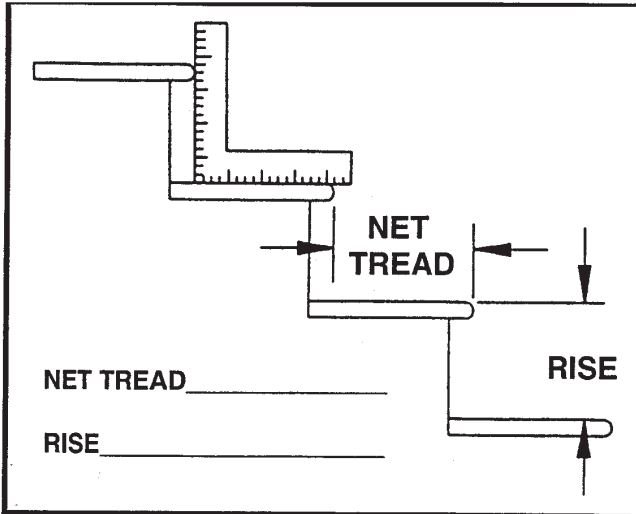

RISE	NET TREAD						
	12"	11"	10"	9"	8"	7"	6"
6"	27	29	31	34	37	41	45
7"	30	33	35	38	41	45	
8"	34	36	39	42	45		
9"	37	39	42	45			
10"	40	42	45				
11"	43	45					
12"	45						

NOTE: ANGLES ABOVE ARE ROUNDED TO THE NEXT DEGREE. FOR ANGLES ABOVE 45 DEGREES, CONSULT BRUNO FOR SPECIAL ORDER DETAILS.

STEP 2 DEFINE STAIRWAY DIMENSIONS AND DETAILS

STAIR TREAD MATERIAL _____

STAIRCASE WIDTH _____

LOWER LANDING MATERIAL _____

(32" Min. for Standard Unit)

UPPER LANDING MATERIAL _____

OBSTRUCTIONS _____

(i.e. Handrails, Moldings)

STEP 3 CHAIR AND RAIL DETAILS

SIDE OF STAIRWAY THE RAIL IS TO BE MOUNTED, LOOKING UP FROM BOTTOM:

LEFT: RIGHT:

CHAIR UPHOLSTERY:

TAN VINYL: TAN FABRIC:

RESIDENTIAL KEY PACKAGE:

COMMERCIAL PACKAGE:

PLEASE REFER TO "STEP 3" ON THE FOLLOWING PAGE FOR DETAILS.



Bruno Independent Living Aids, Inc.
1780 Executive Drive, P.O. Box 84,
Oconomowoc, WI 53066

1-800-882-8183 • (262) 567-4990

www.bruno.com

SALES DEPT. FAX (262) 953-5501

STEP 4 RAIL LENGTH

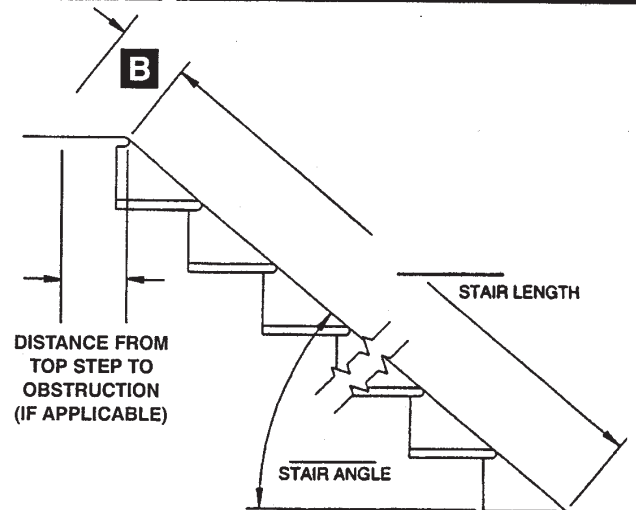

DETERMINE THE STAIR LENGTH: _____
ADD "B" TOP RAIL EXTENSION: _____

PLEASE REFER TO "STEP 4" ON THE FOLLOWING PAGE FOR DETAILS.

Overall Rail Length Required: _____

16' STOCK _____ 20' STOCK _____

24' STOCK _____ CUSTOM CUT RAIL _____

FORM ESLG D 0996-4 2/01-2 © Bruno Independent Living Aids, Inc. 2001

INSTALLATION

STEP 3 SRE-1550 ELECTRA-RIDE II™ APPLICATION DETAILS

TOP VIEW

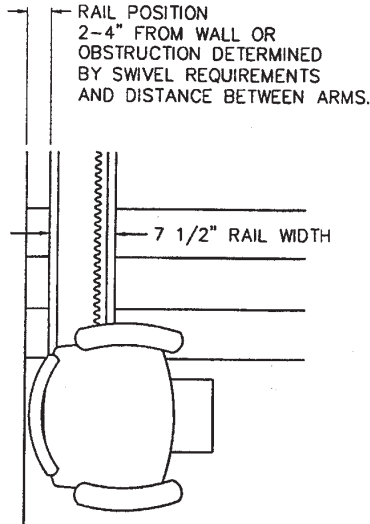

FRONT VIEWS

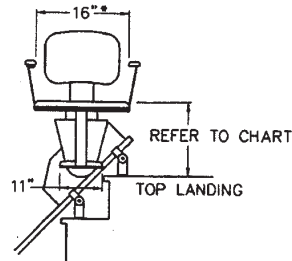

* DISTANCE BETWEEN ARMS IS ADJUSTABLE TO 20 INCHES.

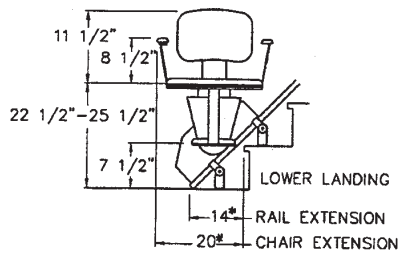

* LOWER LANDING EXTENSION DIMENSIONS ARE BASED ON 40 DEGREE RAIL SLOPE AND 8" 1ST RISER HEIGHT, DIMENSIONS WILL VARY BASED ON SLOPE AND RISER HEIGHT.

SIDE VIEWS

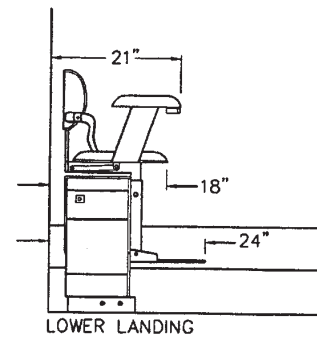
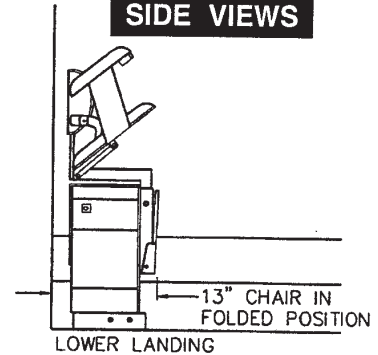

ALL DIMENSIONS SHOWN ARE BASED ON A WALL TO RAIL DIMENSION OF 3"

UPPER LEVEL ENTRY/EXIT SEAT HEIGHT IN INCHES

	17"	18"	19"	20"	21"	22"	23"	
35°	5.7	6.8	8.0	9.1	10.4	11.5	12.6	A
	6.9	8.3	9.7	11.1	12.6	14.0	15.4	B
36°	5.5	6.4	7.8	9.0	10.1	11.4	12.5	A
	6.8	8.2	9.6	11.1	12.5	14.0	15.4	B
37°	5.3	6.5	7.7	8.8	10.0	11.2	12.3	A
	6.6	8.1	9.6	11.0	12.5	14.0	15.4	B
38°	5.2	6.3	7.5	8.7	9.9	11.1	12.2	A
	6.5	8.0	9.5	11.0	12.5	14.0	15.4	B
39°	4.9	6.2	7.3	8.5	9.7	10.9	12.1	A
	6.3	7.9	9.4	10.9	12.4	14.0	15.5	B
40°	4.8	5.9	7.2	8.3	9.5	10.8	11.9	A
	6.2	7.7	9.3	10.8	12.4	14.0	15.5	B
41°	4.6	5.8	7.0	8.2	9.4	10.6	11.8	A
	6.0	7.6	9.2	10.8	12.4	14.0	15.6	B
42°	4.5	5.7	6.9	8.1	9.4	10.6	11.8	A
	5.9	7.5	9.1	10.7	12.4	14.0	15.6	B
43°	4.2	5.4	6.6	7.9	9.0	10.3	11.5	A
	5.7	7.4	9.0	10.7	12.3	14.0	15.7	B
44°	4.0	5.2	6.4	7.7	8.9	10.1	11.3	A
	5.5	7.2	8.9	10.6	12.3	14.0	15.7	B
45°	3.8	5.0	6.3	7.5	8.7	10.0	11.2	A
	5.3	7.1	8.8	10.6	12.3	14.1	15.8	B

DIMENSIONS ON CHART ARE WITH THE CHAIR IN THE LOWEST POSITION 22-1/2".

STEP 4

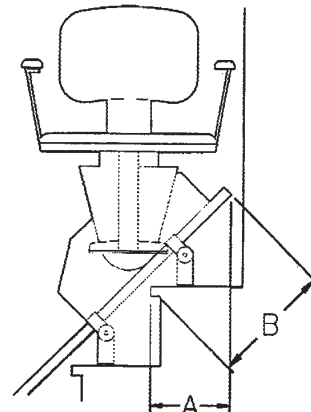

The chair extends approximately 3-4" beyond the rail at the upper landing.

ALTERNATE SEAT HEIGHT DIMENSIONS

- 23 1/2" @ Lower Level:
Reduce "B" Dimension 1.5" (3.8cm)
- 24 1/2" @ Lower Level:
Reduce "B" Dimension 3.0" (7.6cm)
- 25 1/2" @ Lower Level:
Reduce "B" Dimension 4.5" (11.4cm)

IF "A" is < 3" or "B" is > 12", then one or more adjustable clamp sets (SRE-00361) are required.

CUTTING THE RAIL-Residential and Commercial Units

IMPORTANT NOTE!

Under no circumstances should a rail section be cut shorter than 18" (46 cm).

There must be at least (2) clamps on a short rail section (1 at the rail joint and 1 at the rail end). Cutting a rail shorter than 18" (46 cm) would not allow enough room for the (2) necessary clamps.

Example:

After measuring the staircase, you determine you need 9 feet of rail. With your (2) 8-foot sections you decide to use (1) 8-foot section and cut the remaining (1) foot from the second 8-foot section.

Doing this could yield a rail piece with insufficient weld. Instead, Bruno recommends cutting at least one foot off one of the 8-foot sections (leaving 7 feet of rail) and then cutting 2 feet from the second 8-foot section. You will have a (1) 7-foot section and (1) 2-foot section, both of which are long enough to be properly mounted (2 clamps minimum per short rail).

NEVER CUT OFF THE JOINT END!

The M6 bolts securing the gear rack *must* remain intact.

Cut off the end with the pre-drilled charge contact mounting holes.

Then, using the provided template, redrill (2) holes on each end of the rail.

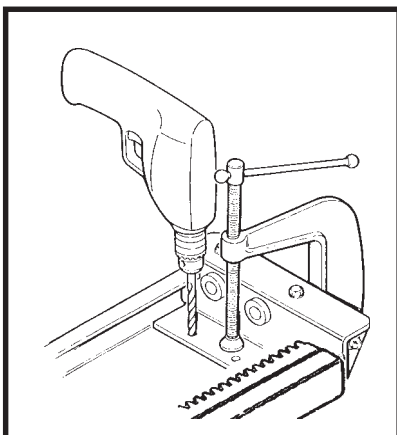

USE "O" SIZE DRILL BIT (8.03mm/.316")

1. Use a metal-cutting power saw or manual hacksaw to cut the rail to length. *Cut off the end of the rail to be located at the top of the stairway.*
2. Use a file or other appropriate tool to deburr the cut end of the rail. Soften any sharp edges which might abrade the insulation of the wiring to be routed to the bumper at the end of the rail.
3. Use a C-clamp to hold the upper bumper bracket in place in the cut end of the rail.
4. Use the holes in the bumper bracket as guides to drill mounting holes. Use an O-size (8.03 mm/.316") drill bit in the rail.

INSTALLATION

RAIL JOINT ASSEMBLY-Residential and Commercial Units

NOTE:
THE RAIL IS ALWAYS
INSTALLED WITH THE
GEAR RACK TOWARDS THE
CENTER OF THE STAIRS
AND GEAR TEETH FACING
WALL.

- [] Assemble the rail joint by attaching the bottom plate to the rail with the screws, lock washers and hex nuts provided with the unit. Install the bolts, internal-tooth washers and hex nuts through the joint blocks on both sides of the rail. Tighten all bolts securely and make sure screw heads are flush with the surface of the inside of the rail. **PLEASE REFER TO EXPLODED VIEWS AT BACK OF MANUAL.**

INSTALLATION SUGGESTION

Once two sections of rail are installed, and before installing the carriage, run a plumb line along the rail.
If the rail bows, insert shims or readjust clamps.

NOTE:
The chamfered edges of the holes
must face "up" toward the bottom
of the rail.

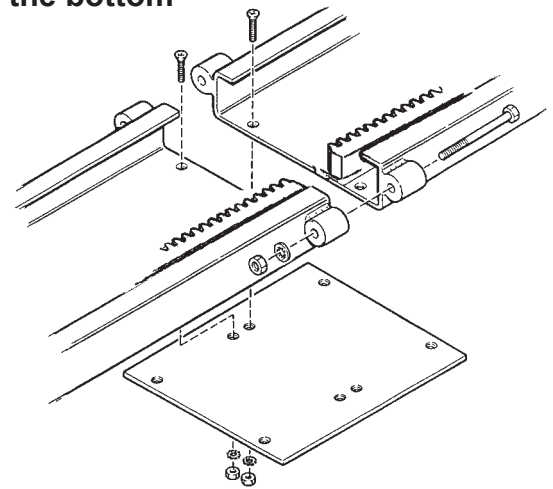

INSTALLATION

POSITIONING FOOT CLAMP ASSEMBLIES-Residential and Commercial Units

- [] Install rail mounting foot clamps in the placement pattern as shown below. **Be sure to leave a minimum space of 1-1/2" from the wall.**

- *bottom landing
- *first tread up from bottom landing
- *top landing
- *first tread down from top landing
- *closest tread above and below rail joint(s)
- *minimum of every third tread over the remainder of the staircase.

NOTE: IF TOP OR BOTTOM CLAMP IS OMITTED BECAUSE THE LANDING IS CEMENT OR CERAMIC TILE, OR IN THE EVENT THAT THE OWNER WISHES NOT TO DRILL HOLES IN THE LANDING, A SET OF CLAMPS SHOULD BE ADDED ON THE SECOND-TO- LAST STEP AND AT THE TOP OF STAIRWAY.

- [] For ease of installation, finger tighten all clamps to rail. *The clamp assembly should be positioned so the nut is closest to the wall.*
- [] Slide top and bottom clamps down until firmly seated on step. When installing on carpeted stairs, use a rubber mallet on the clamps to compress carpet and cushion before anchoring to steps.
- [] Securely install one screw near the wall on the top and bottom of foot of clamp assemblies. This will enable the installer to change the position of the rail if necessary and prevent drilling excess holes.

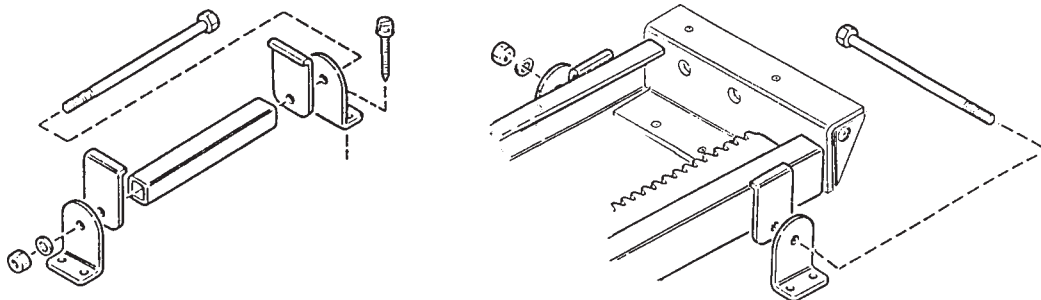

- [] Make sure to use the measurements indicated below as a guide for positioning the clamp assemblies.

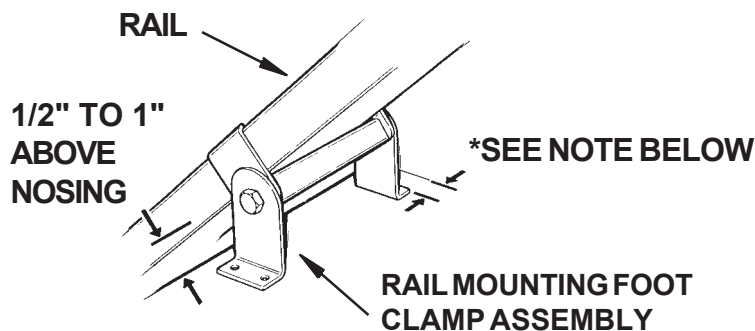

***INSTALL FOOT CLAMPS AT LEAST 1-1/2" FROM WALL. PROVIDE ADDITIONAL CLEARANCE IF SEAT NEEDS TO SWIVEL AGAINST WALL. BEFORE SECURING ALL CLAMPS, RUN CARRIAGE ASSEMBLY UP AND DOWN STAIRWAY TO CHECK SEAT CLEARANCE OVER THE ENTIRE TRAVEL LENGTH.**

INSTALLATION

Bruno ships the Stairway Elevator with fasteners appropriate for WOODEN STAIR TREADS ONLY. Other stair material may require different fasteners. Please contact Bruno Independent Living Aids, Inc. for information.

REMINDER:

**IF THREADED
FASTENER
EXTENDS
BELOW A
STAIR TREAD
THAT IS EX-
POSED, IT CAN
BE TRIMMED
FLUSH WITH
PLIERS.**

For installations on hardwood stairs, Bruno recommends drilling a pilot hole before inserting fasteners.

- [] Once the rail position is determined, place one screw in each bracket to hold rail in place while tightening to rail. This will prevent mounting feet from rotating while bolt is being tightened.)

- [] Tighten the rail bolt. Install the rest of the screws in bracket, then tighten securely.

INSTALLATION

MOUNTING CARRIAGE ON UPPER RAIL-RESIDENTIAL AND COMMERCIAL UNITS

- [] Turn toggle switch off. When facing the front of the unit, remove the left motor cover. Slide the carriage into the rail until the spur gear rests on the gear rack. Manually turn the motor pulley to fully engage the entire carriage inside the upper rail.

ADJUSTING THE CARRIAGE ANGLE-RESIDENTIAL AND COMMERCIAL UNITS

- [] Adjust the carriage angle by loosening the angle adjustment bolts. Level the angle adjustment aracket, using a standard builder's level or protractor level. When the angle adjustment bracket is level, securely tighten all four angle adjustment bolts*. **TORQUERATING=70 LB-FT**

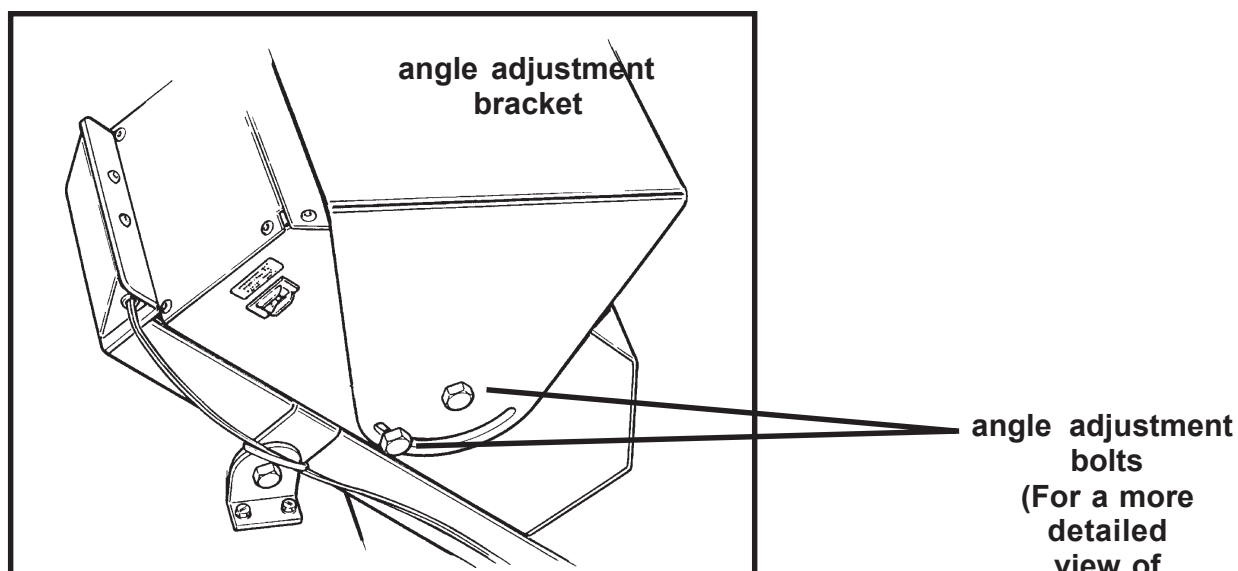

REMINDER:
Recheck with level after tightening adjustment bolts.

angle adjustment bolts
(For a more detailed view of safety lock washer inserted with lower bolt, see CARRIAGE ASSEMBLY DRAWING, SRE-00060, at the back of this manual.)

INSTALLATION

INSTALLING THE SEAT ASSEMBLY-RESIDENTIAL AND COMMERCIAL UNITS

- [] Feed the five-conductor lead through the hollow tube under the seat. Insert the seat frame post into the outer mounting tube. Determine the correct seat height, then insert the bolt in the corresponding hole. Make sure the head of the bolt protrudes 3/8" from the mounting tube. Fish excess wires into hole on front pivot bolt.

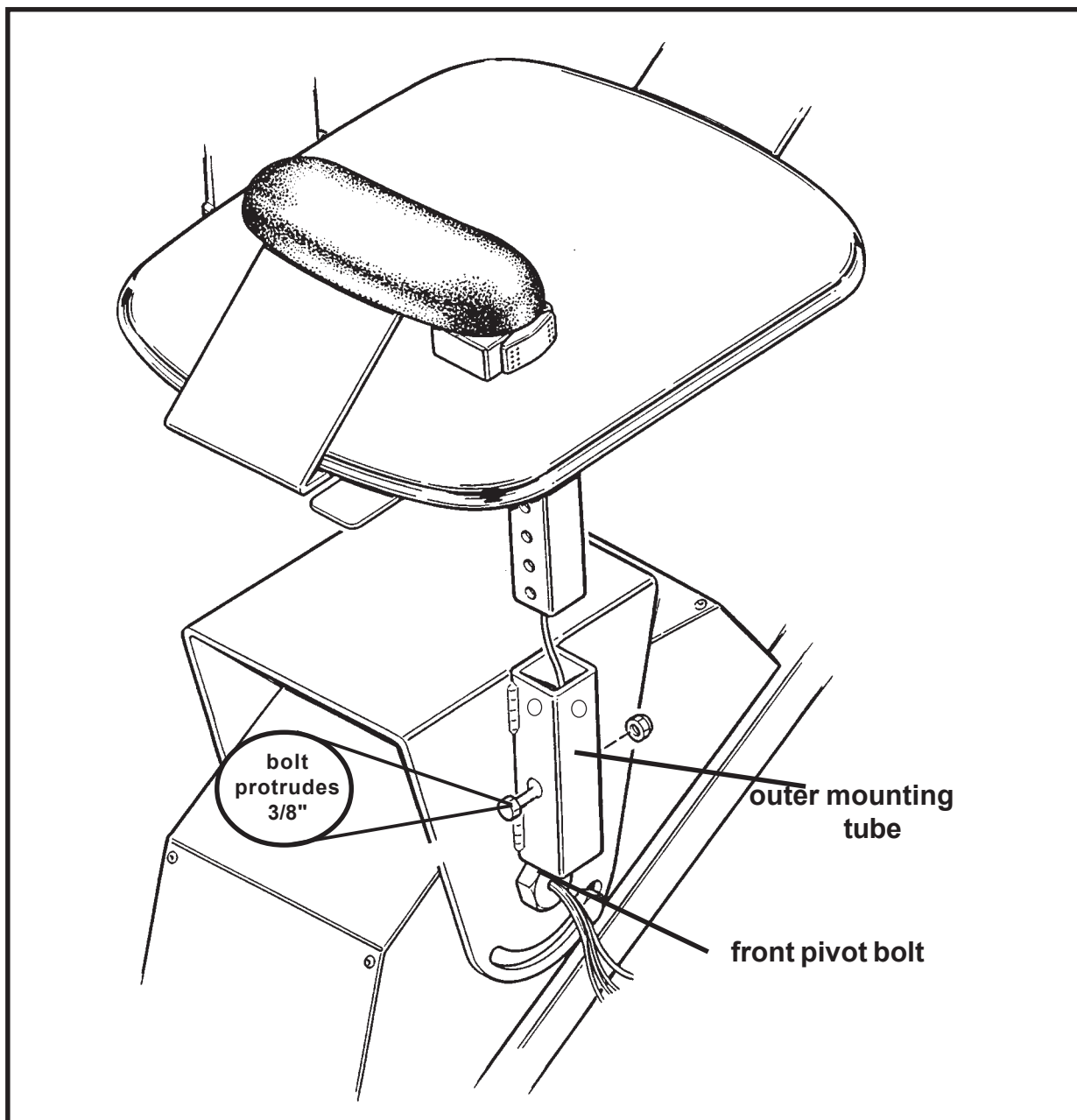

SEAT HEIGHT ADJUSTMENT-RESIDENTIAL AND COMMERCIAL UNITS

- [] Remove footrest assembly, then gently pull the extra wire from the hole in the pivot bolt. Remove the bolt in the outer mounting tube. Adjust seat height, replace bolt and secure. Reinsert extra wire in the pivot bolt. Replace the footrest assembly.

INSTALLATION

FOOTREST ASSEMBLY-RESIDENTIAL AND COMMERCIAL UNITS

- [] Connect the wires as shown in the illustration. Tuck the excess wires in the footrest hanger just above the footrest switch bracket, and below where the outer mounting tube would sit. While holding the wires in place bring the footrest close to the carriage, near the pivot bolt, tilt the footrest slightly while raising it up and over the bolt until it is engaged in the slot. Tighten the bolt, then the (2) set screws at the top of the footrest post (see illustration below) to completely secure the seat post.

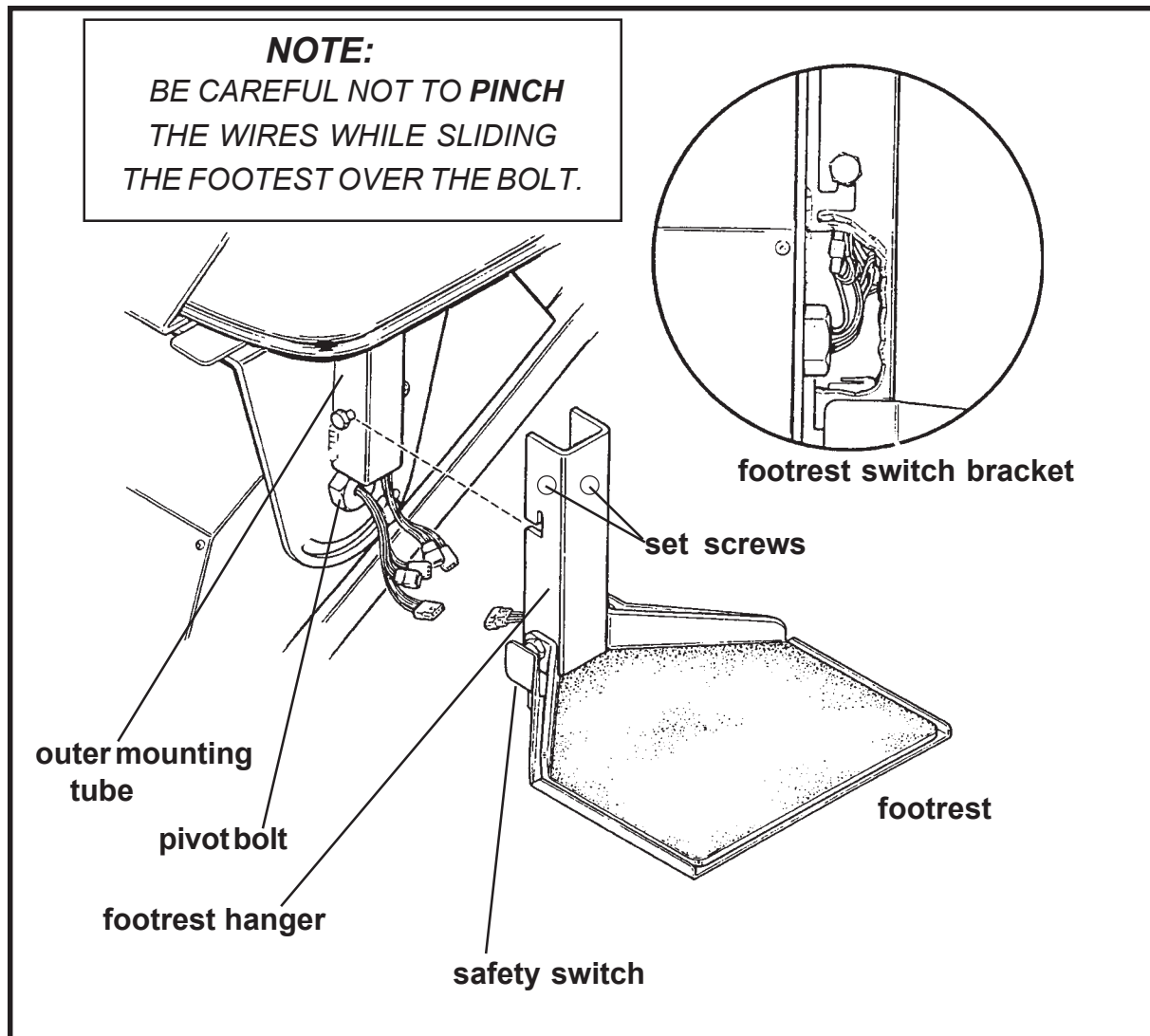

SAFETY SWITCH-RESIDENTIAL AND COMMERCIAL UNITS

- [] The footrest comes equipped with a safety switch which will stop the Elevator in the event that something becomes trapped between the footrest and a stair tread.
- [] Confirm correct operation of this feature by moving the sliding tray (BOTH SIDES) while operating the Elevator. The Elevator will stop if this feature is operating correctly.

INSTALLATION

SEAT SWIVEL AND ARM ROTATION-RESIDENTIAL AND COMMERCIAL UNITS

Fold the seat up when the Elevator is not in use. The seat latch will automatically keep the seat folded. To unfold the seat when ready to use the Elevator, the rider simply pushes down the seat, or pushes down on the arm rest. The swivel latch located directly under the seat allows the seat to rotate in 45-degree increments. To disengage the latch, lift up on either the right or left lever found at the front edge of the seat. Releasing the lever locks the seat in place.

Push the arm lock lever to rotate the arm up to 90 degrees for easy transfer. The arm then can be rotated back to its original position. The arm is locked in place automatically when the latch re-engages.

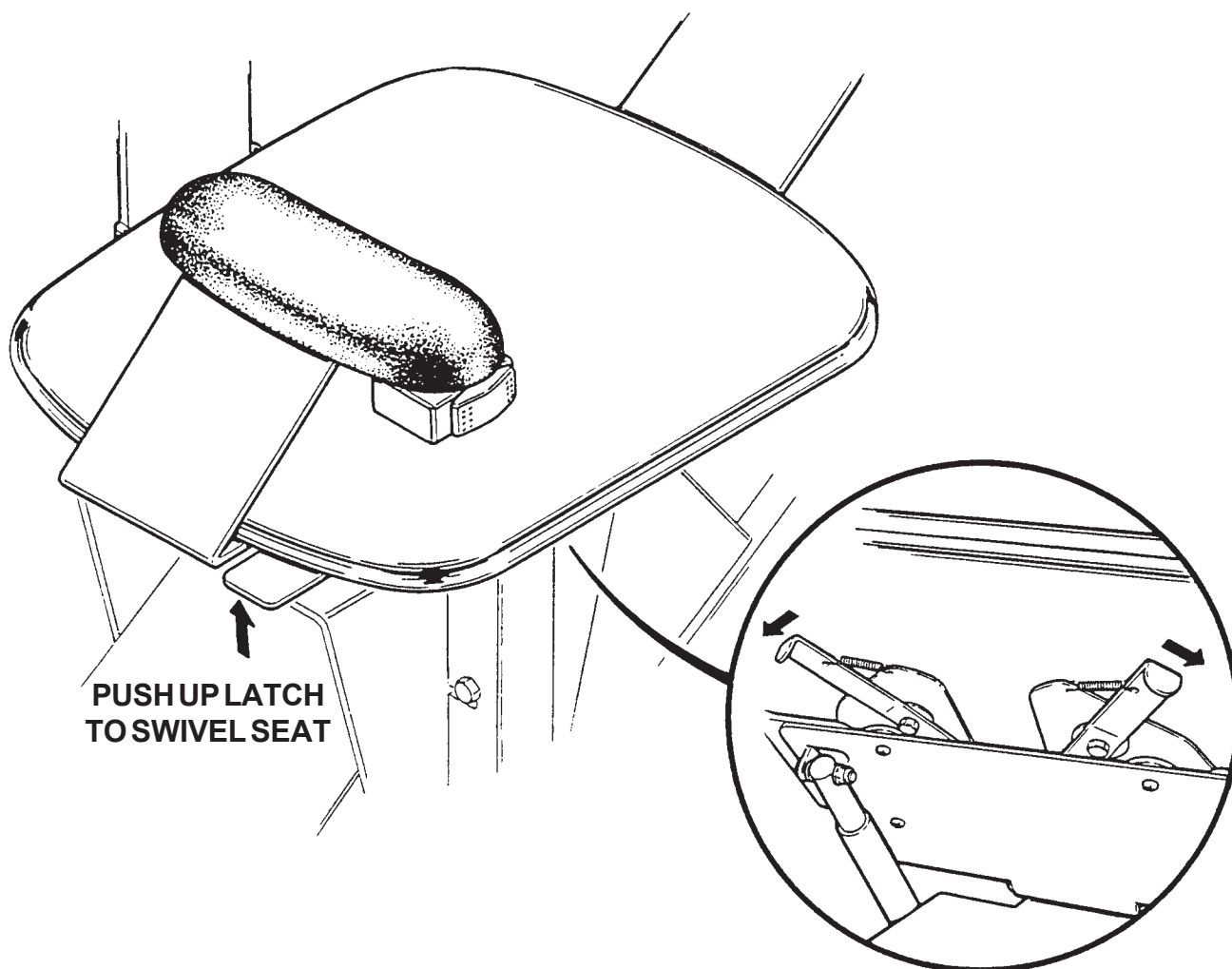

ARM ADJUSTMENT-RESIDENTIAL AND COMMERCIAL UNITS

The seat arms are set at the narrowest position. To adjust to a wider setting, loosen the Phillips head screws on the bottom of the seat (see illustration). Rotate arm out to desired position. Tighten the screws. Repeat process on other side.

NOTE:

IF EXTENDING THE ARMS TO MAXIMUM WIDTH, BE SURE TO ADJUST THE RAIL-TO-WALL DISTANCE TO COMPENSATE FOR THE INCREASED ANGLE OF ROTATION.

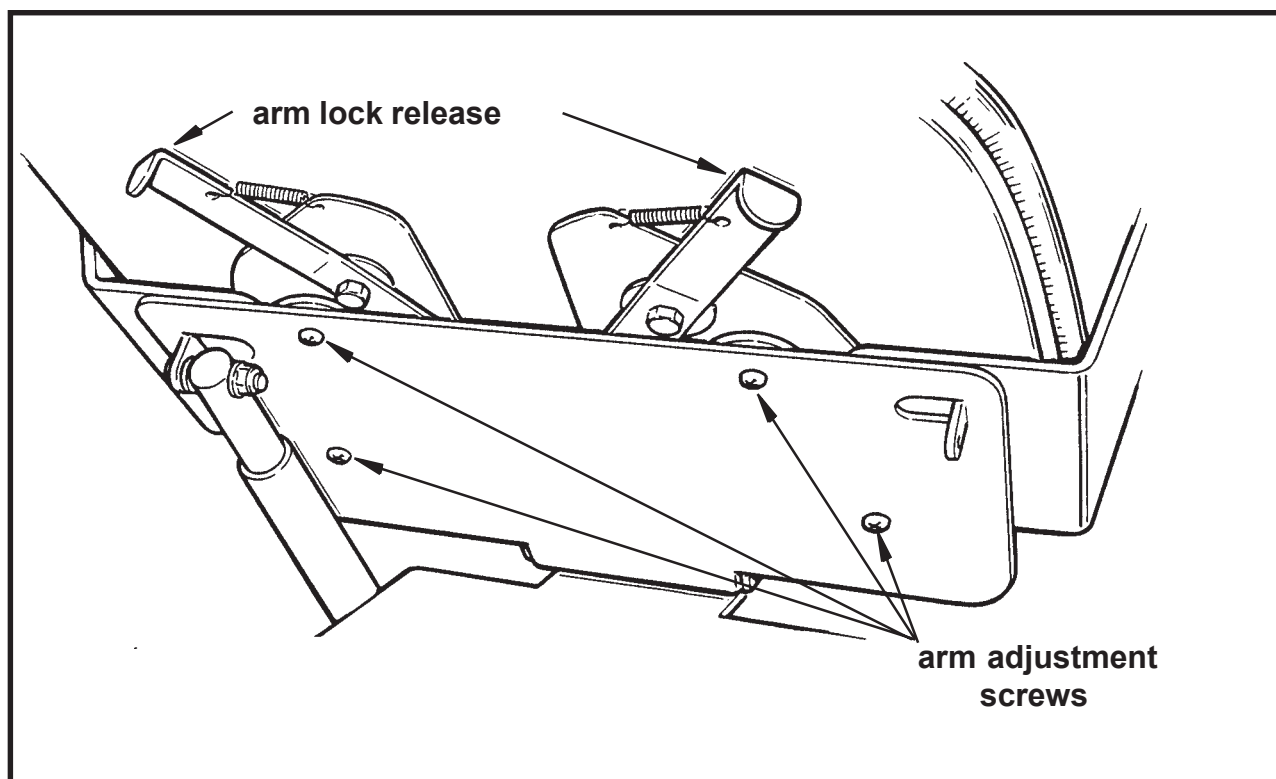

Arm Adjustment

INSTALLATION

FINAL LIMIT SWITCH AND ACTUATION RAMP-RESIDENTIAL AND COMMERCIAL UNITS

The final limit switch and actuation ramp assembly is a safety feature which enhances the stopping capability of the Elevator. The actuation ramp is to be mounted to the side of the rail, 1" from the top of the rail in a LEFT-HAND installation. In a RIGHT-HAND installation the mount the ramp 8" from the top end of the rail. Tighten M6 X 10 hex head screws on bottom of ramp.

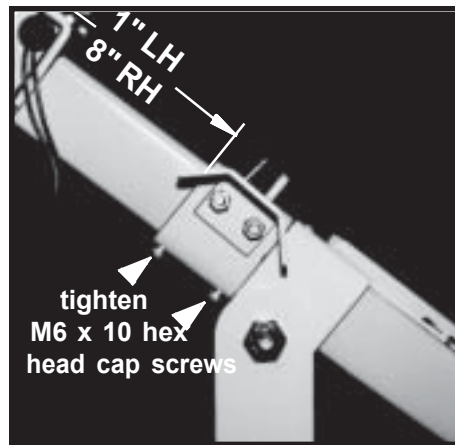

measure the distance from the end of the rail to the inside edge of the actuation ramp

The limit switches on the end of the carriages require adjustment:

- **Lengthen** the switch on the upper end of the carriage.

- *Shorten* the switch on the lower end of the carriage.

NOTE:

FAILURE TO ADJUST LIMIT SWITCHES WILL NOT ALLOW UNIT TO CHARGE.

- [] Remove seat
- [] Remove carriage from rail.
- [] To adjust limit switches remove covers and rotate angle adjustment bracket weldment, if necessary, to access the limit switches.
- [] Loosen limit switches using a 9/16" box wrench on the outside nut and a 5/8" open end wrench on the inside nut. It may also be necessary to use a pair of needle nose pliers. To access the limit switch on the motor side, it may be necessary to remove the charge contact assembly. Remove wire tie on the charge contact. Slide it out of the way, being careful to keep wires connected. Remove the outer nut on limit switch and slide limit switch out so that the inside nut can be adjusted. Tighten and reinstall parts. Replace covers and adjust the angle adjustment bracket. Replace unit on rail and perform a test to make sure unit will charge correctly.

CHARGE CONTACT



LIMIT SWITCH ADJUSTMENT



**MAKE SURE CONTACTS
ARE SECURELY TOUCHING
WHEN CARRIAGE STOPS
AGAINST RAIL END**

INSTALLATION

ELECTRA-RIDE TRIAL RUN

- [] With the seat in the central riding position, move the Elevator completely down and up the rail, while observing the elevator-to-wall clearance. A clearance of 1/2" to 1" is acceptable. Repeat the run with the seat in the folded position. If necessary, adjust the rail placement by sliding it closer to, or further from the wall.
- [] Verify proper operation of the following: speed, direction, final limit switch, footrest safety switch, seat swivel safety switch, and remote call/send transmitter.

**REMINDER:
MAKE SURE
SUFFICIENT CLEARANCE
EXISTS FOR CALL/SEND
ANTENNA OVER ENTIRE TRAVEL
OF RAIL.**

The carriage comes equipped with a safety switch panel. As the carriage approaches the end of the rail, the panel is depressed, which activates the switch, and stops the carriage.

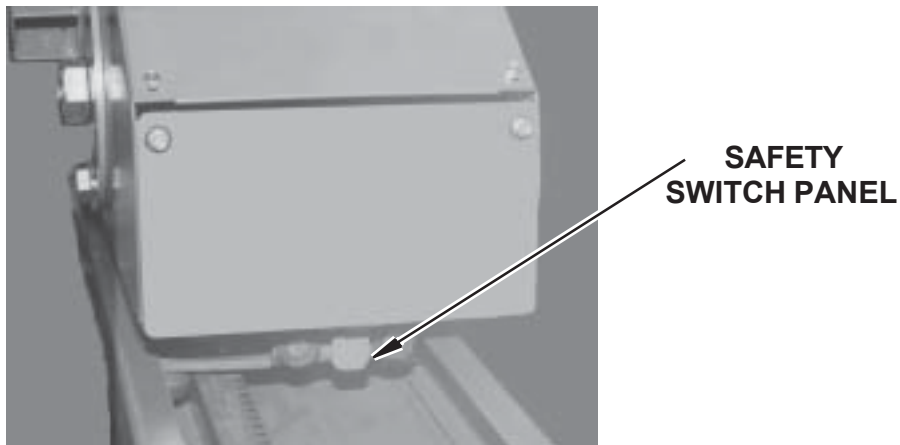

RESIDENTIAL

INFRARED CALL/SEND TRANSMITTER

The call/send system on the Bruno SRE-1550 is based on infrared (IR) controls, the same type of control used for televisions and stereos.

Like a television remote, the SRE-1550 hand-held transmitter may experience certain types of interference. Receivers are mounted on both sides of the SRE-1550 carriage to minimize interference.

Should interference occur, the unit will stop. This feature has been integrated into the SRE-1550 to ensure your safety.

The direct line between the transmitter to either of the (2) transmitters should be clear of obstacles for optimal operation. It may be necessary to reposition the transmitters so that they are aimed at the carriage.

To reduce the possibility of interference:

- While riding in the seat, ALWAYS operate the Elevator using the rocker switch on the armrest.

Operating the SRE-1550 with a transmitter while riding in the seat can lead to signal interference.

- DO NOT mount the transmitters behind an obstacle such as a rail post.
- DO NOT allow direct sunlight to shine on the receivers (blinding the receivers on the carriage).
- DO replace transmitter batteries regularly.

Depleted or nearly-depleted batteries alter the effective range of the transmitter.

- DO keep the transmitter and receiver lens free of dirt and debris.

Use a non-abrasive cleaner suitable for glass or acrylic surfaces.
Do not use polishes or cleaning products containing wax. These products will leave a film on the lens that will reduce the signal transmission range.

INSTALLATION

CALL/SEND TRANSMITTER-RESIDENTIAL



The 9V battery is inserted upside down in the IR transmitter when shipped from the Bruno factory. Prior to operating the SRE-1550, the installer must remove the battery and reinsert it so that the (+) and (-) poles are properly connected.

MOUNTING THE CALL/SEND TRANSMITTERS TO THE WALL

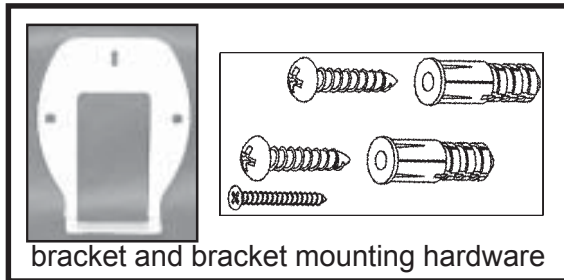

Remember to mount the transmitters in locations which are out of the reach of children, yet always visible to the operator from the stairway elevator.

- 1) On the back of the transmitter, loosen and remove the screw (a) securing the two halves of the transmitter.
- 2) Place the bracket (b) on the back of the transmitter. The base of the bracket will be flush with the bottom of the transmitter, with the base of the bracket pointing toward the front of the transmitter.
- 3) Insert the longest screw provided in the mounting hardware kit (see illustration above left) through the top hole in the bracket and through the corresponding hole in the back of the transmitter. Tighten, without overtightening to avoid damaging the transmitter back.
- 4) Turn the transmitter/bracket unit over so that the front of the transmitter is facing you.
- 5) Mount this unit to the wall using the two (2) #8 x .75" lg Phillips pan head sheet metal screws and the two (2) plastic ribbed anchors provided.
- 6) Run the unit up and down the stairs using the remote call/sent transmitter. Test both transmitters.
- 7) Repeat the test with the installer or installer's assistant sitting on the seat.



Step 1

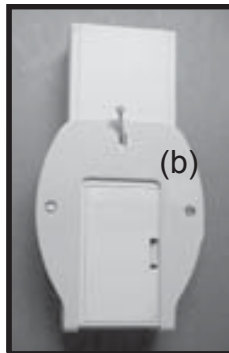

Steps
2 & 3



Step 4

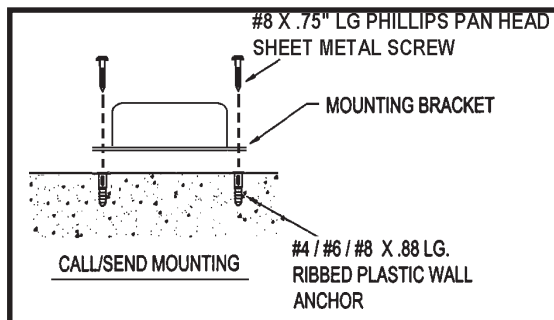

Step 5

NOTE:
**INSTALLATION OF THE
CALL/SEND UNIT MAY VARY BY
LOCAL CODE. PLEASE REFER
TO LOCAL CODES FOR
INSTALLATION GUIDELINES.**

LEARNING THE REMOTE INFRARED TRANSMITTER-RESIDENTIAL

(not necessary when installing unit for the first time)

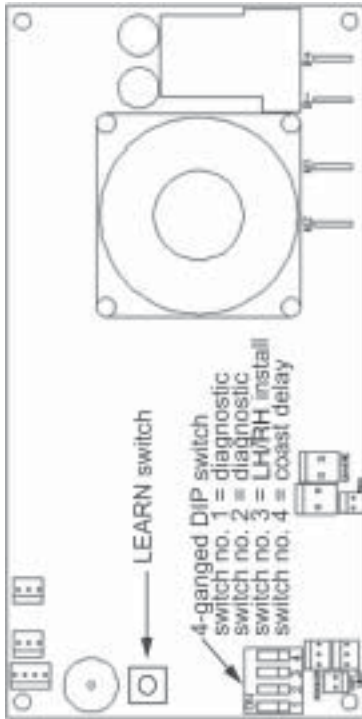

The operating channel of the two (2) infrared transmitters included with the SRE-1550 is pre-set at the Bruno factory.

Should it become necessary to re-learn the transmitters (for example, if there are multiple units in the same location, or in the event you have to replace transmitters) proceed as follows:

- 1) Turn off the circuit breaker.
- 2) Remove the carriage cover to expose the circuit board.
- 3) Locate the LEARN switch on the circuit board (see illustration to left).
- 4) On one of the IR TRANSMITTERS, remove the screw (a) securing the back to the transmitter. [If the transmitter is mounted to a wall, unscrew the (2) mounting bracket screws, turn the transmitter over and remove screw (a) securing the mounting bracket and the transmitter back.]
- 5) Remove the transmitter back and set aside with its screw.
- 6) On the *TRANSMITTER* circuit board, locate the switch (b) labelled "SW".
- 7) Change the configuration for switches 1 and 2.
Note: There are four possible configurations:
 - 1 up, 2 down (default manufacturer's setting)
 - 1 up, 2 up
 - 1 down, 2 up
 - 1 down, 2 down

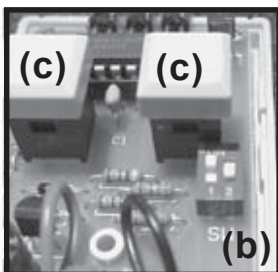

INSTALLATION

- 8) Once you have changed the switch positions:
 - Turn on the CARRIAGE circuit breaker.
 - Wait until you hear a BEEP.
 - **Press and hold** the LEARN switch on the *CARRIAGE* circuit board.
The red LED on the carriage circuit board will glow.
 - **AS YOU HOLD DOWN** the LEARN switch, press one of the TRANSMITTER pushbuttons.
 - When the red LED on the carriage circuit board goes out, release the LEARN switch and the transmitter pushbutton.
 - Depress the DOWN transmitter button (if the carriage is at the top of the rail), or the UP transmitter button (if the carriage is at the bottom of the rail). If the carriage moves, the new configuration has been accepted and the transmitter relearned.
- 9) Make sure both transmitters are set to the same switch configuration.
- 10) Reassemble and secure the transmitter back (remount on wall if applicable).
- 11) Reassemble and secure the carriage cover.

NOTE:
While using the remote call/send, you may experience some intermittent operation. This will not harm the unit. However, while using the rocker switch, operation should **NOT** be intermittent.

Transmitter Battery



The 9V battery is inserted upside down in the IR transmitter when shipped from the Bruno factory. Prior to operating the SRE-2000, the installer must remove the battery and reinsert it so that the (+) and (-) poles are properly connected.

To access the transmitter battery, open the door on the back of the transmitter as shown to the left.

WHEN THE INSTALLATION IS COMPLETE

Verify proper operation of the power supply, call/send transmitters, on/off switch, footrest, safety switches, and carriage limit switches.

Inform the customer of the location of the Owner's Manual. Encourage him/her to become familiar with its contents.

Train the customer to use the stairway elevator correctly and safely. Be sure to have him/her operate the unit while you are there to answer any questions and address any concerns.

INSTALLATION

CIRCUIT BOARD DIAGNOSTICS : RESIDENTIAL

The circuit board provided on the SRE-1550 is equipped with (4) diagnostic modes that continuously monitor the unit's operation. This choice of operational modes allows the SRE-1550 to respond to the requirements of a wide variety of installations.

NOTE : The SRE-1550 is shipped in the MULTI-USER/DIAGNOSTIC MODE.

MULTI-USER/DIAGNOSTIC MODE

Provides full range of Audio diagnostic notices:

- * **Circuit Board Power Up** : Chirp
- * **Safety Device Activated**: Chirp
- * **Elevator Stopped Off Charge Bumper**: 5 Beeps (4 short and 1 long)
Repeats every 3 minutes until the Elevator is returned to the bumper.
- * **Seat Safety Disengaged**: Chirp repeats every 3 seconds until seat safety switch is re-engaged.
- * **Battery Voltage Drop** : 5 Beeps (3 short and 2 long)
Repeats every 4 minutes until seat safety switch is disengaged, the battery voltage increases, or the switch is pressed.
- * **Battery Voltage Critical**: 5 Beeps (2 short and 3 long)
Repeats once a minute until the voltage exceeds 16V or the switch is pressed.
- * **Switch Active During Power Up**: 3 Beeps / Pause/5 Beeps (UP, DOWN, LEARN, REMOTE UP, REMOTE DOWN)Repeats beeps every 5 seconds until all switches are off.
- * **More Than One Switch Active**: 3 Beeps / Pause/X beeps (number of beeps indicates which switches are active)
Repeats every 30 seconds until all switches are off.
- * **Transmitter ID Memory Full**: 3 Beeps (1 short and 2 long)

SINGLE-USER MODE

Provides the same audio diagnostic notices as the Multi-User/Diagnostic Mode, except for the Seat Safety Disengaged notice.

QUIET MODE

In the QUIETmode, none of the Audible Warning Messages is active.

BATTERY WARNINGS ONLY MODE

Provides battery audio diagnostic only.

- * **Elevator Stopped Off Charge Bumper**: 5 Beeps (4 short and 1 long)
Repeats every 3 minutes until Elevator is returned to the bumper.
- * **Battery Voltage Drop** : 5 Beeps (3 short and 2 long)
Repeats once every 4 minutes until the seat safety switch is disengaged or the battery voltage increases.
- * **Battery Voltage Critical**: 5 Beeps (2 short and 3 long)
Repeats once a minute until voltage is above 16 V.

CIRCUIT BOARD DIAGNOSTICS : *RESIDENTIAL*



NOTICE:

Before touching anything inside the carriage assembly, ground yourself by touching an unpainted metal surface on the unit such as an exposed bolt, or one of the mounting screws on the electrical panel. While you work, periodically touch an unpainted metal surface to dissipate any static electricity that could harm internal components.

AUDIO REFERENCE

Chirp	.25 Seconds
Short Beep	.5 Seconds
Long Beep	1.5 Seconds
Pause	1 Second

CHANGING THE PCB DIAGNOSTIC MODE

- * Turn the Circuit Breaker on the carriage to `OFF'.
- * Remove Left Carriage Cover.
- * Unit is shipped in Multi-User Diagnostic Mode. Changes are made via the Number 1 and Number 2 positions on the 4-Ganged DIP Switch.

4 GANGED DIP SWITCH (S1)

DIAGNOSTIC MODE	DIP SW NO. 1	DIP SW NO. 2
Multi-User	OFF	OFF
Single-User	ON	OFF
Quiet	OFF	ON
Battery Warning Only	ON	ON

OTHER CIRCUIT BOARD FEATURES

Also located on the 4-ganged DIP Switch are Switch No. 3 (LH/RH installation) and Switch No. 4 (coast delay). Refer to the Conversion to Right-Hand Installation instructions for changing Switch No. 3. The coast delay option (Switch No. 4) has been provided in cases of interference which may cause intermittent operation. The normal setting is 600 mSec. of coast. Should the unit lose the remote call/send signal, this can be increased to 900 mSec. by moving Switch No. 4 to the `ON' position.

INSTALLATION

CONVERSION TO RIGHT-HAND INSTALLATION - *RESIDENTIAL UNIT*

As shipped from the factory, the Electra-Ride™ II is set up for left-side installation (as viewed from the bottom of the stairs).

To convert the unit for right-side installation, perform the following operations:

ELECTRICAL

1. Make sure the circuit breaker switch on the rear of the carriage is in the OFF position.
2. Remove the back carriage cover and the left side cover.
3. Set the No. 3 DIP Switch on the 4-ganged dip switch to the **ON** position.

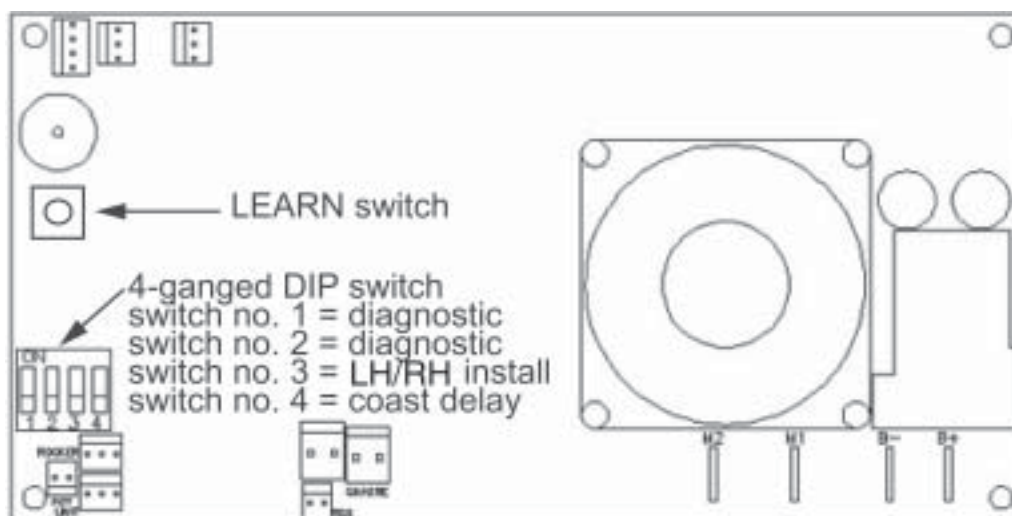

NOTE: It is imperative that the circuit breaker be turned OFF while changing from left-hand to right-hand installation. Otherwise, the board will not accept the change.

CHANGING CONTROLS FROM RIGHT TO LEFT ARMREST

1. Remove the switch housing weldment by removing the Torx head machine screw under the arm. The trim holding the harness on the backside of the arm slides off.
2. To disconnect the harness under the seat, remove the seat hinge nut.
3. Slide the harness cable guide off.
4. Reinstall the seat hinge nut.
5. Remove the 2 screws from the swivel switch cover, then remove the cover.
6. Unplug the switch harness, and remove the grommet.
7. Slide the grommet onto the other side of the swivel switch cover, and reconnect the harness.
8. Reassemble the cover using the 2 screws.
9. Remove the seat hinge nut, and install the harness guide on the opposite side.
10. Fasten the switch housing on the left arm. Slide the trim over the harness on the backside of the arm.

COMMERCIAL CALL/SEND TRANSMITTER

*Install the key-controlled call/send transmitters as shown below. The key switch should be approximately 48" from the floor. One transmitter should be installed at the top of the stairs, and one at the bottom.

The seat key switch and rocker switch are located under the right arm pad (on your right as you are sitting in the seat).

Please refer to the instructions "Changing Controls From Right to Left Armrest" if the unit will be installed on the right side of the stairway (as viewed from the bottom of the stairs).

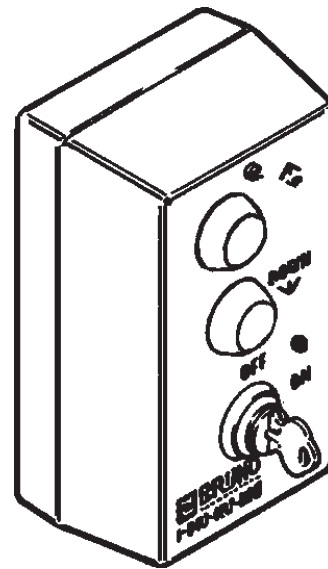

INSTALLING COMMERCIAL CALL/SEND TRANSMITTER

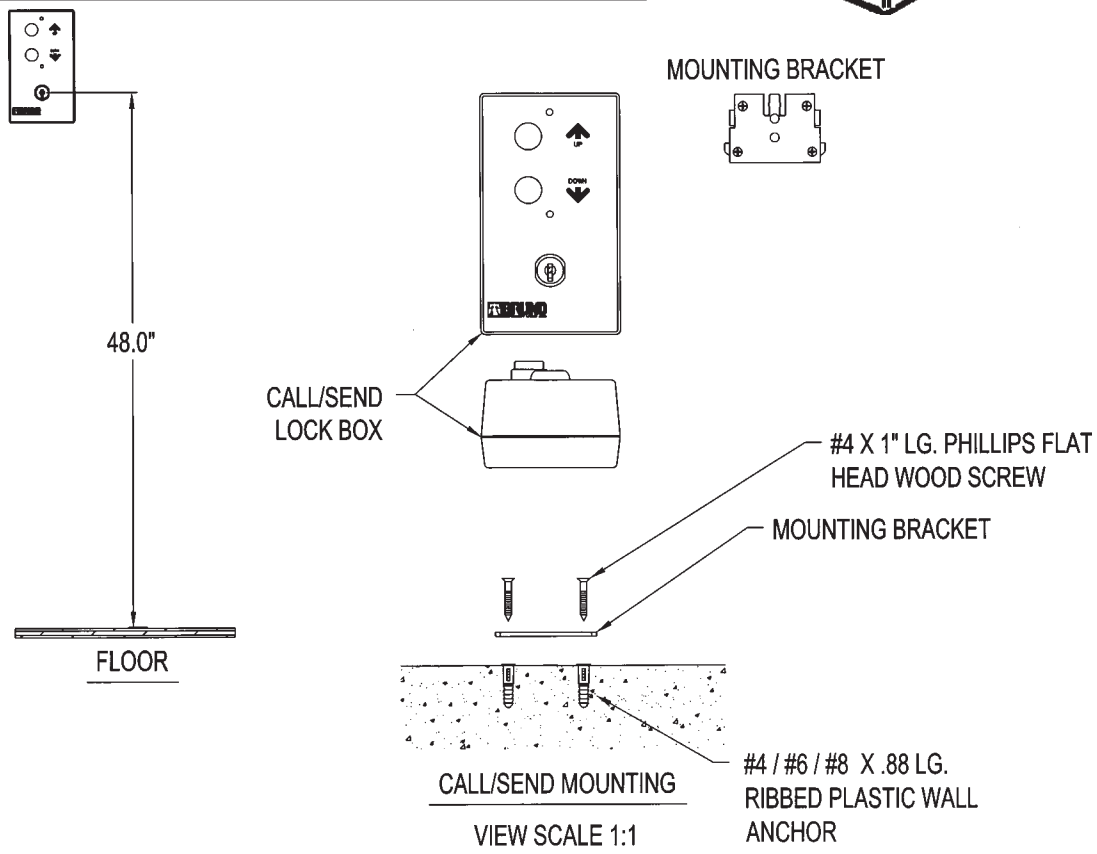

INSTALLATION

CIRCUIT BOARD DIAGNOSTICS : COMMERCIAL

The circuit board provided on the SRE-1550 is equipped with (4) diagnostic modes that continuously monitor the unit's operation. This choice of operational modes allows the SRE-1550 to respond to the requirements of a wide variety of installations.

NOTE : The SRE-1550 is shipped in the MULTI-USER/DIAGNOSTIC MODE.

MULTI-USER/DIAGNOSTIC MODE

Provides full range of Audio diagnostic notices:

- * **Circuit Board Power Up** : Chirp
- * **Safety Device Activated**: Chirp
- * **Elevator Stopped Off Charge Bumper**: 5 Beeps (4 short and 1 long)
Repeats every 3 minutes until the Elevator is returned to the bumper.
- * **Seat Safety Disengaged**: Chirp repeats every 3 seconds until seat safety switch is re-engaged.
- * **Battery Voltage Drop** : 5 Beeps (3 short and 2 long)
Repeats every 4 minutes until seat safety switch is disengaged, the battery voltage increases, or the switch is pressed.
- * **Battery Voltage Critical**: 5 Beeps (2 short and 3 long)
Repeats once a minute until the voltage exceeds 16V or the switch is pressed.
- * **Switch Active During Power Up**: 3 Beeps / Pause/3 Beeps (UP, DOWN, LEARN)
Repeats beeps every 5 seconds until all switches are off.
- * **More Than One Switch Active**: 3 Beeps / Pause/X beeps (number of beeps indicates which switches are active)
Repeats every 30 seconds until all switches are off.
- * **Transmitter ID Memory Full**: 3 Beeps (1 short and 2 long)

NOTE:
The Commercial SRE-1550
is shipped in
Multi-User/Diagnostic Mode.

SINGLE-USER MODE

Provides the same audio diagnostic notices as the Multi-User/Diagnostic Mode, except for the Seat Safety Disengaged notice.

QUIET MODE

In the QUIETmode, none of the Audible Warning Messages is active.

BATTERY WARNINGS ONLY MODE

Provides battery audio diagnostic only.

- * **Elevator Stopped Off Charge Bumper**: 5 Beeps (4 short and 1 long)
Repeats every 3 minutes until Elevator is returned to the bumper.
- * **Battery Voltage Drop** : 5 Beeps (3 short and 2 long)
Repeats once every 4 minutes until the seat safety switch is disengaged or the battery voltage increases.
- * **Battery Voltage Critical**: 5 Beeps (2 short and 3 long)
Repeats once a minute until voltage is above 16 V.

CIRCUIT BOARD DIAGNOSTICS COMMERCIAL UNIT



NOTICE:

Before touching anything inside the carriage assembly, ground yourself by touching an unpainted metal surface on the unit such as an exposed bolt, or one of the mounting screws on the electrical panel. While you work, periodically touch an unpainted metal surface to dissipate any static electricity that could harm internal components.

Chirp	.25 Seconds
Short Beep	.5 Seconds
Long Beep	1.5 Seconds
Pause	1 Second

CHANGING THE PCB DIAGNOSTIC MODE

- * Turn the Circuit Breaker on the carriage to `OFF`.
- * Remove Left carriage cover.
- * Turn the Power DIP Switch (SW3) to the `OFF` position.
- * Unit is shipped is Multi-User Diagnostic Mode. Changes are made on (S1) 4 Ganged DIP Switch - Number 3 and Number 4 Positions.

4 GANGED DIP SWITCH (SW1)

DIAGNOSTIC MODE	DIP SWITCH POSITION	
	#3	#4
Multi-User	OFF	OFF
Single-User	OFF	ON
Quiet	ON	OFF
Battery Warning Only	ON	ON

OTHER CIRCUIT BOARD FEATURES

Also located on S1 DIP Switch are switch #1 Installation and #2 Coast Delay. Refer to Reversing Operation instructions for changing Switch # 1. The coast delay option (Switch #2 on S1) has been provided in cases of interference which may cause intermittent operation. The normal setting is 600 mS seconds of coast, should the unit lose the remote call/send signal, this can be increased to 900mS seconds by moving switch # 2 on S1 to the `ON` position.

INSTALLATION

CONVERSION TO RIGHT-HAND INSTALLATION-COMMERCIAL UNIT

As shipped from the factory, the Elevator is set up for left-hand installation (as viewed from the bottom of the stairs.) Should the installation require a right-hand installation, perform the following operations:

- Turn the on / off circuit breaker on the rear of carriage to 'OFF'.
- Remove left carriage cover.
- Set the Installation DIP Switch (S2) to the 'RH' position.
- Set the No. 1 DIP Switch on the 4-Ganged Dip Switch (S1) to the 'OFF' position.
- Check that the power Switch (S3) is turned 'ON' .
- Unplug the motor leads and reverse the connections.
- Turn the circuit breaker switch to the "ON" position.
- Replace the carriage cover.

CIRCUITBOARD

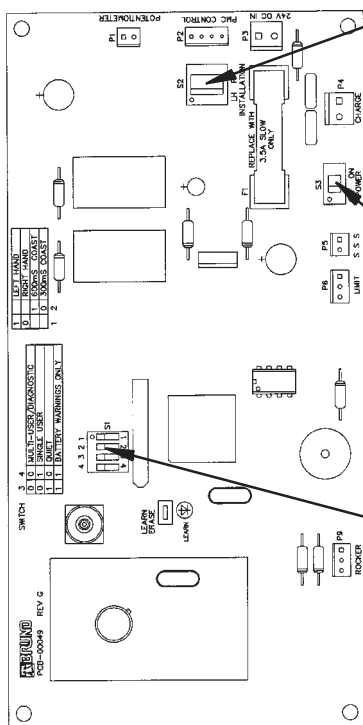

SET THE
INSTALLATION DIP
SWITCH (S2) FROM
'LH' TO 'RH'
POSITION

POWER DIP
SWITCH (S3)

SET NO. 1 SWITCH OF
(S1)
TO THE 'OFF'
POSITION

REVERSING CONNECTIONS

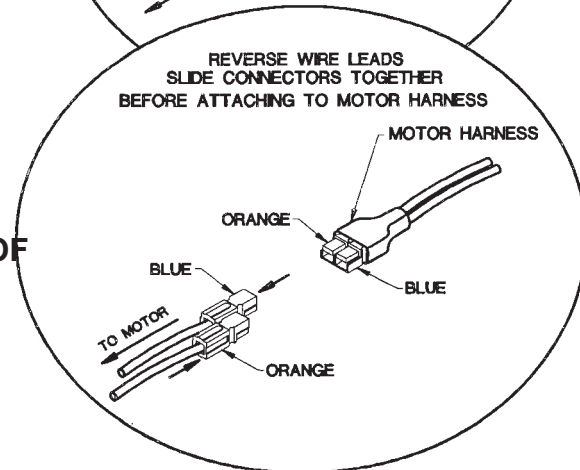
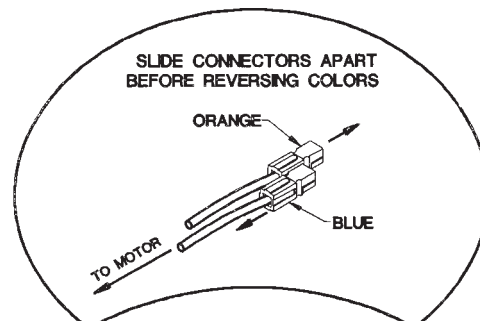

CHANGING CONTROLS FROM RIGHT TO LEFT ARMREST

1. Remove the switch housing weldment by removing the Torx head machine screw under the arm. The trim holding the harness on the backside of the arm slides off.
2. To disconnect the harness under the seat , remove the seat hinge nut.
3. Slide the harness cable guide off.
4. Reinstall the seat hinge nut.
5. Remove the 2 screws from the swivel switch cover, then remove the cover.
6. Unplug the switch harness, and remove the grommet.
7. Slide the grommet onto the other side of the swivel switch cover, and reconnect the harness.
8. Reassemble the cover using the 2 screws.
9. Remove the seat hinge nut, and install the harness guide on the opposite side.
10. Fasten the switch housing on the left arm. Slide the trim over the harness on the backside of the arm.

Testing the Call/Send Transmitters

A slight delay will occur between the time the rocker switch is depressed and the initiation of carriage movement. This is normal and is a function of the *soft start* feature of the controller.

- ◆ Run the unit up and down the stairs using the rocker switch on the carriage. The unit should operate in such a way that the arrow depressed on the rocker switch corresponds to the desired direction of travel.

The unit should travel noticeably faster going up than down.

- ◆ Run the unit up and down the stairs using the remote call/send transmitters. Test both transmitters.
- ◆ Push the seat into the stored position and run the unit up and down the stairs with the remote call/send transmitter.
- ◆ With the seat in the central riding position, move the Elevator completely down and up the rail, while observing the elevator-to-wall clearance. A clearance of 1/2" to 1" is acceptable. Repeat the run with the seat in the folded position. If necessary, adjust the rail placement by sliding it closer to, or further from the wall.
- ◆ Verify proper operation of the following: speed, direction, final limit switch, footrest safety switch, seat swivel safety switch, and remote call/send transmitter.

Train the customer to use the stairway elevator correctly and safely. Be sure to have the customer operate the unit while you are there to answer any questions or concerns. Remind the customer to always use the seat belt.

INSTALLATION

UPPER BUMPER BRACKET

- [] Install the upper bumper bracket to rail.

Installation Note:

Before tightening the brackets, check to make sure that the bumper wires are not trapped under the bumper bracket at the lower landing.

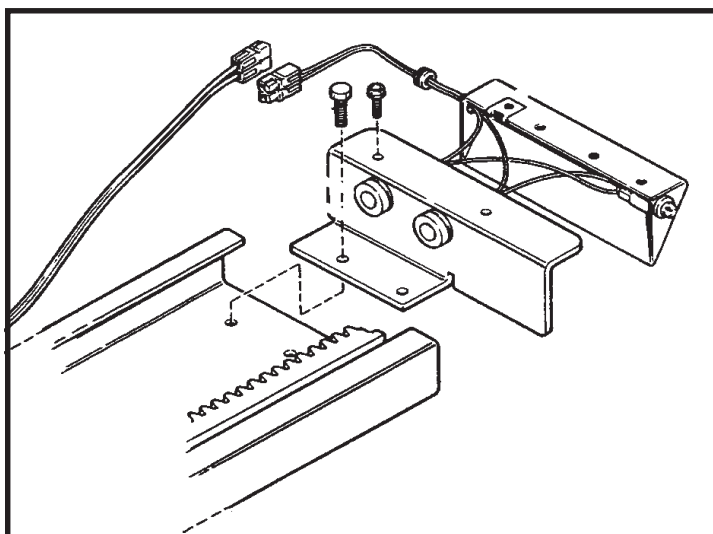

PRIOR TO LUBRICATION, run the carriage up and down the rail five to six (5-6) times. This will clean the paint chips out of the gear rack. Vacuum or brush the gear rack and rail to remove any paint chips loosened during this operation. Once the gear rack and rail are clean and free of paint debris, proceed with lubrication.

LUBRICATION

- [] Apply a thin coating of white lithium grease to the gear rack *TEETH ONLY* (see illustration below).

Apply a light coating of white lithium grease to the gear rack teeth only.

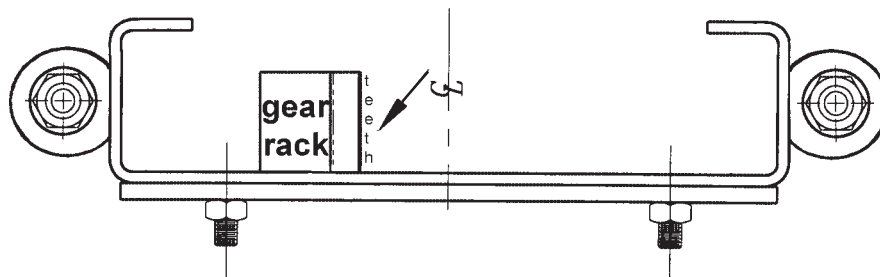

These instructions apply to carriages with *nylon wheels*. If you are lubricating a carriage with **steel wheels**, apply the grease to the rail *and* the gear rack teeth.

1 TUBE PER 16-FOOT UNIT

INSTALLATION

Position the Charger in a suitable permanent location near the end of the rail. Be sure that it will not pose a tripping hazard. Connect the power cord to the nearest wall or floor outlet. Bundle together the loose wires. Secure the charger mounting bracket with (2) #8 x 0.75" lg. Phillips pan head sheet metal screws.



CHARGER MOUNTING BRACKET

CHARGER LEAD CONNECTIONS

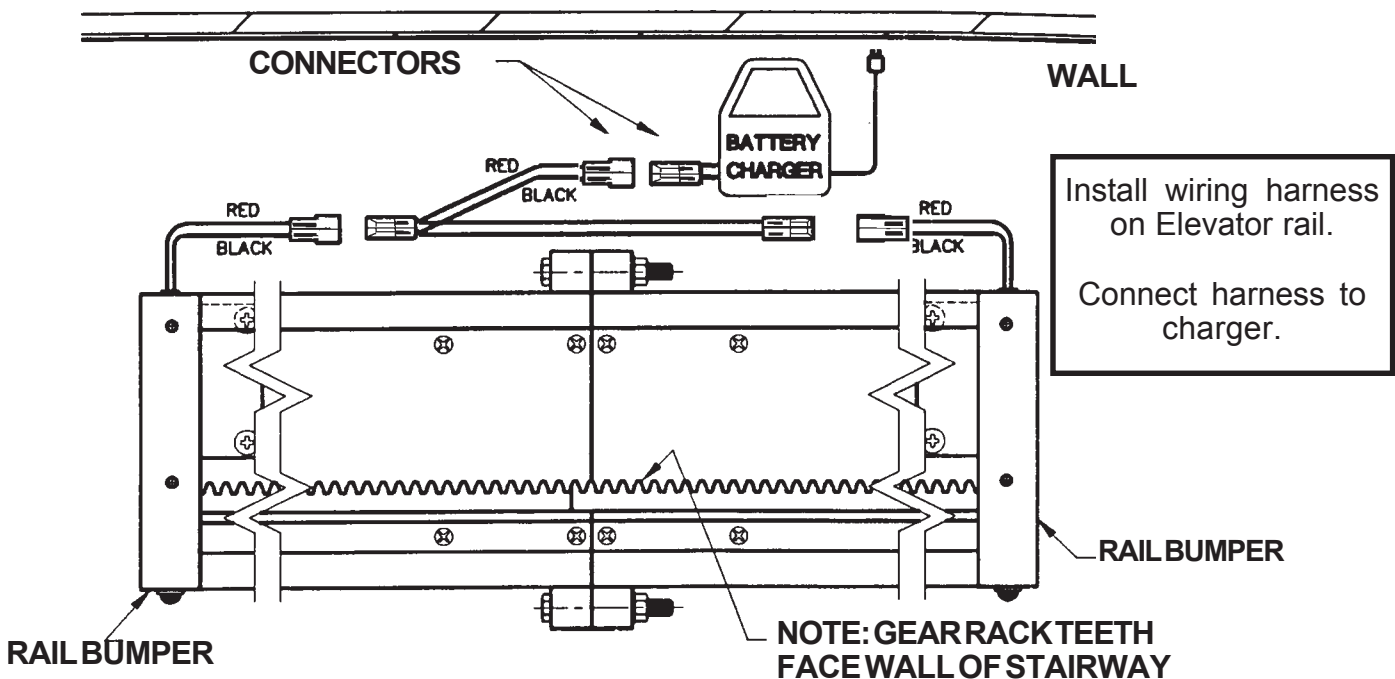

INSTALLATION

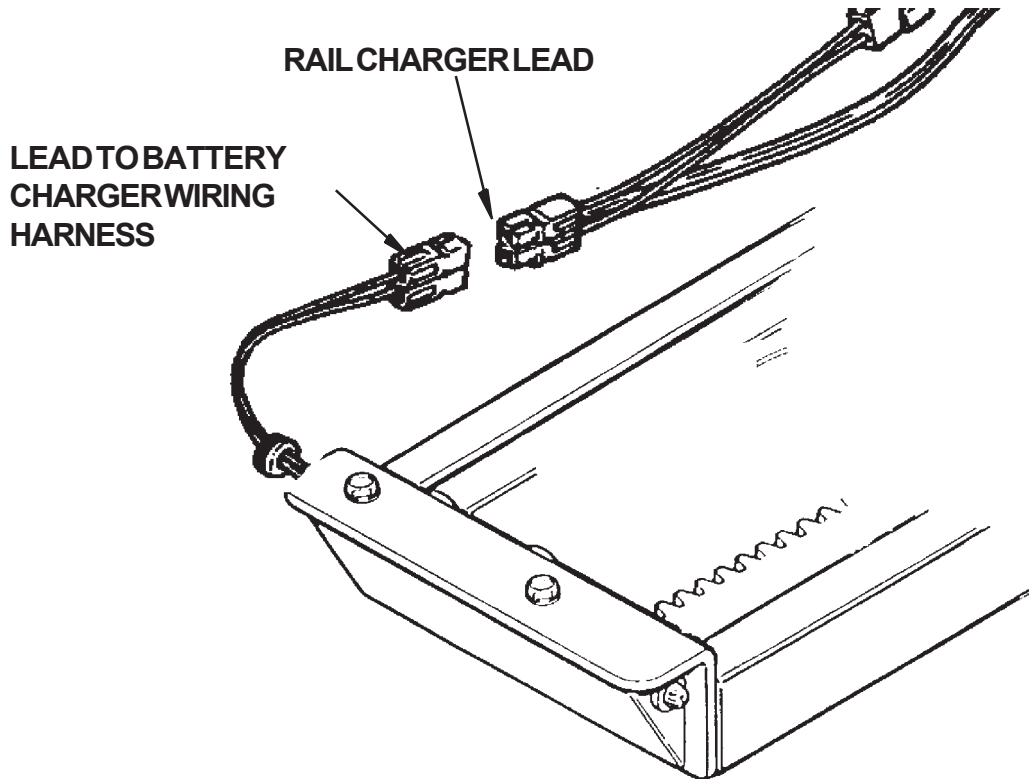

INSTALLATION SUGGESTION:

AFTER ROUTING THE WIRE HARNESS OUT OF SIGHT, A SMALL PIECE OF DOUBLE SIDED FOAM TAPE CAN BE APPLIED TO THE HARNESS PLUGS FOR ATTACHMENT UNDER THE RAIL.

**NOTE:
IF THE CHARGER PLUG AND WIRE ARE LOCATED IN A VULNERABLE LOCATION, USE OF A PLUG LOCK IS RECOMMENDED TO PREVENT ACCIDENTAL UNPLUGGING. PLUG LOCKS ARE AVAILABLE AT HARDWARE AND DEPARTMENT STORES.**

- [] Route the charger wiring harness along the back side of the rail and secure it to the rail mounting clamps with wire ties. Be sure that this wiring is mounted securely to avoid damage.
- [] Coil any excess harness wire and attach it to a rail clamp located under the rail.

NOTE: THE CHARGER SHOULD BE PLUGGED INTO A HOUSEHOLD OUTLET ALL OF THE TIME. THE ELEVATOR IS DESIGNED SO THAT THE BATTERIES WILL BE CHARGED WHEN THE CARRIAGE IS AT ONE OR THE OTHER END OF THE RAIL. IT IS IMPERATIVE THAT THE CARRIAGE BE "PARKED" AT THE END OF THE RAIL WHEN NOT IN USE TO MAINTAIN FULL BATTERY CHARGE. THE ONLY EXCEPTION IS WHEN TURNING UNIT 'OFF' (SEE LONG TERM STORAGE SECTION).

IN AN INSTALLATION WHERE THE CARRIAGE CANNOT BE PARKED AT THE END OF THE RAIL (STAIRWAYS WITH A DOOR AT THE TOP, FOR EXAMPLE), THE CARRIAGE SHOULD BE RUN TO THE OTHER END OF THE RAIL WITH THE REMOTE CALL/SEND TRANSMITTER WHEN NOT IN USE. THIS WILL ENSURE THAT THE BATTERIES REMAIN FULLY CHARGED.

IMPORTANT

ALWAYS "PARK" THE CARRIAGE AT THE UPPER OR LOWER END OF THE RAIL TO KEEP BATTERIES FULLY CHARGED

PILOT LAMP INDICATES "CHARGING CONTACT" AND CORRECT POLARITY. BE SURE CHARGER IS PLUGGED INTO A "LIVE" OUTLET.

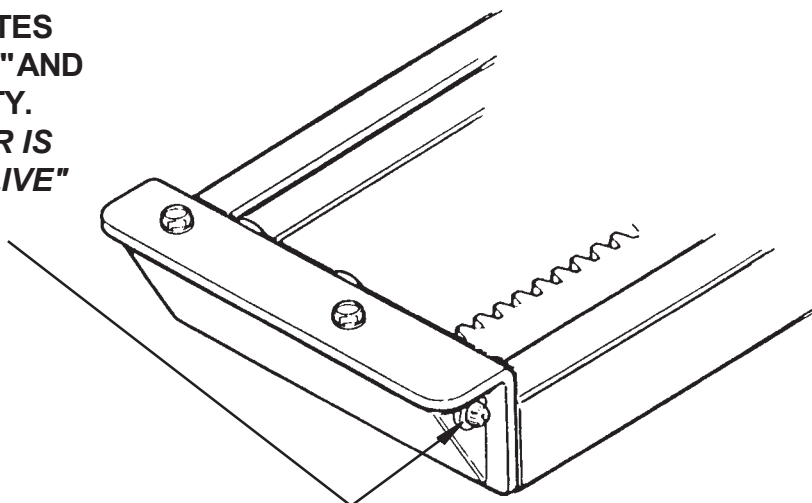

INSTALLATION

SPEED ADJUSTMENT

A provision for adjusting speed is one of the unique features of the SRE-1550 Stairway Elevator. The **Speed Adjustment Potentiometer** is located on the top of the Carriage. Adjust according to the following procedure:

- 1.) Loosen the collet nut on the Speed Control Potentiometer approximately one-half turn.
- 2.) Turn the Potentiometer completely in the counterclockwise direction. This is the starting point. Turn the Potentiometer in the clockwise direction, aligning the slotted shaft with the weight range of the user.
- 3.) The speed may be adjusted by turning the slotted shaft on the Potentiometer (clockwise = faster, counterclockwise = slower). With the customer seated on the unit, perform several test runs to arrive at the most appropriate speed setting.
- 4.) When the speed has been set satisfactorily, retighten the collet nut.
- 5.) Recheck the speed.

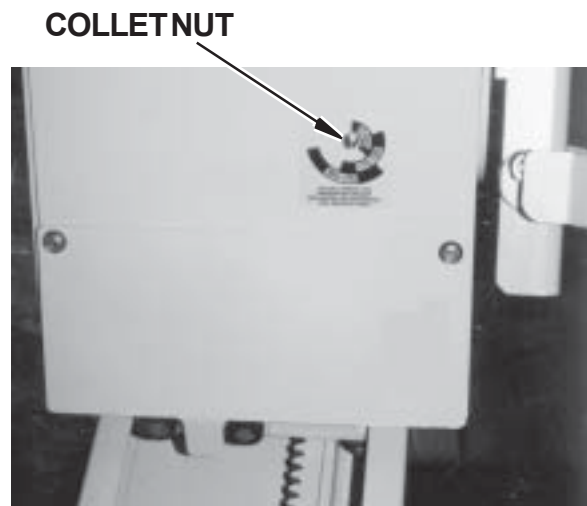
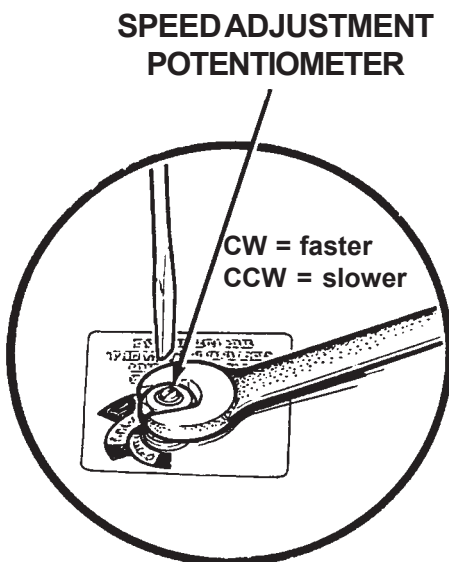

**TURN POTENTIOMETER
COUNTERCLOCKWISE**



THEN

**TURN CLOCKWISE, ALIGNING SLOT-
TED SHAFT WITH WEIGHT RANGE OF
CUSTOMER**

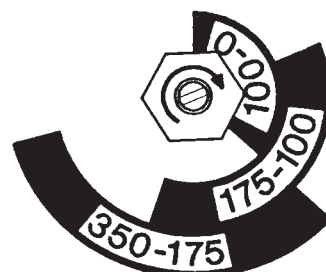

INSTALLING CALL/SEND ANTENNA-COMMERCIAL UNIT

Install the Call/Send Antenna on the rear of the carriage as shown below.

Secure the antenna by snapping it into the clip.

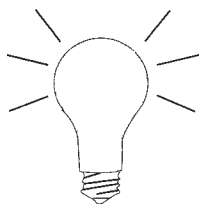
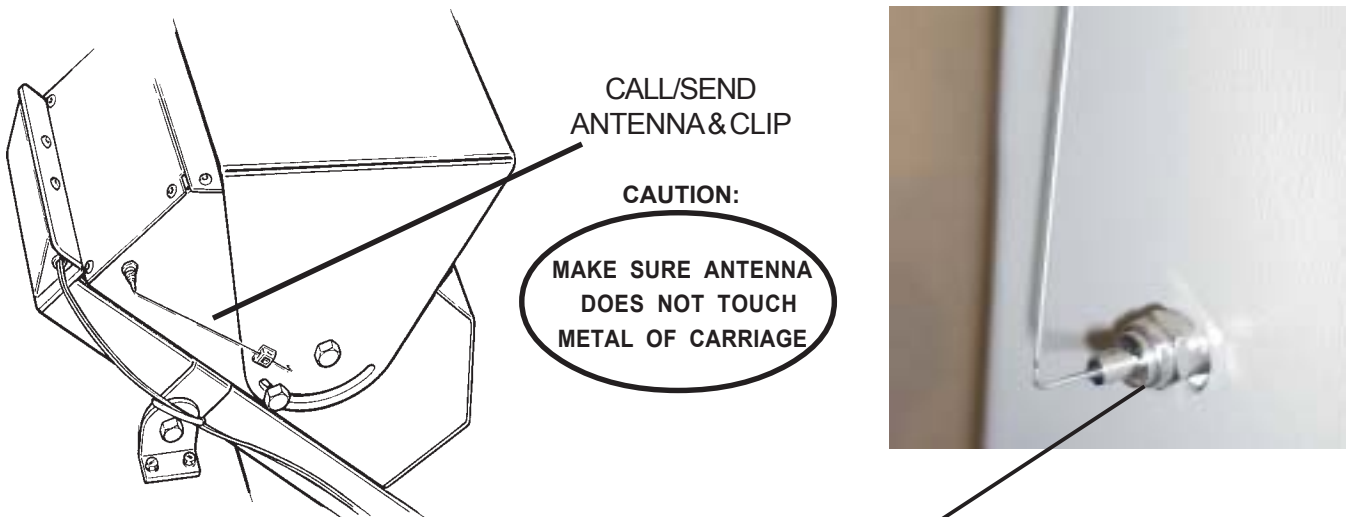

As you start to thread the connector, twist the antenna back and forth to make sure that you insert the antenna as far as possible into the receptacle. This action ensures that the necessary contact is made for proper operation of the Stairway Elevator.

INSTALLATION

OVERSPEED-COMMERCIAL UNITS ONLY

ALIGNMENT

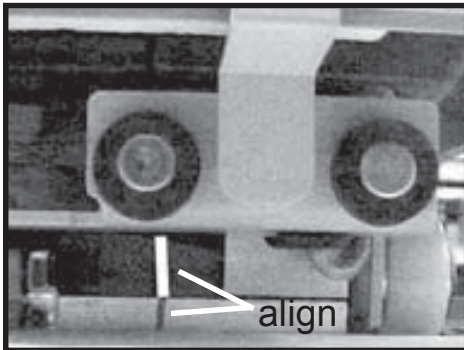

looking at end of
carriage

Before installing the carriage, the overspeed cam must be adjusted to line up with the overspeed housing.

Looking at the end of the carriage, align the white mark on the cam with the white mark on the overspeed housing.

Slide the carriage on the rail, making sure not to alter the alignment.

RESETTING THE OVERSPEED

If the overspeed is tripped during installation or service operations, reset the cam by rotating it back to its detent position.

By by-passing the overspeed switch and running up the drive unit, it is possible to manually rotate the cam.

In the event of a failure which activates the overspeed, it will be necessary to remove the complete drive unit from the rail, and to return the unit to the dealer or manufacturer for diagnosis and repair before putting the unit back into service.

CIRCUIT BREAKER

The on/off switch is built into the circuit breaker which is provided to protect the battery, controller and motor circuits in the Elevator carriage. It is unlikely that this circuit breaker will ever trip in normal use, but if the Elevator should fail to operate, check the circuit breaker and reset it if necessary. If the circuit breaker should trip, determine the cause and correct the situation.

The most likely cause of a tripped circuit breaker would be a foreign object jamming the rail or gear rack or overloading the elevator by exceeding its rated load capacity.

A fuse has been provided to protect the battery charging circuit and the Call / Send electronics. The Elevator is shipped with this fuse installed.

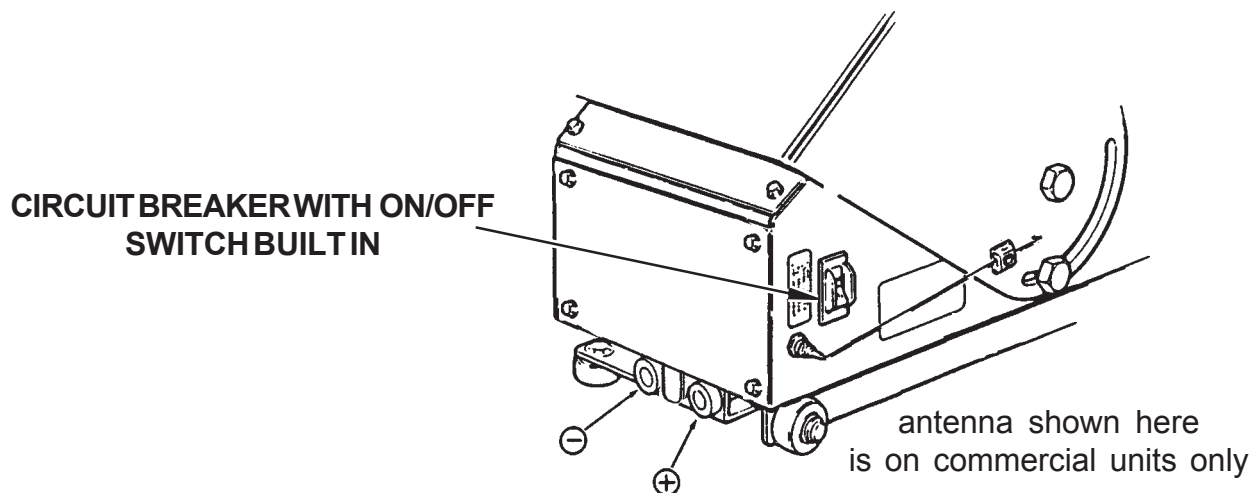

REPLACING A "BLOWN" FUSE:

- [] Turn "OFF" the unit using the "ON" / "OFF" switch on the back of the unit.
- [] Disconnect the battery charger from the rail charge lead.
- [] Remove carriage cover.
- [] Determine and repair any short circuit which may have caused the fuse to blow.

ELECTRICAL

- [] Use a fuse puller to remove the "old" fuse from PC board spring clips (be careful to avoid breaking the glass).
- [] Replace the fuse using only an MDL3.5A time-delay type fuse.
- [] Turn the power switch to "ON".
- [] Replace the carriage cover.
- [] Reconnect the battery charger Leads.
- [] Test the unit for proper operation.

***NOTE:**
A FLASHING GREEN LIGHT ON THE CHARGER INDICATES A PROBLEM WITH THE BATTERY. IF THE BATTERY HAS NOT REACHED THE END OF THE FIRST STAGE OF THE OPERATION WITHIN 18 HOURS, THE CHARGER MAY DETERMINE THAT A PROBLEM EXISTS WITHIN THE BATTERY.

WHEN THE INSTALLATION IS COMPLETE, TEST THE UNIT FOR CORRECT OPERATION OF CALL/SEND, 'ON/OFF' SWITCH, FOOTREST, SAFETY SWITCHES, CARRIAGE LIMIT SWITCHES AND SEAT SAFETY SWITCH.

TRAIN THE CUSTOMER TO USE THE STAIRWAY ELEVATOR CORRECTLY AND SAFELY. BE SURE TO HAVE THEM OPERATE THE UNIT WHILE YOU ARE THERE TO ANSWER ANY QUESTIONS OR CONCERNS.

BATTERY CHARGER

BATTERY CHARGER SEQUENCE IS AS FOLLOWS:

RED LED 'ON' = AC Power on (power cord plugged in)

YELLOW CONTINUOUS LED = Batteries charging

FLASHING YELLOW LED = Batteries are 80% charged

GREEN CONTINUOUS LED = Batteries in "charge completing" mode (or float / standby condition)

FLASHING GREEN LED = Possible battery fault detected after battery has failed to reach the end of the first stage of charging (continuous yellow LED) after approx. 18 hours. Consult an authorized Bruno dealer.

BATTERY CHARGER FUSE REPLACEMENT

If the charger is subject to a power line surge, the AC input fuse may 'BLOW' This fuse is located beneath the power cord from the wall outlet to prevent shock hazard, to replace fuse:

- 1) Remove Power Cord from wall outlet and charger socket.
- 2) Pull out on the fuse access panel.
- 3) Remove fuse.
- 4) Replace with the same size and type:
(BUSS # GMC 4) 5 x 20mm-4AMP/125V-TIME LAG

LONG-TERM STORAGE

TURNING THE UNIT OFF

When the Elevator will not be in use for an extended period of time:

- 1) moved the seat/carriage 2"-3" away from the lower charge contacts,
- 2) turn off the circuit breaker, then
- 3) unplug the charger from the wall outlet.

DO NOT unplug the charger from the wall outlet without first turning off the circuit breaker. Failure to first turn off the circuit breaker will result in battery discharge or premature battery failure.

TURNING THE UNIT ON

To turn the Elevator back on:

- 1) turn on the circuit breaker, then
- 2) plug the charger back into the wall outlet.

NOTE: The batteries may require recharging before normal use if the Elevator has remained in the 'off' position for an extended period of time. To do so, simply move the unit to the LOWER charge contacts, and reconnect the charger to the wall outlet (circuit breaker 'on').



California Proposition 65 Workplace Warning Sign

1/99

MAINTENANCE

YEARLY MAINTENANCE OPERATIONS

STAIRWAY ELEVATORS

Clean rails, racks and wheels. Regrease.

Check for dry and/or worn belts. Lubricate.

Check rail wear. There should be no groove.

Clean charging contacts (both carriage and rail ends) with Scotch Brite®.

Check battery voltage (load test).

Check safety switches (footrest, carriage, seat).

Check armrest switch and keyswitch (if applicable).

Check battery charger output:

- Load test using remote controls: check voltage while carriage is traveling up.
- Test with carriage against contacts.
- Test with carriage away from contacts.
- Check contacts and lights.

Check speed.

Check seat belt for wear and proper operation.

Examine exposed wiring. Are there any cuts or abrasions?

Verify operation of seat swivel mechanism. Does it move easily and lock in place correctly?

Check that all hardware is properly tightened.

TROUBLESHOOTING

UNIT FAILS TO OPERATE

Check circuit breaker. Reset if necessary.

Check battery connections.

Check footrest safety switches to see if one of these limit switches is depressed. Sliding safety tray below footrest should slide freely and should not stick in a position which would depress one of the safety switches.

Check for discharged batteries. Battery voltage should be in a range of 16-28 VDC.

Commercial units only: Check fuse. Replace if necessary.

UNIT OPERATES SLOWLY, LACKS POWER

Check for discharged batteries.

Check setting of speed control potentiometer.

Check for loose connections.

Check to make sure charger is plugged in and working.

CONTROLS OPERATE BACKWARDS AND UNIT GOES "UP" SLOWLY AND "DOWN" FAST

Unit has been connected for left-hand operation but is installed on the right-hand side of the stairs (or vice versa).

Make correct connections according to instructions in the installation manual, section on *Reversing Operations*.

TROUBLESHOOTING

**UNIT OPERATES
ERRATICALLY
OR
INTERMITTENTLY WITH
REMOTE
CALL/SEND**

Check all safety mechanisms, including swivel seat safety switch.

Change the delay setting on the receiver board to 900 mSec.

Reorient the transmitter (to point directly at the carriage).

Consult your dealer, an experienced technician or call our Technical Service Department at 1-800-882-8768.

**UNIT OPERATES ER-
RATICALLY OR INTER-
MITTENTLY WITH A
RIDER USING THE
ARMREST MOUNTED
CONTROL SWITCH**

Check swivel seat safety switch.

Check to see that the footrest safety tray is not dragging on the stair nosing or hitting debris on the stairs.

If necessary, reposition the stair rail mounting brackets to correct the problem.

Check the rail for debris that may bump safety switches (footrest and carriage panels).

**UNIT WILL NOT
OPERATE UNLESS
THE SEAT IS
POSITIONED SO THAT
IT FACES THE OPEN SIDE OF
THE STAIRS**

This is correct lift operation.

A safety switch in the seat swivel prevents the unit from operating with the seat "out of position".

**UNIT WILL NOT
OPERATE WITH
CALL/SEND
REMOTE**

Check batteries in remote call/send unit.

Aim transmitter at the carriage

Transmitters must be 'learned' to receiver.

**UNIT DOES NOT SHUT
OFF WHEN IT HITS THE
BUMPER AT THE END OF
THE RAIL**

Connections were not made correctly when changing unit from left-side to right-side installation.

Consult installation manual for diagram of correct wiring configuration.

Verify correct operation of limit switch in carriage assembly.

**ROUGH OR
CHATTERING RIDE**

Wipe down rail.

Apply a small amount of grease to the gear rack **only**.

IR TRANSMITTER HARDWARE KIT RESIDENTIAL

ITEM NO.	QTY.	PART NO.	DESCRIPTION
1	2	ANC-00002 #4/#6/#8 X .88" LG RIBBED PLASTIC WALL ANCHOR	
2	1	PFS-02003 #2 X .75" LG PHILLIPS FLAT HEAD SELF-TAPPING SCREW	
3	2	PSM-08002 #8 X .75" LG PHILLIPS HEAD SHEET METAL SCREW	

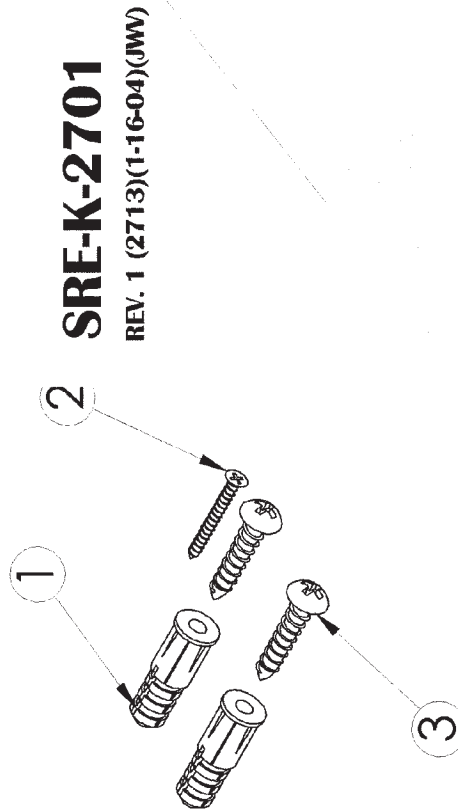

SRE-K-2701
REV. 1 (2713)(1-16-04)(JWW)

tolerances: .x ±.030 .xx ±.015 .xxx ±.005	used on: CRE-2100/SRE-1540/SRE-1550
angles: ±.5°	
part name	KEYED CALL/SEND HARDWARE KIT
material	
drawn by: RJH	scale: 1:1
checked	date: 3-19-01
	size: A
	drawing no: SRE-K-055A
	rev: ~

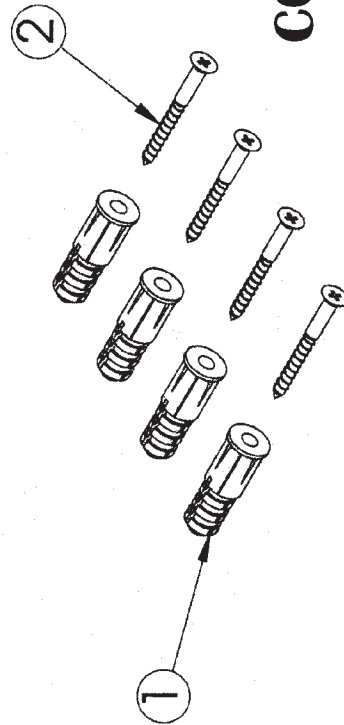

COMMERCIAL

ITEM NO.	QTY.	PART NO.	DESCRIPTION
1	4	ANC-00002 #4/#6/#8 X .88" LG RIBBED PLASTIC WALL ANCHOR	
2	4	PFW-04001 #4 X 1" LG PHILLIPS FLAT HEAD WOOD SCREW	

HARDWARE



M3 X .5 NYLON INSERT LOCK NUT



M4 NYLON INSERT LOCK NUT

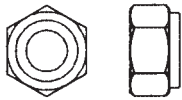

M6 NYLON INSERT LOCK NUT

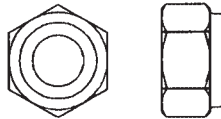

M8 NYLON INSERT LOCK NUT

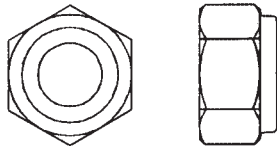

M10 NYLON INSERT LOCK NUT



M3 HEX NUT (PLATED)



M6 HEX NUT (PLATED)



M8 HEX NUT (PLATED)



M10 HEX NUT (PLATED)

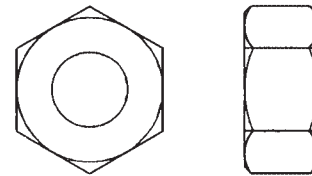

M12 HEX NUT (PLATED)

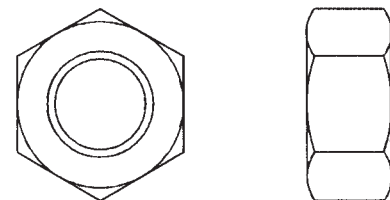

M14 HEX NUT

HARDWARE

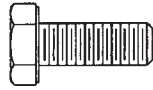

M6 x 16mm

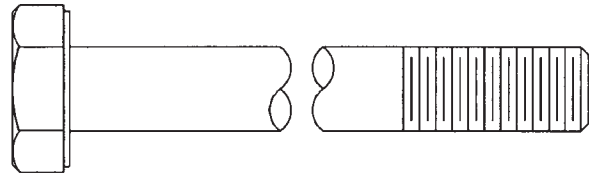
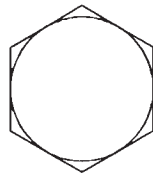

M12 x 220mm

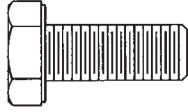
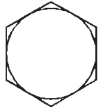

M8 x 20mm

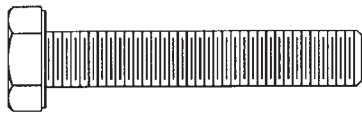
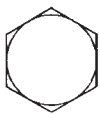

M8 x 45mm

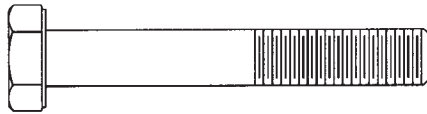
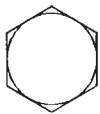

M8 x 55mm

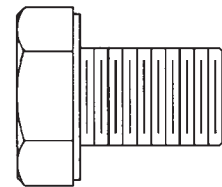
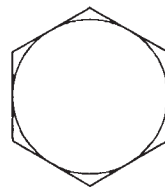

M14 x 20mm

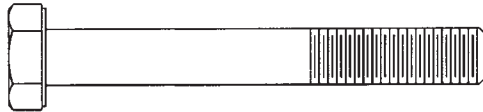
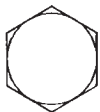

5/16-18 X 2.5" LG HEX HEAD CAP SCREW

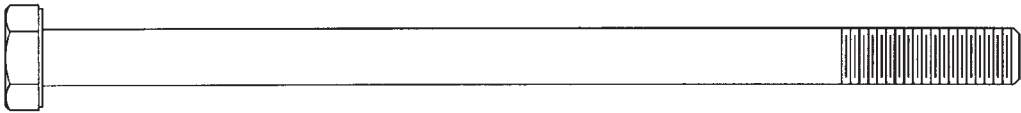
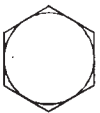

M8 x 140mm

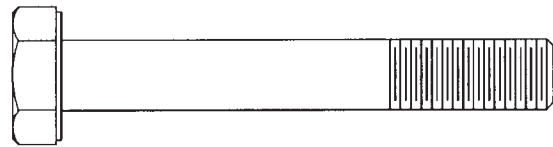
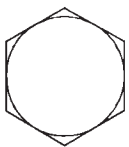

M10 x 70mm

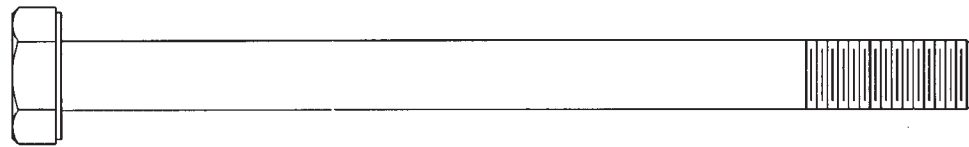
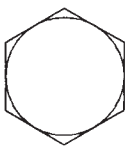

M10 x 130mm

HARDWARE



M6 x 1 x 20mm LG
FLAT SOCKET HD CAP SCREW



M5 X .8 X 16MM LG
HEX WASHER HEAD
MACHINE SCREW

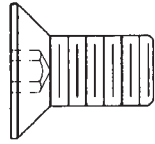
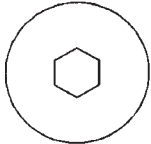

M10 x 1.5 x 20mm LG
FLAT SOCKET HD CAP SCREW

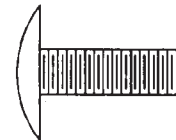

1/4-20 x .75" LG
PHILLIPS TRUSS HD
MACHINE SCREW

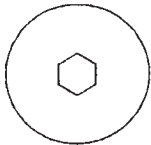

M10 x 1.5 x 30mm LG
FLAT SOCKET HD CAP SCREW



M2.5 x .45 x 16mm LG
PHILL PAN HD MACHINE SCREW



#8 x 3/4" PHILIPS SHEET METAL
METAL SCREW (ZINC PLATED)



M6.3 x 50mm SLOTTED
HEX HD SHEET METAL SCREW



M8 X 15MM X 10MM LG SET SCREW

HARDWARE



M3 x 25mm PFHMS



M4 x 15mm PFHMS



M4 x 30mm PFHMS

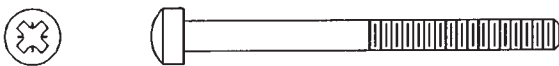

M4 x 50mm PFHMS

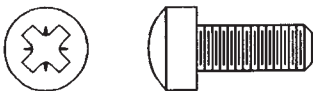

M6 x 15mm PFHMS

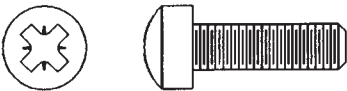

M6 x 20mm PFHMS

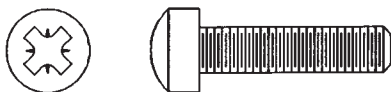

M6 x 25mm PFHMS

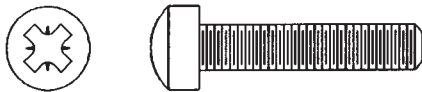

M6 x 30mm PFHMS



M6 x 40mm PFHMS



M5 X 16 MM LG HEX WASHER
HEAD MACHINE SCREW



M3 EXT.
TOOTH LOCK WASHER



M4 EXT. TOOTH
LOCK WASHER

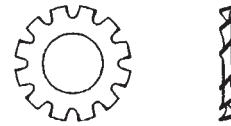

M8 EXT. TOOTH
LOCK WASHER

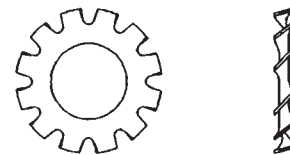

M10 EXT.
TOOTH LOCK WASHER

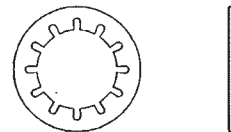

M10 INTERNAL TOOTH
LOCK WASHER

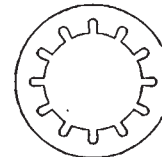

M12 INTERNAL TOOTH
LOCK WASHER

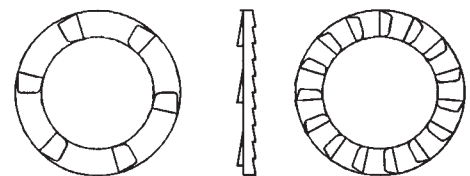

M14 LSAFETY LOCK WASHER,
BOSSARD BN 1938

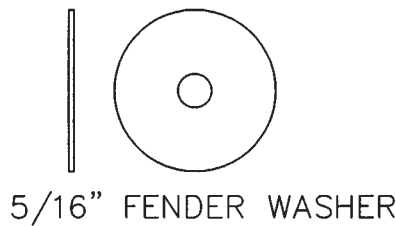

WIRING SCHEMATIC-RESIDENTIAL

- APP
- ENG
- IC
- ASK
- SHP
- UPH
- TS
- MAN
- UL

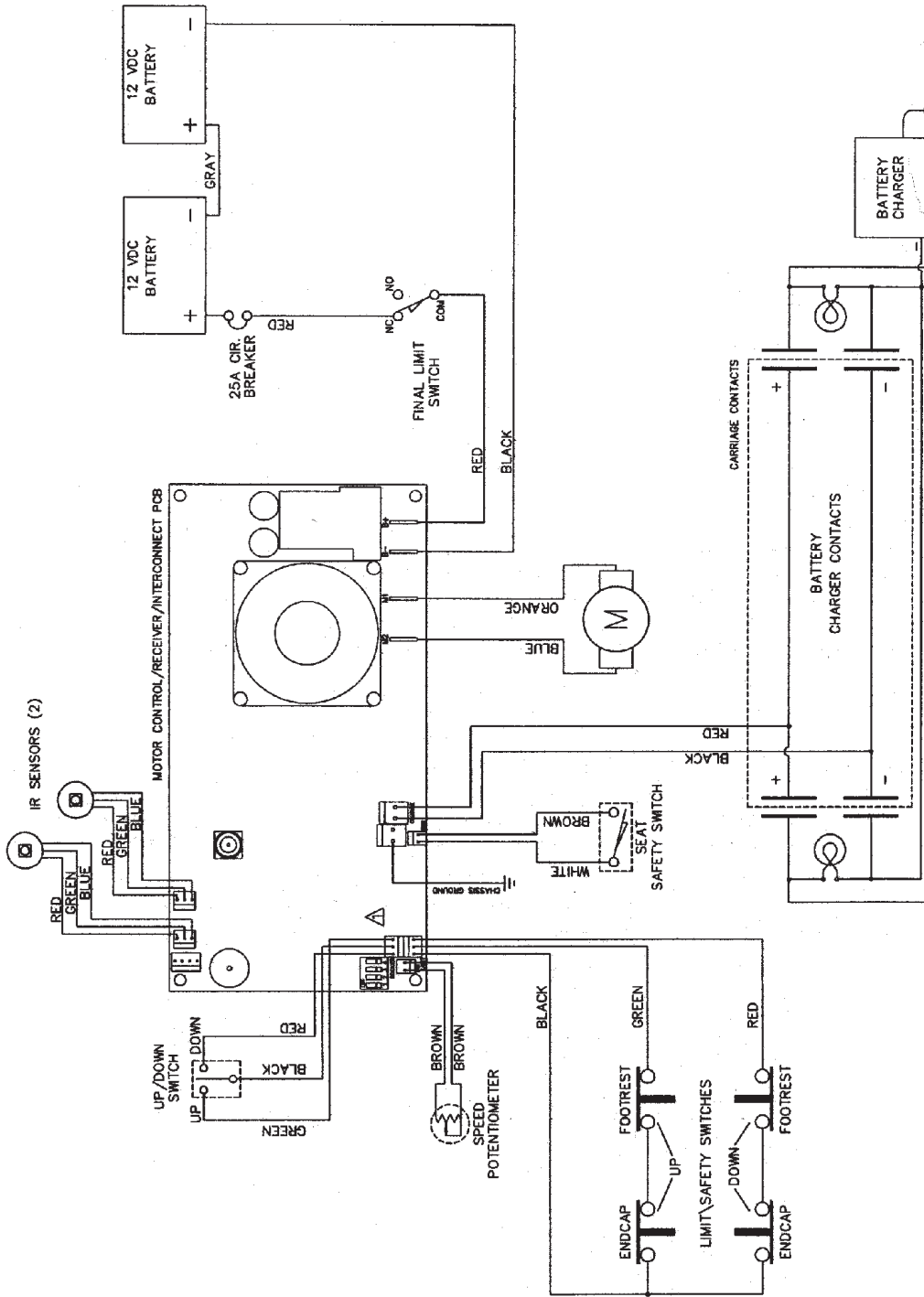

SRE-1540, SRE-1550

BRUNO
UL LISTED
UL 5083 CERTIFIED
1780 EXECUTIVE DRIVE, P.O. BOX 84
OCONEGO, WI 53066
(262) 567-4990
FAX (262) 535-5304

WIRING SCHEMATIC

Drawn by: KAS
 Checked by: []
 Date: []
 Part No: []
 Rev: []
 Sheet: 2-3-04
 Title: SCH-00100
 Page: 1

Rev	By	Date	Description
1	KAS	12/29/02	Initial Issue

This product is the property of Bruno Independent Living Aids, Inc. No rights are granted to copy, reproduce, or any portion thereof without the written permission of Bruno Independent Living Aids, Inc.

WIRING SCHEMATIC-COMMERCIAL

- APP
- ENG
- IC
- ASM
- SHP
- UPH
- TS
- MAN
- UL

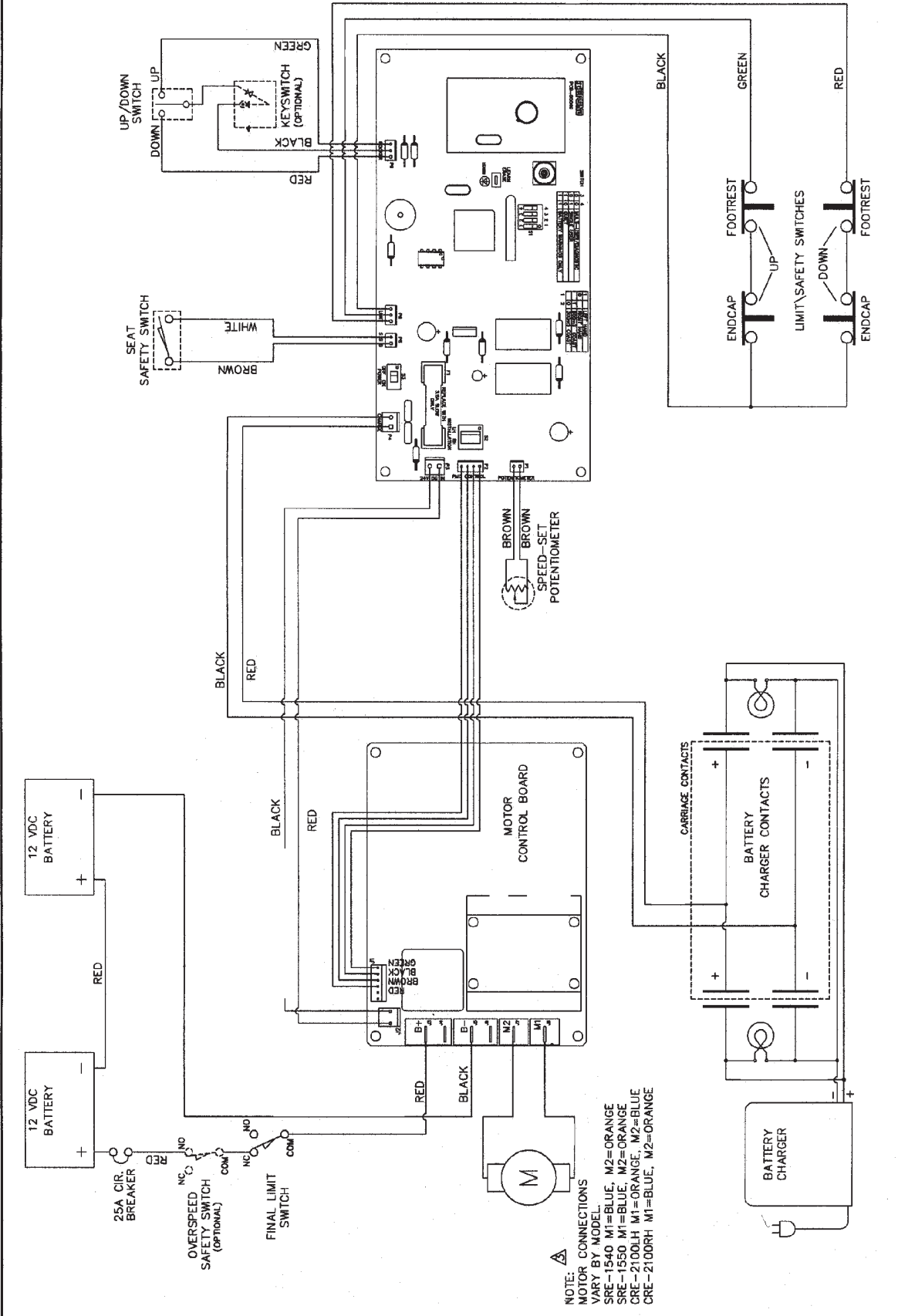

NOTE:
 ADD MOTOR CONNECTIONS VARY BY MODEL:
 SRE-1540 M1=BLUE, M2=ORANGE
 SRE-1550 M1=BLUE, M2=ORANGE
 CRE-2100LH M1=ORANGE, M2=BLUE
 CRE-2100RH M1=BLUE, M2=ORANGE

	Information: 1-800-828-8288 Fax: 857-855-8288	Form an: CRE-2100, SRE-1540 SRE-1550
	WIRING SCHEMATIC	
ISO 9001 CERTIFIED 1790 BRUNO DRIVE, BOX 84 GARDEN CITY, NJ 07633 (202) 567-4990 FAX (202) 953-5304	Drawn by: KAS Date: 8-5-96	Part must be free of markings and tags, snap tags or controls, etc.

No.	QTY	Part	Rev	By	Date
3	2514	1-2-0-KAS			
2	2080	3-15-0-KAS			
1	2078	3-5-0-KAS			

ADD MOTOR CONNECTION WIRE COLOR NOTE.
 This network is the property of Bruno Independent Living Aids, Inc. No parts are provided to suit such requirements for any purpose other than (1) product manufacture or maintenance, or (2) the furnishing of services to Bruno Independent Living Aids, Inc.

EXPLODED VIEW AND BILL OF MATERIALS

SWITCH HOUSING ASSEMBLY (1550/1560)

ITEM NO.	QTY.	PART NO.	DESCRIPTION
1	1	BUS-63002	ø5/8" OPEN/CLOSED BUSHING
2	2	CPP-10201	1" X 2" RECTANGULAR CAP PLUG (16 GA)
3	1	RSW-00104	SPDT MOMENTARY ROCKER SWITCH
4	1	SRE-00490	STD. ROCKER SWITCH HARNESS
5	1	SRE-00577	SWITCH BRACKET WELDMENT

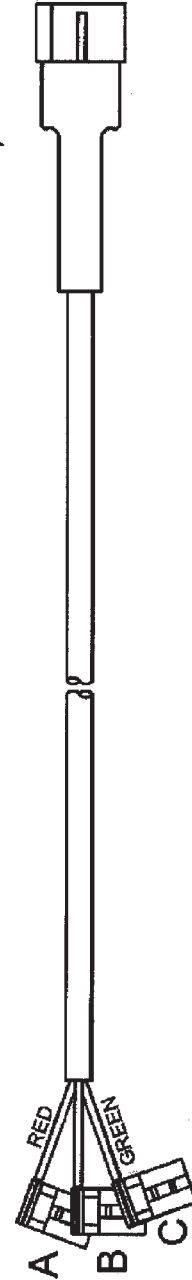
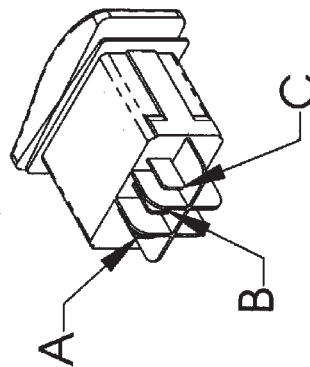
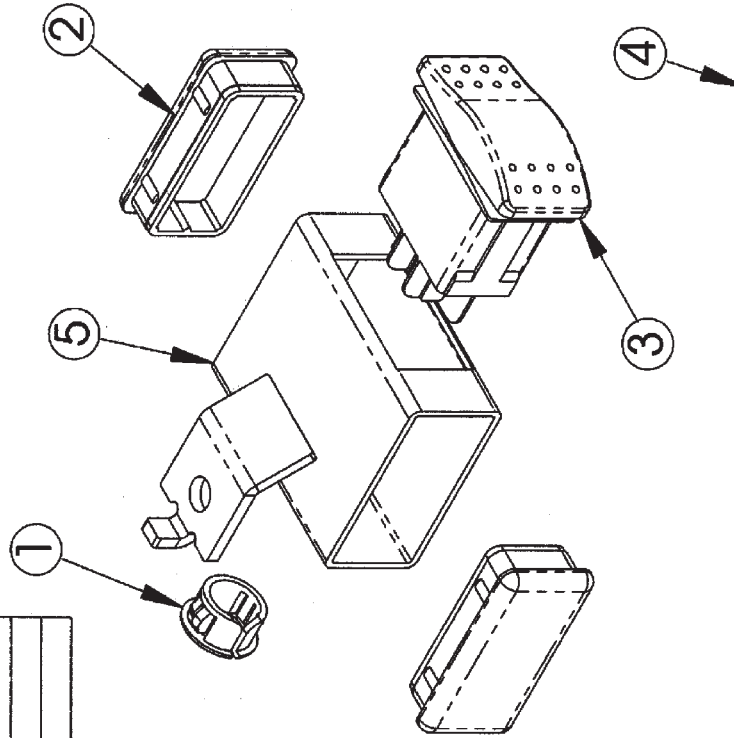

SRE-00384
REV. 1 (820)(7-22-96)(RJH)

KEYED SWITCH HOUSING ASSEMBLY (1550)

EXPLODED VIEW AND BILL OF MATERIALS

ITEM NO.	QTY.	PART NO.	DESCRIPTION
1	1	BUS-63002	5/8" OPENCLOSED BUSHING
2	1	CRE-00281	ARMREST KEYSWITCH JUMPER
3	1	KYS-00108	KEYSWITCH (2 POS., KEYCODE #252, .25" SPADE TERM., KEYPULL POS. 1 ONLY)
4	1		FACEPLATE (PBS-00108)
5	1		HEX NUT (PBS-00108)
6	2	MHW-05001	M5 X .8 X 16MM LG HEX WASHER HEAD MACHINE SCREW
7	2	MUNT-05001	#8 U-NUT (BLACK)
8	1	RSW-00104	SPDT MOMENTARY ROCKER SWITCH
9	1	SRE-00459	KEYLOCK CONTROL HARNESS
10	1	SRE-00602	INNER SWITCH HOUSING
11	1	SRE-00604	OUTER SWITCH HOUSING WELDMENT

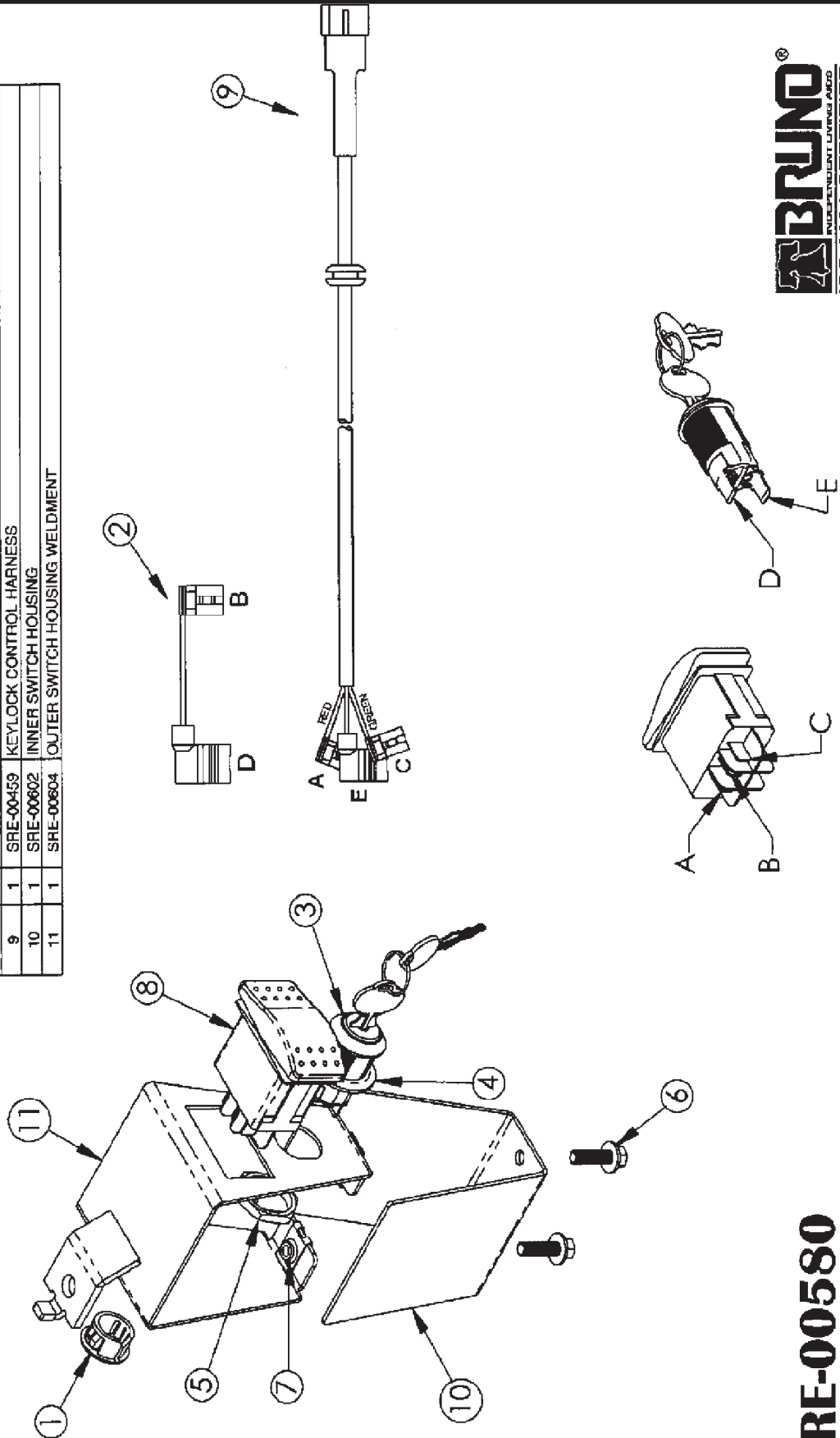

SRE-00580
REV. 3 (2090)(4-2-01)(RJH)

EXPLODED VIEW AND BILL OF MATERIALS

ELECTRA-RIDE II'

ITEM NO.	QTY.	PART NO.	DESCRIPTION
1	1	SRE-00217	BATTERY CHARGER ASSEMBLY
2	1	SRE-00384	SWITCH HOUSING ASSEMBLY
3	1	SRE-00528	SEAT ASSEMBLY (SRE-1550)
4	1	SRE-00529	FOOTREST ASSEMBLY (1540/1550)
5	1	SRE-00589	CHARGER MOUNTING STRAP
6	1	SRE-00594	CHARGER MOUNTING PLATE
7	2	SRE-00664	STD. IR. TRANSMITTER BRACKET/HDW. R
8	1	SRE-00668	CARRIAGE ASSEMBLY (1540/1550)
9	1	SRE-K-1518	CHARGER MOUNTING SCREWS

NOTE:
 *OPTIONAL EQUIPMENT IS AVAILABLE FOR THESE ITEMS.
 THE MOST COMMON OPTIONS ARE SHOWN FOR THIS DRAWING.

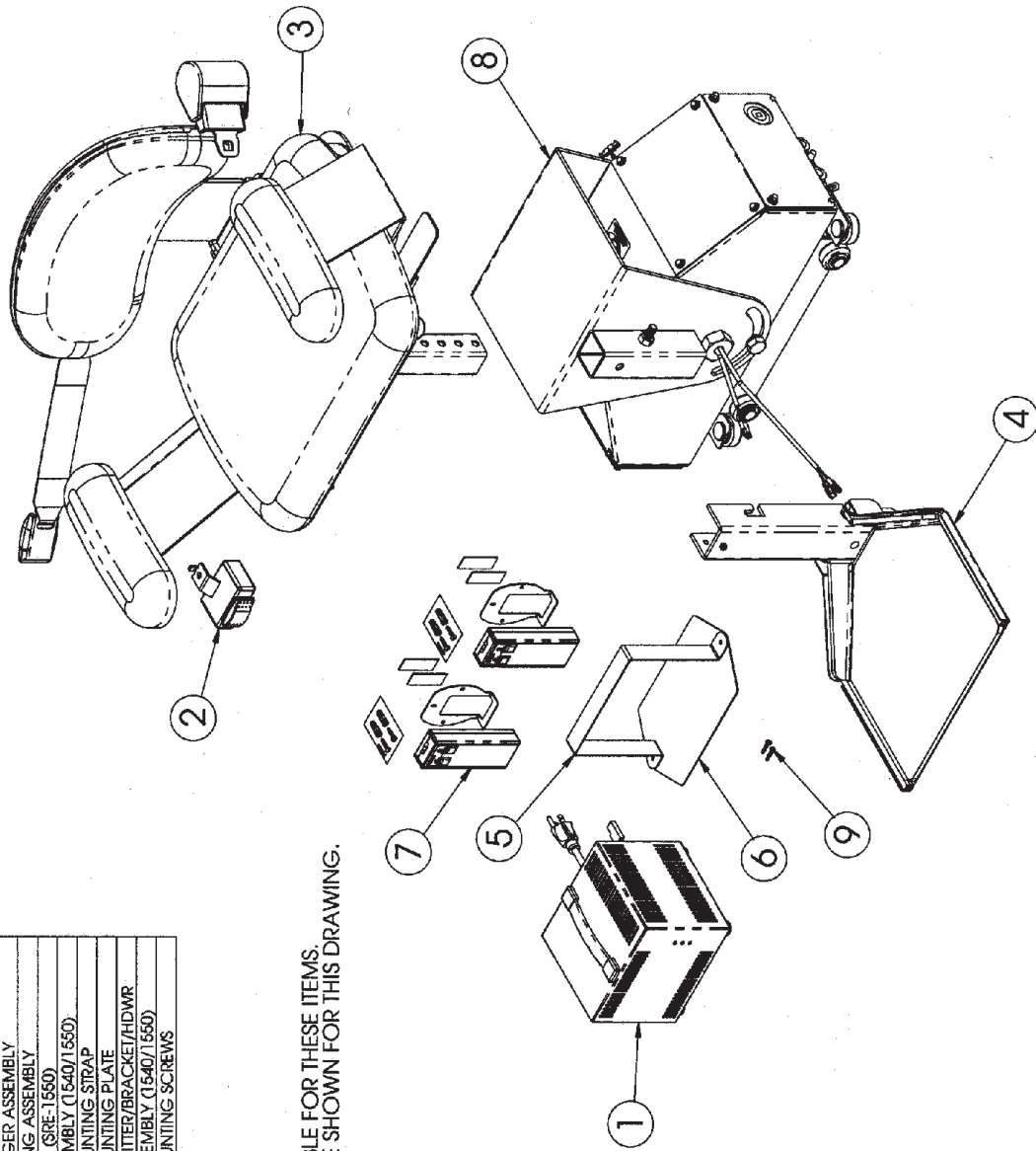

SRE-1550 SHEET 1 OF 2
REV. 5 (2716)(1-28-04)(JWV)

EXPLODED VIEW AND BILL OF MATERIALS

ELECTRA-RIDE II'

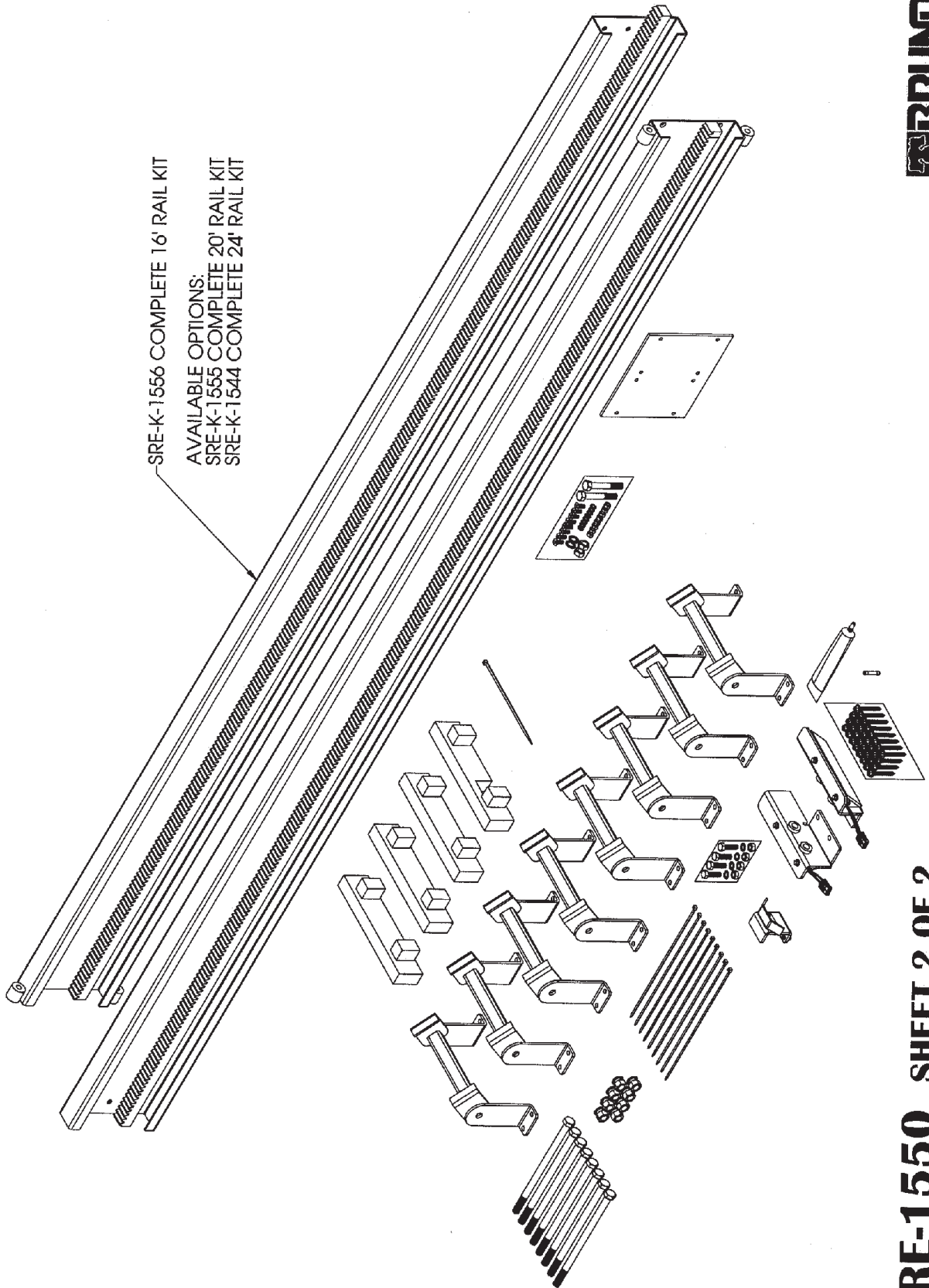

SRE-1550 SHEET 2 OF 2
REV. 5 (2716)(1-28-04)(JWV)

EXPLODED VIEW AND BILL OF MATERIALS

CARRIAGE ASSEMBLY (1540/1550)

ITEM NO.	QTY.	PART NO.	DESCRIPTION
1	2	BTFR-12002	12V 5.6/5.7 AH BATTERY (MAINTENANCE FREE)
2	1	CBK-25001	25A CIRCUIT BREAKER (ROCKER)
3	1	ETW-09001	#8 EXTERNAL TOOTH WASHER
4	4	GRR-19001	3/16" ID RUBBER GROMMET
5	2	ITW-09001	#6 INTERNAL TOOTH WASHER
6	1	LBL-00140	'DISCONNECT SWITCH' LABEL
7	1	LBL-00141	ASME A18.1/17.5 LABEL
8	3	MHCS-10002	M10 X 1.5 X 70MM HEX HEAD CAP SCREW
9	3	MHCS-14004	M14 X 2 X 25mm LG HEX HEAD CAP SCREW
10	16	MHW-05001	M5 X .8 X 15mm LG HEX WASHER HEAD MACHINE SCREW
11	2	MNSN-03051	M3 X .8 NYLON INSERT LOCK NUT
12	1	MNSN-10150	M10 X 1.5 NYLON INSERT LOCK NUT
13	2	MPLM-03001	M3 X .8 X 25mm LG PHILLIPS FILLISTER HEAD MACHINE SCREW
14	2	MSLW-14001	M14 SAFETY LOCK WASHER
15	16	MUNT-09001	M5 X .8 U-NUT (BLACK)
16	1	PS-00107	SPDT PUSHBUTTON SWITCH (SNAP-ACTION W/ROLLER LEVER)
17	1	PSM-09002	#3 X .75 LG PHILLIPS HEAD SHEET METAL SCREW
18	2	RCV-24003	I.R. RECEIVER WITH CABLES (CBE-125)
19	1	SRE-00032	PIVOT BOLT/PASS-THRU HARNESS ASSEMBLY
20	1	SRE-00248	SPEED LIMIT LABEL
21	1	SRE-00378	REAR COVER
22	1	SRE-00116	FRONT COVER
23	1	SRE-00430	ANGLE ADJUSTMENT BRACKET WELDMENT
24	1	SRE-00504	UPPER BATTERY ACCESS COVER
25	1	SRE-00648	CARRIAGE BASE ASSEMBLY (1550)
26	1	SRE-00658	SAFETY PANEL (LEFT)
27	1	SRE-00659	SAFETY PANEL (RIGHT)
28	1	SRE-00665	TOP COVER
29	1	SRE-00667	LOWER BATTERY ACCESS COVER
30	1	SRE-00669	ELECTRICAL PANEL ASSEMBLY (1540/1550)
31	1	STF-00104	STYROPORAM BLOCK
32	2	WRT-14401	6" LG. WIRE TIE (1/4" WIDTH)
33	2	WTM-00001	WIRE TIE MOUNT SELF-ADHESIVE (BLK)
34	2	WTM-00001	WIRE TIE MOUNT SELF-ADHESIVE (BLK)
35	1		SERIAL NO. LABEL (LARGE)

REMOVE WIRE CUPS (2) & DISCARD.
ASSEMBLE RING TERMINAL BETWEEN SCREW & ITW

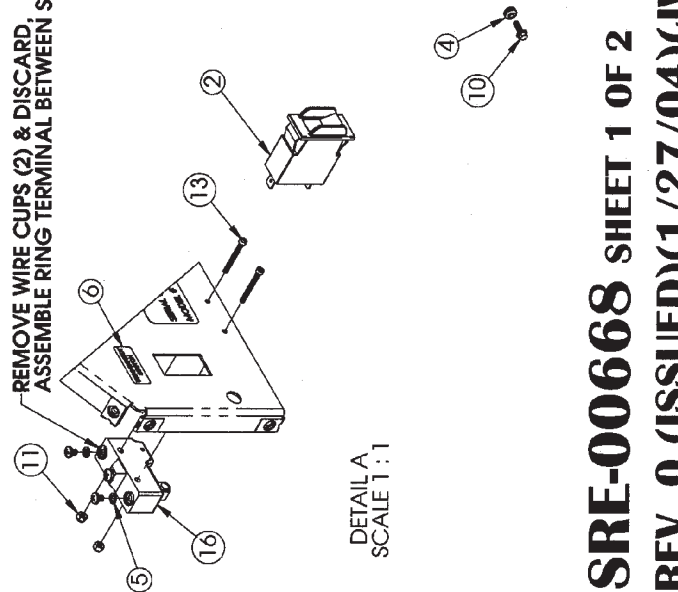

DETAIL A
SCALE 1:1



SRE-00668 SHEET 1 OF 2
REV. 0 (ISSUED)(1/27/04)(JWV)

EXPLODED VIEW AND BILL OF MATERIALS

CARRIAGE ASSEMBLY (1540/1550)

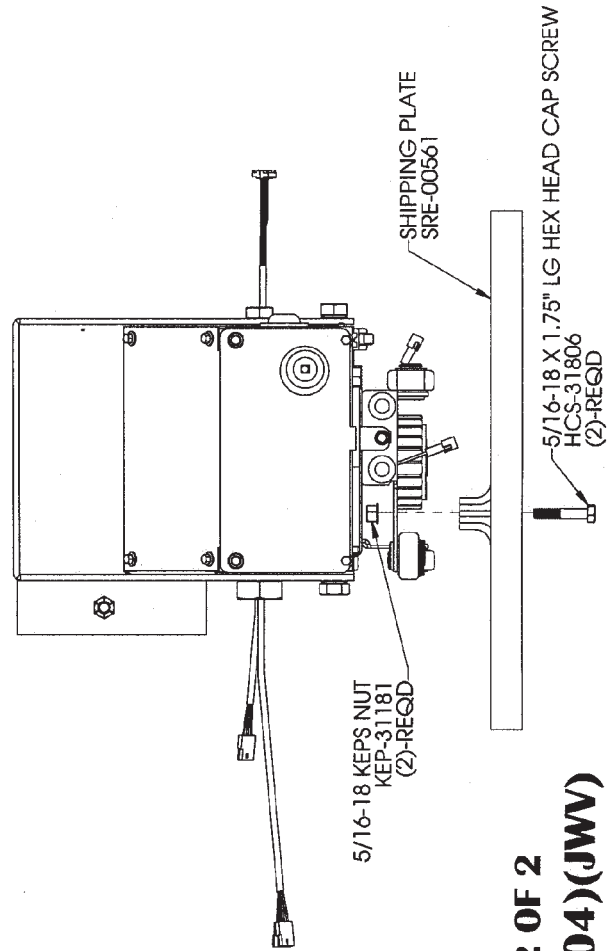
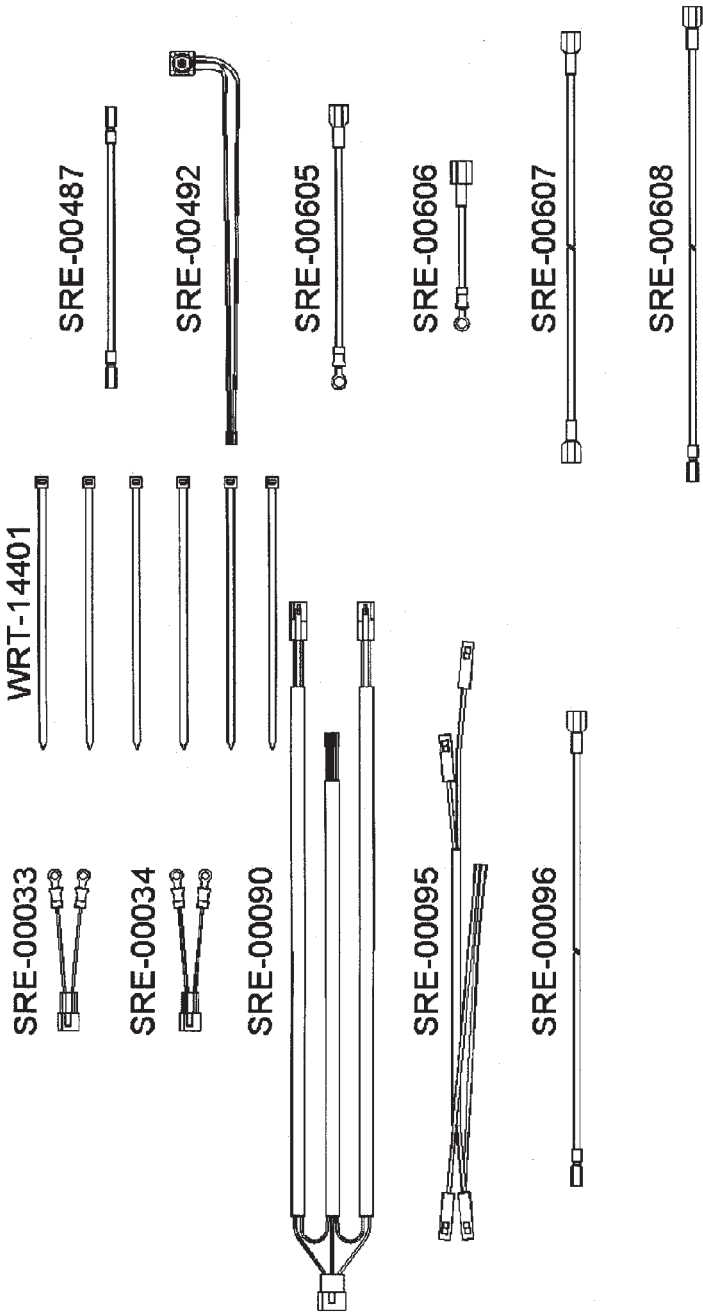

SRE-00668 SHEET 2 OF 2
REV. 0 (ISSUED)(1/27/04)(JWV)

EXPLODED VIEW AND BILL OF MATERIALS

CARRIAGE BASE ASSEMBLY (1550)

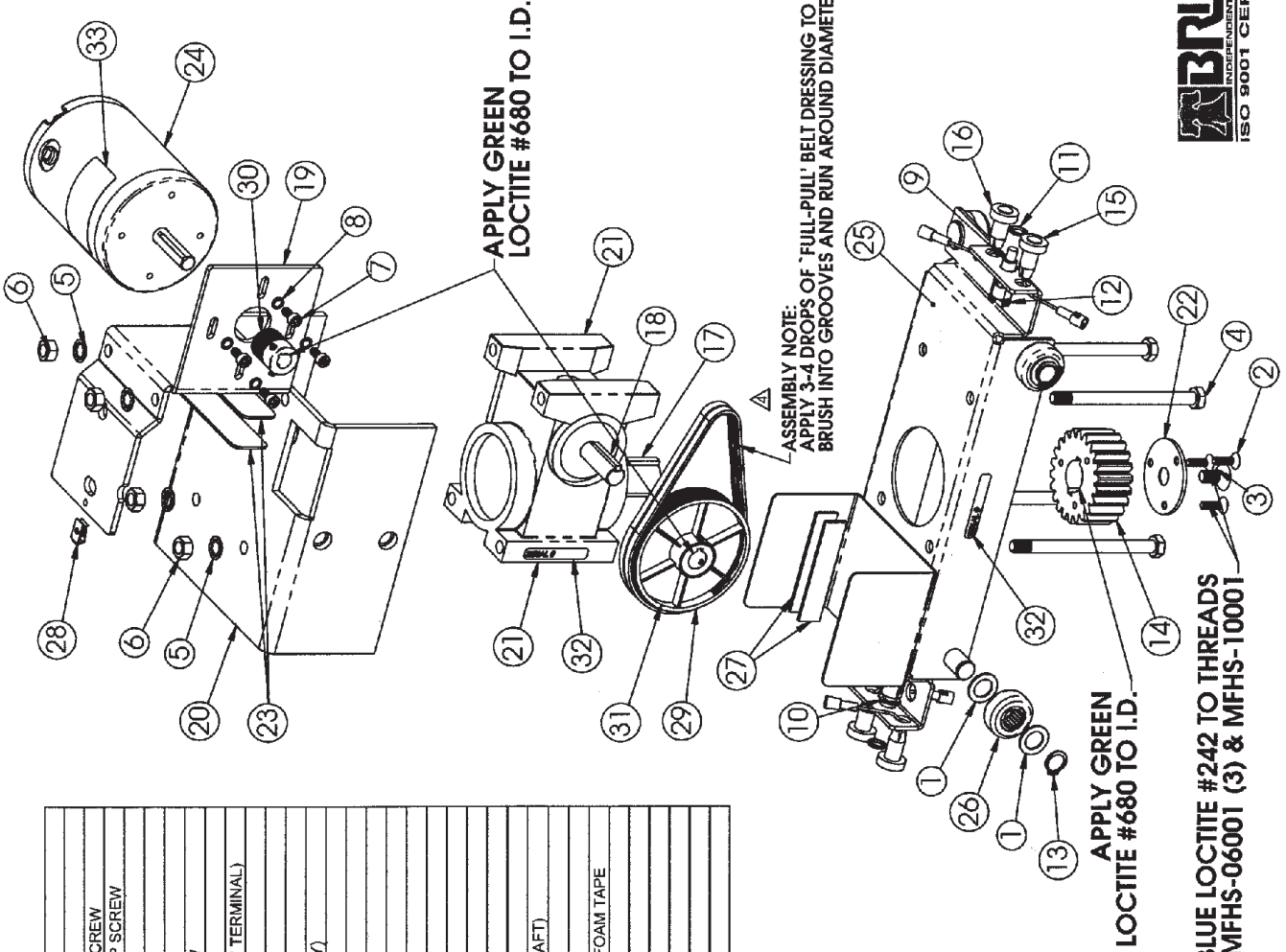

ITEM NO.	QTY.	PART NO.	DESCRIPTION
1	12	FSW-63003	5/8" I.D. X 1" O.D. X .062" THK FLAT WASHER
2	3	MFHS-06001	M6 X 1 X 20mm LG FLAT SOCKET HEAD CAP SCREW
3	4	MFHS-10001	M10 X 1.5 X 20mm LG FLAT HEAD SOCKET CAP SCREW
4	4	MHCS-10005	M10 X 1.5 X 130mm LG HEX HEAD CP SCREW
5	4	MITW-10001	M10 INTERNAL TOOTH WASHER
6	4	MNPL-10150	M10 X 1.5 HEX NUT (PLATED)
7	4	MSHS-06001	M6 X 1 X 14mm LG SOCKET HEAD CAP SCREW
8	4	MSLW-06001	M6 SAFETY LOCK WASHER
9	2	PBS-00102	SPST NC PUSHBUTTON SWITCH (.75A SCREW TERMINAL)
10	2	~	HEXAGON LOCKNUT (PBS-00102)
11	2	~	HEXAGON FACENUT (PBS-00102)
12	4	~	TERMINAL SCREW (PBS-00102)
13	6	RTR-63002	5/8" RETAINING RING (EXTERNAL/HEAVY DUTY)
14	1	SPG-08203	SPUR GEAR
15	2	SRE-00088	CHARGE CONTACT ASSEMBLY (+)
16	2	SRE-00089	CHARGE CONTACT ASSEMBLY (-)
17	2	SRE-00181	1/4" SQ KEY (1.13" LG)
18	1	SRE-00182	3/16" SQ KEY - 1 5/8" LG
19	1	SRE-00377CP	MOTOR MOUNT
20	1	SRE-00447	CARRIAGE BRACKET WELDMENT
21	1	SRE-00462	SRE GEAR BOX
22	1	SRE-00484	SPUR GEAR END PLATE
23	2	SRE-00611	MOTOR MOUNT STABILIZER
24	1	SRE-00634	24VDC PERMANENT MAGNET MOTOR (1/2" SHAFT)
25	1	SRE-00658	CARRIAGE WELDMENT
26	6	SRE-20119	3.5" LG 3/4" WIDE DOUBLE COATED ACRYLIC FOAM TAPE
27	2	TAP-75000	3.5" LG 3/4" WIDE DOUBLE COATED ACRYLIC FOAM TAPE
28	1	UNT-08001	#8 U-NUT (BLACK)
29	2	VBL-17501	17.5" J3 POLY-RIB BELT
30	1	VPY-10003	Ø1.7 GROOVE J-POLY V PULLEY
31	1	VPY-40002	7 GROOVE J-POLY V PULLEY
32	2	~	SERIAL NO. LABEL (SMALL)
33	1	~	SERIAL NO. LABEL (LARGE)



SRE-00648
REV. 4 (2537)(5/9/03)(JWV)

APPLY BLUE LOCTITE #242 TO THREADS OF MFHS-06001 (3) & MFHS-10001

APPLY GREEN LOCTITE #680 TO I.D.

APPLY GREEN LOCTITE #680 TO I.D.

ASSEMBLY NOTE:
 APPLY 3-4 DROPS OF FULL-PULL BELT DRESSING TO EACH BELT.
 BRUSH INTO GROOVES AND RUN AROUND DIAMETER OF EACH BELT.

EXPLODED VIEW AND BILL OF MATERIALS

SEAT ASSEMBLY (SRE-1550)

ITEM NO.	QTY.	PART NO.	DESCRIPTION
1	2	ARM-1-0001	1/8" X 3/8" ALUMINUM BACK-UP WASHER
2	1	BHS-0005	BEARING
3	1	BHS-0007	HEAD STATIONARY CONE
4	1	BLT-00005A	RETRACTABLE LAP BELT (BUCKLE END)
5	1	BLT-00005B	RETRACTABLE LAP BELT (RETRACTOR SIDE)
6	1	BRC-00003	1/2" FLANGE BEARING
7	1	CCL-38001	3/8" ID CABLE CLAMP (STEEL w/RUBBER CUSHION)
8	2	CPP-83003	5/8" PRY-OUT CAP PLUG - BLACK
9	2	DWS-06002	#6 X 1.25" LG DRYWALL SCREW
10	6	FSW-26001	1/4" FLAT WASHER
11	1	JNT-60132	1/2-13 NYLON INSERT JAM NUT
12	1	MEC-00123	3 CIRCUIT (FEMALE) .062 CONNECTOR HOUSING
13	1	MEC-00124	2 CIRCUIT (MALE) .062 CONNECTOR HOUSING
14	2	MEW-06001	M6 EXTERNAL TOOTH WASHER
15	4	MFS-10001	M10 X 1.5 X 20mm LG FLAT HEAD SOCKET CAP SCREW
16	2	MHCS-06001	M6 X 1.25 X 16mm LG HEX HEAD CAP SCREW
17	1	MHCS-06004	M6 X 1.25 X 40mm LG HEX HED CAP SCREW
18	1	MHCS-06005	M6 X 1.25 X 50mm LG HEX HED CAP SCREW
19	1	MHCS-06005	M8 X 1.25 X 40mm LG HEX WASHER HEAD MACHINE SCREW
20	2	MHWH-05001	M6 X 1 NYLON INSERT LOCK NUT
21	2	MNSN-06125	M6 X 1.25 NYLON INSERT LOCK NUT
22	3	MPLM-06001	M6 X 1 X 20mm LG PHILLIPS FILLISTER HEAD MACHINE SCREW
23	6	MPLM-06003	M6 X 1 X 25mm LG PHILLIPS FILLISTER HEAD MACHINE SCREW
24	2	MPLM-06007	M6 X 1 X 40mm LG PHILLIPS FILLISTER HEAD MACHINE SCREW
25	4	MPLM-06007	M6 X 1 X 40mm LG PHILLIPS FILLISTER HEAD MACHINE SCREW
26	6	SNW-39401	NYLON WASHER (3/84" ID X .785" OD X .080" THK)
27	1	SPR-00028	SEAT HOLD-UP COMPRESSION SPRING
28	2	SPR-00030	SEAT LATCH SWITCH PLATE SPRING
29	1	SRE-00109UL	SERIAL NO. LABEL (ULL)
30	1	SRE-00193UL	SEAT FRAME
31	1	SRE-00193CP	SEAT ADJUSTMENT TUBE WELDMENT w/BEARING CUP
32	1	SRE-00374	SEAT BASE PLATE
33	1	SRE-00401L	LEFT ARMREST
34	1	SRE-00401R	RIGHT ARMREST
35	2	SRE-00422	SEAT SHIM (REAR)
36	2	SRE-00433	MOLDED ARM PAD
37	1	SRE-00450	SWIVEL SHIRT WELDMENT
38	1	SRE-00471	OUTER SPRING HOUSING
39	1	SRE-00472	INNER SPRING HOUSING
40	1	SRE-00475	INNER SPRING HOUSING INT.G. SPACER
41	1	SRE-00476	OUTER SPRING HOUSING INT.G. SPACER
42	1	SRE-00481	CATCH PLATE WELDMENT
43	1	SRE-00482	SEAT CUSHION BASE COVER
44	1	SRE-00483	PACKING ASSEMBLY
45	1	SRE-00539	SEAT BACK ASSEMBLY
46	1	SRE-00547	SEAT INTERCONNECT HARNESS
47	1	SRE-00547	SEAT STOP
48	4	SRE-00552	ARM GUIDE
49	2	SRE-00553	SEAT SHIM (FRONT)
50	2	SRE-00553	SEAT SHIM (FRONT)
51	2	SRE-00553	LATCH SHIM
52	1	SRE-00560(TOP)	3-WAY TENSION LATCH (TOP)
53	1	SRE-00560(BOTTOM)	3-WAY TENSION LATCH (BOTTOM)
54	2	SRE-00560	TENSION LATCH SCREW (SRE-00560)
55	1	SRE-00584	SWIVEL SWITCH COVER
56	1	SRE-00657	ARMREST HARNESS HOLDER
57	1	SRE-00660L	LEFT ARM LOCK ASSEMBLY
58	1	SRE-00660R	RIGHT ARM LOCK ASSEMBLY
59	1	SRE-00666	SWIVEL SWITCH ASSEMBLY
60	1	TLR-10001	1" OD TOLERANCE RING
61	4	TTH-25001	1/4-20 X .75" LG TORX TRUSS HEAD MACHINE SCREW
62	4	Y-001-114	BOLT COVER
63	1	-	DATE LABEL
64	1	-	SERIAL NO. LABEL (SMALL)

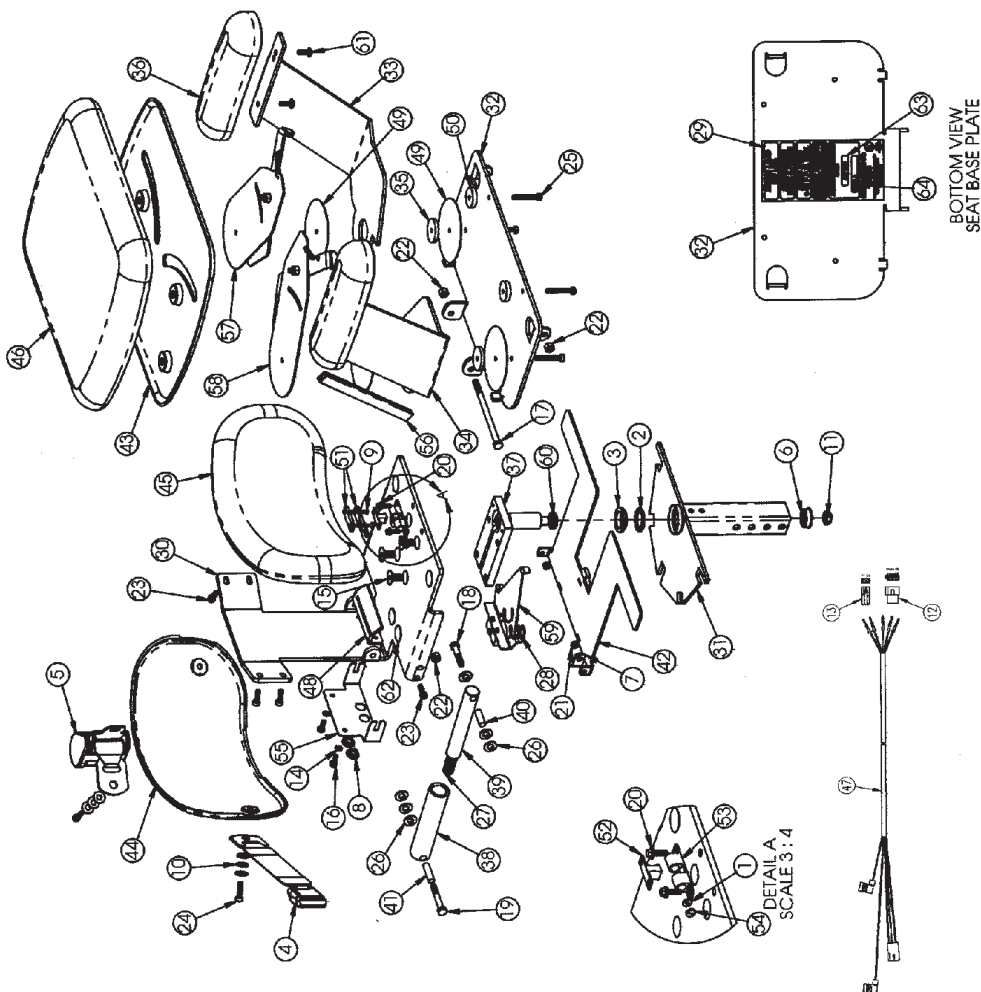

SRE-00528
REV. 13 (2689)(12/5/03)(JWV)

EXPLODED VIEW AND BILL OF MATERIALS

FOOTREST ASSEMBLY (1550)

ITEM NO.	QTY.	PART NO.	DESCRIPTION
1	1	CPP-38003	3/8" x 1/8" PANEL THK. DOME CAP PLUG
2	2	GSK-43800	7.5" LG BLACK GASKET (W/ADHESIVE BACKING)
3	2	MCLN-10150	M10 X 1.5 HEX CENTER LOCK NUT
4	2	MNSN-05081	M5 X .8 NYLON INSERT LOCK NUT
5	1	MPLM-05001	M5 X .8 X 25MM LG PHILLIPS FILLISTER HEAD MACHINE SCREW
6	3	MPLM-06008	M6 X 1 X 12mm LG PHILLIPS FILLISTER HEAD MACHINE SCREW
7	2	MSSS-08001	M8 X 1.25 X 10MM LG SET SCREW - BRIGHT ZINC
8	3	NSW-25401	254" DIA. NYLON SHOULDER WASHER
9	2	PBS-00102	SPST NC PUSHBUTTON SWITCH (.75A SCREW TERMINAL)
10	2	-	HEXAGON LOCKNUT (PBS-00102)
11	2	-	HEXAGON FACENUT (PBS-00102)
12	4	-	TERMINAL SCREW (PBS-00102)
13	2	SAE-38001	3/8" SAE WASHER
14	4	SNW-39401	NYLON WASHER (.394" ID X .785" OD X .080" THK)
15	1	SRE-00099	FOOTREST LIMIT HARNESS
16	1	SRE-00409	FOOTREST SWITCH ACTUATOR
17	1	SRE-00410	11" FOOTREST SAFETY PAN
18	2	SRE-00419	FOOTREST PIVOT BOLT
19	1	SRE-00428	FOOTREST
20	2	SRE-00503	FOOTREST SAFETY SWITCH PIN
21	1	SRE-00514	FOOTREST COVER (11")
22	1	SRE-00632	FOOTREST HANGER WELDMENT (SHORT)

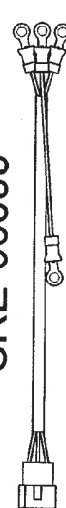
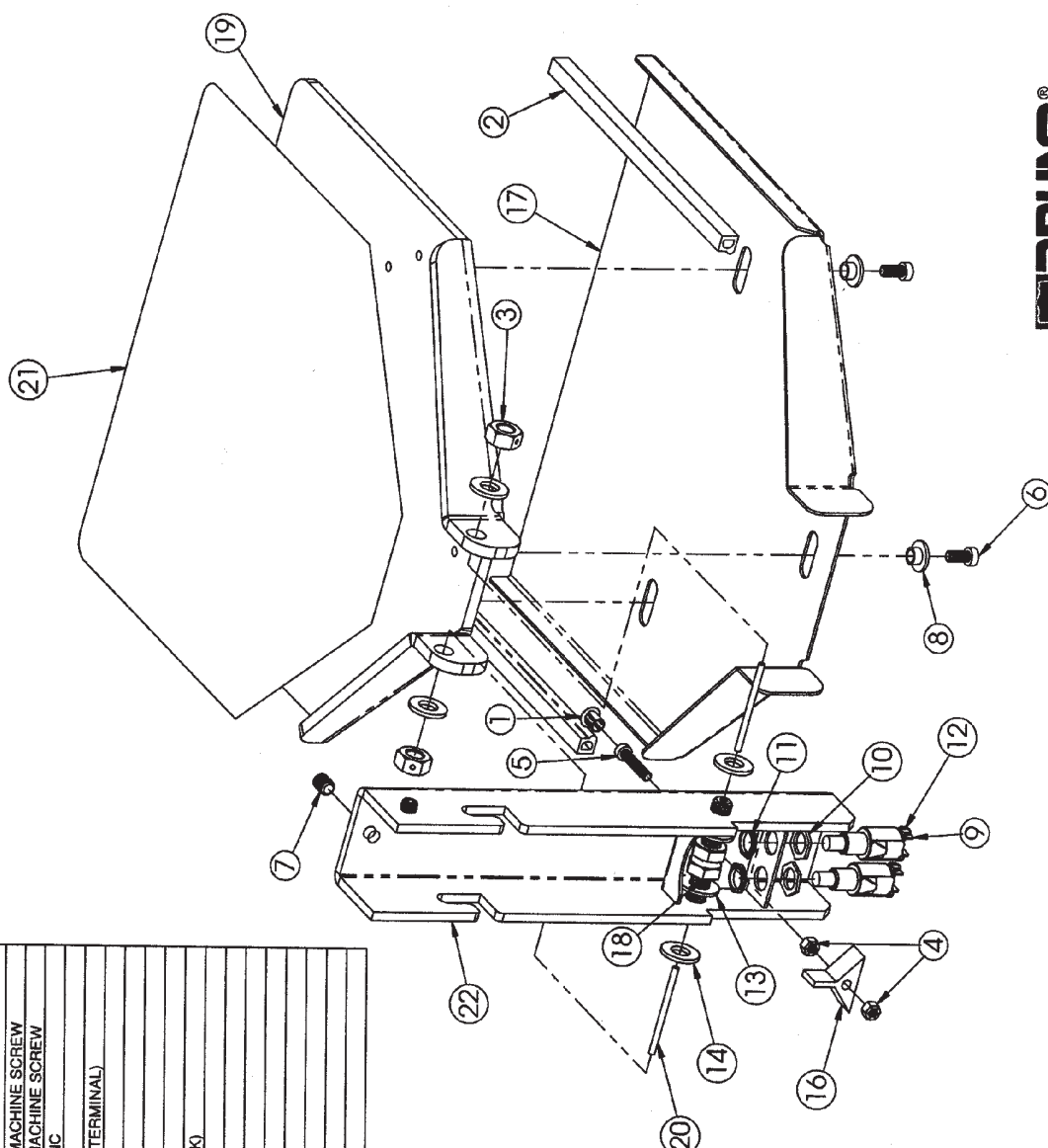

SRE-00099



SRE-00529
REV. 5 (1844)(3-8-00)(RJH)

EXTENDED FOOTREST ASSEMBLY

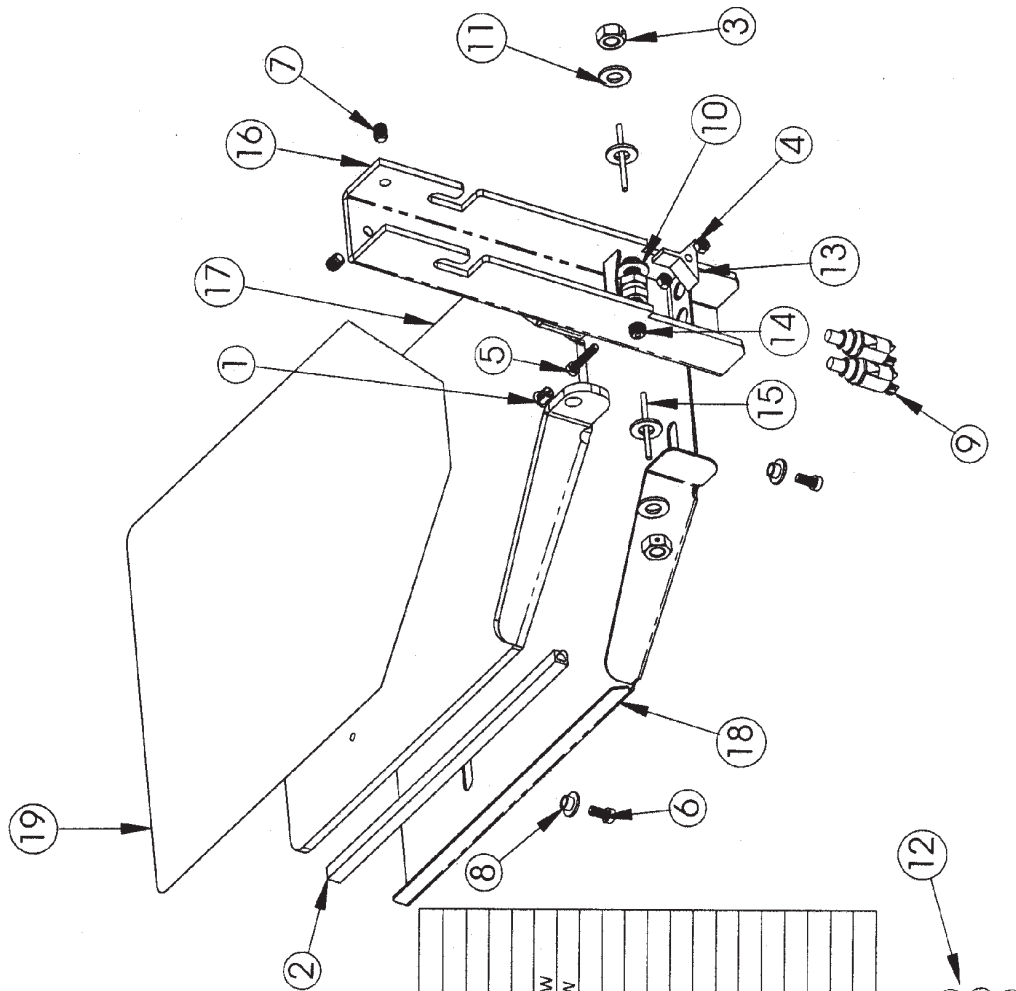

ITEM NO.	QTY.	PART NO.	DESCRIPTION:
1	1	CPP-38003	3/8" x 1/8" PANEL THK. DOME CAP PLUG
2	2	GSK-43800	10.5" LG BLACK GASKET (w/ADHESIVE BACKING)
3	2	MCLN-10150	M10 X 1.5 HEX CENTER LOCK NUT
4	2	MNSN-05081	M5 X .8 NYLON INSERT LOCK NUT
5	1	MPLM-05001	M5 X .8 X 25MM LG PHILLIPS FILLISTER HEAD MACHINE SCREW
6	3	MPLM-06008	M6 X 1 X 12mm LG PHILLIPS FILLISTER HEAD MACHINE SCREW
7	2	MSSS-08001	M8 X 1.25 X 10MM LG SET SCREW - BRIGHT ZINC
8	3	NSW-25401	.254" DIA. NYLON SHOULDER WASHER
9	2	PBS-00102	SPST NC PUSHBUTTON SWITCH (.75A SCREW TERMINALS)
10	2	SAE-38001	3/8" SAE WASHER
11	4	SNW-39401	NYLON WASHER (.394" ID X .785" OD X .080" THK)
12	1	SRE-00099	FOOTREST LIMIT HARNESS
13	1	SRE-00409	FOOTREST SWITCH ACTUATOR
14	2	SRE-00419	FOOTREST PIVOT BOLT
15	2	SRE-00503	FOOTREST SAFETY SWITCH PIN
16	1	SRE-00632	FOOTREST HANGER WELDMENT (SHORT)
17	1	SRE-00649	EXTENDED FOOTREST
18	1	SRE-00650	EXTENDED FOOTREST SAFETY PAN
19	1	SRE-00652	EXTENDED FOOTREST COVER

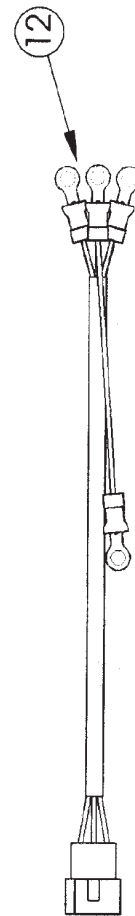

SRE-00651

REV. 0 (ISSUED 5-31-02)

EXPLODED VIEW AND BILL OF MATERIALS

'ELECTRA-RIDE II' COMMERCIAL PACKAGE

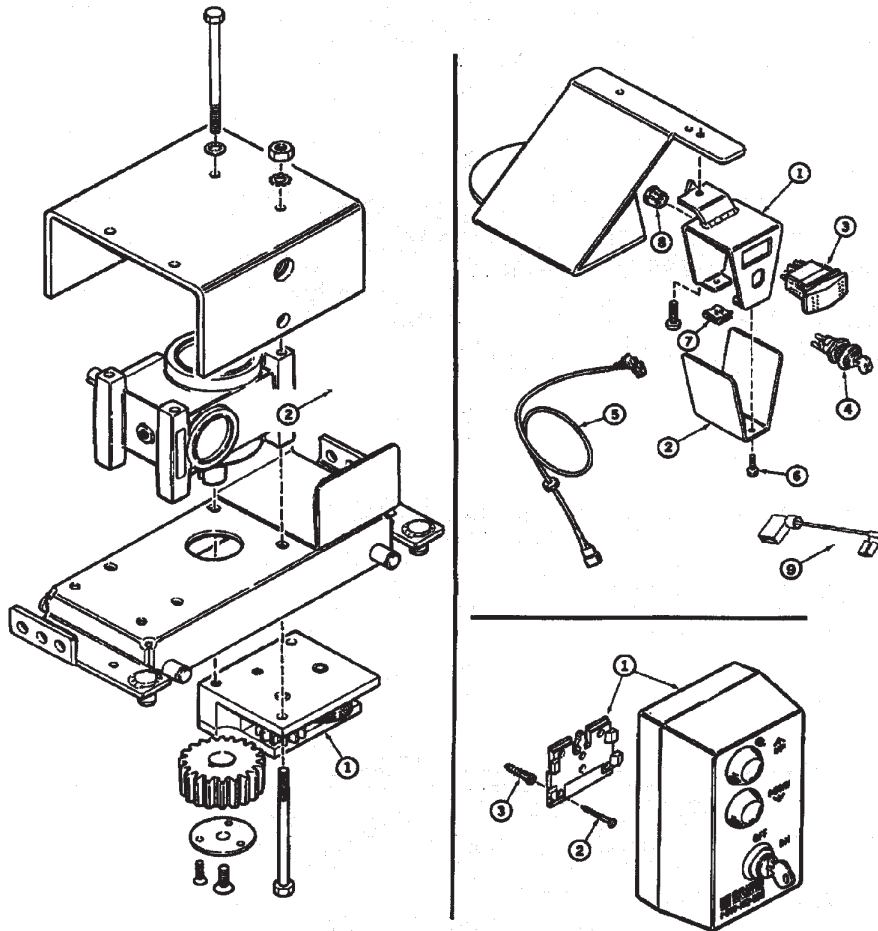

OVERSPEED ASSEMBLY TO CARRIAGE

ITEM	QTY.	PART NUMBER	DESCRIPTION
1	1	SRE-00502	OVERSPEED ASSEMBLY

SRE-00580 REV. 3 KEYLOCK SWITCH HOUSING ASSEMBLY

ITEM	QTY.	PART NUMBER	DESCRIPTION
1	1	SRE-00604	OUTER SWITCH HOUSING WELDMENT
2	1	SRE-00602	INNER SWITCH HOUSING
3	1	RSW-00104	SPDT MOMENTARY ROCKER SWITCH (OVERSIZED)
Δ 4	1	KYS-00108	KEYSWITCH (2 POS., KEYCODE #2252, .25" SPADE TERM., KEYPULL POS. 1 ONLY)
Δ 5	1	SRE-00459	KEYLOCK CONTROL HARNESS
6	2	MHWH-05001	M5 X .8 X 16mm LG HEX WASHER HEAD MACHINE SCREW
7	2	MUNT-05001	M5 X .8 METRIC 'U'-NUT
8	1	BUS-63002	5/8" SNAP BUSHING
Δ 9	1	CRE-00281	ARMREST KEYSWITCH JUMPER

KEYED TRANSMITTER ASSEMBLY

ITEM	QTY.	PART NUMBER	DESCRIPTION
1	2	SRE-00055A	KEYED TRANSMITTER ASSEMBLY w/WALL MOUNTING BRACKET
2	4	PFW-04001 (SRE-K-055A)	#4 X 1" LG PHILLIPS FLAT HEAD WOOD SCREW
3	4	ANC-00002 (SRE-K-055A)	#4/#6/#8 X .88" LG RIBBED PLASTIC WALL ANCHOR
~	1	SRE-K-055A	KEYED CALL/SEND HARDWARE KIT

() INDICATES SUB-ASSEMBLY NO.
 ©2001 BRUNO INDEPENDENT LIVING AIDS, INC.

SRE-1550C
 (ISSUED 4-23-01)

OVERSPEED ASSEMBLY

EXPLODED VIEW AND BILL OF MATERIALS

ITEM	REQD	PART NUMBER	DESCRIPTION
1	1	SRE-00399	OVERSPEED HOUSING
2	1	SRE-00398	OVERSPEED HOUSING COVER
3	4	BRG-38001	NEEDLE BEARING
4	1	CHN-25017	#25 CHAIN - 17 LINK LENGTH
	1	CHL-25001	#25 CHAIN LINK
*5	1	SRE-00395	OVERSPEED SPROCKET (#25 22 TOOTH w/.75" ID BORE)
6	1	SRE-00388	DRIVE GEAR
7	1	SRE-00400	CAM SUPPORT NUT
8	1	SRE-00556	OVERSPEED SAFETY SWITCH SUB-ASSEMBLY
9	1	SRE-00397L	OVERSPEED WEIGHT (LEFT)
10	1	SRE-00397R	OVERSPEED WEIGHT (RIGHT)
11	1	SPR-00022	EXTENSION SPRING (OVERSPEED WEIGHT)
12	1	SRE-00389	GOVERNOR ROTOR SHAFT
13	1	SRE-00390	OVERSPEED CAM LOCK
14	1	GRR-31002	RUBBER GROMMET (.313" ID X .81" OD X .56" GROOVE DIA.)
15	3	SNW-44301	NYLON WASHER (.443" ID X 3/4" OD X .032" THK)

HARDWARE

1	3	MFHS-10001	M10 X 1.5 X 20mm LG FLAT SOCKET HEAD CAP SCREW
2	2	MPLM-02501	M2.5 X 0.45 X 16mm LG PHILLIPS PAN HEAD MACHINE SCREW
3	2	SSLS-19001	3/16 DIA. X .19" LG. SOCKET HEAD SHOULDER SCREW (#8-32 THREAD)
4	1	RPS-13003	1/8" DIA. X .5" LG ROLL PIN
5	1	RPS-13001	1/8" DIA. X 1" LG ROLL PIN

SPECIFICATIONS:

-ACTIVATION SPEED: 55-60 FT/SEC

-STOPPING DISTANCE: APPROX. 4" (10cm) w/350 LBS (159kg) LOAD

INSTRUCTIONS FOR RESETTNG OVERSPEED:

-IF THE OVERSPEED SHOULD BE TRIPPED WHILE SERVICING OR INSTALLING, THE CAM MAY BE RESET BY ROTATING THE CAM BACK TO ITS DETENT POSITION BY BYPASSING THE OVERSPEED SWITCH & RUNNING THE DRIVE UNIT UP, THE CAM CAN BE ROTATED IN BY HAND.

-SHOULD A FAILURE OCCUR WHICH WOULD ACTIVATE THE OVERSPEED, THE COMPLETE DRIVE UNIT WILL HAVE TO BE REMOVED FROM THE RAIL & RETURNED TO THE DEALER OF THE MANUFACTURE TO DETERMINE THE REASON FOR THE FAILURE. REPAIRS WOULD THEN HAVE TO BE COMPLETED BEFORE THE UNIT COULD BE USED AGAIN.

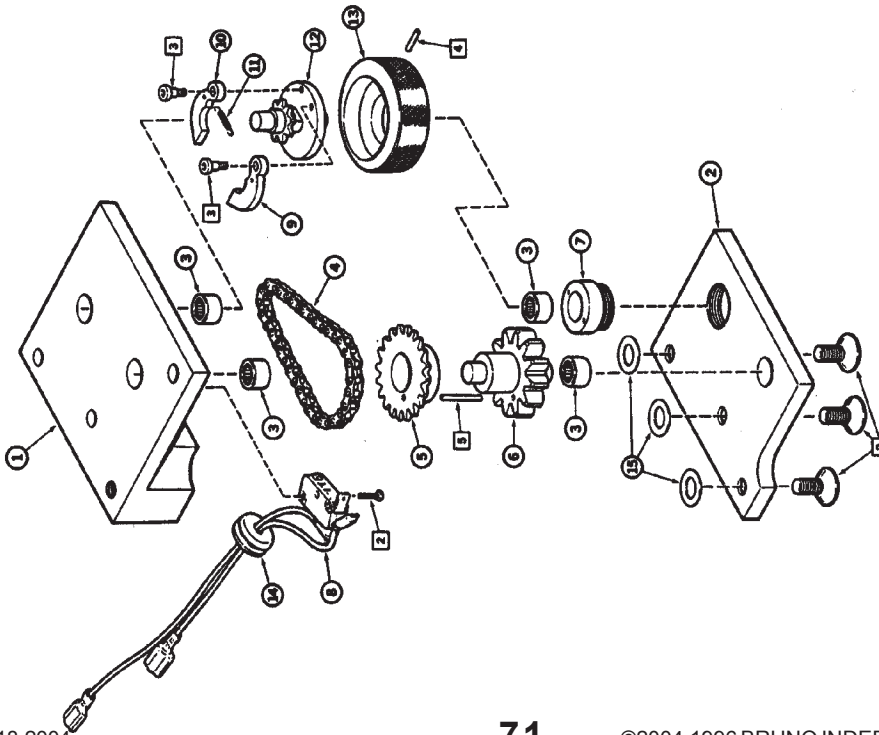

SRE-00502

REV. 3 (ISSUED 6-22-01)

*INDICATES CHANGED ITEM(S)

EXPLODED VIEW AND BILL OF MATERIALS

STD. IR TRANSMITTER/BACKET/HDWR

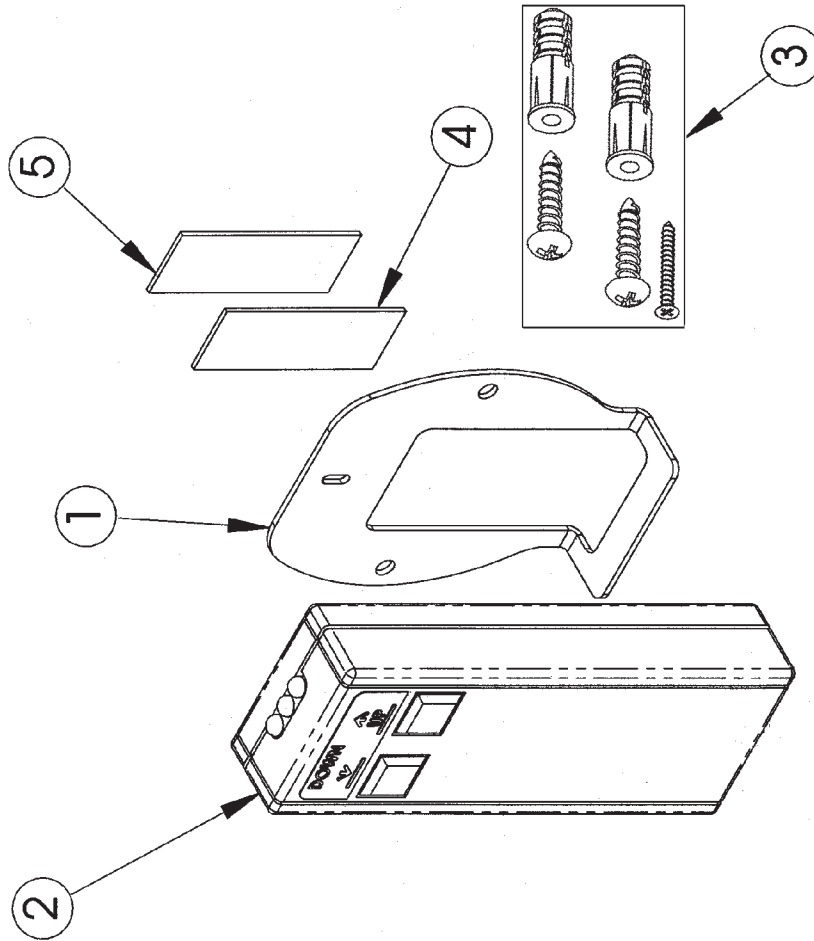

ITEM NO.	QTY.	PART NO.	DESCRIPTION
1	1	SRE-27052	CALL SEND UL MOUNTING BRACKET
2	1	SRE-27092	TRANSMITTER ASSEMBLY
3	1	SRE-K-2701	TRANSMITTER HARDWARE KIT
4	1	VHK-75000	2" LG 3/4" WIDE VELCRO HOOK w/ADHESIVE BACKING
5	1	VLP-75000	2" LG 3/4" WIDE VELCRO LOOP w/ADHESIVE BACKING



SRE-00664
REV. 0 (2709)(1/12/04)(JWW)

COMPLETE 16' RAIL KIT

EXPLODED VIEW AND BILL OF MATERIALS

ITEM NO.	QTY.	PART NO.	DESCRIPTION
1	1	LUB-00102	LUBRI-PLATE 1.75 OZ. TUBE
2	8	MHCS-12001	M12 X 1.75 X 220MM HEX HEAD CAP SCREW
3	16	SRE-00104CP	TALL CLAMP FOOT
4	16	SRE-00108CP	CLAMP
5	8	SRE-00172	SPACER TUBE
6	1	SRE-00637	UL BUMPER SUB-ASSEMBLY (#1)
7	1	SRE-00638	UL BUMPER SUB-ASSEMBLY (#2)
8	1	SRE-K-1501	16' RAIL ELECTRICAL PARTS KIT
9	1	SRE-K-1507	SHEET METAL SCREWS KIT (32)
10	1	SRE-K-1517	CLAMP SET NUTS & WASHERS
11	1	SRE-K-1546	16' RAIL/JOINT PLATE KIT
12	1	SRE-K-1563	BUMPER ASSEMBLY PARTS KIT
13	1	SRE-K-1561	FINAL LIMIT RAMP ASSEMBLY KIT
14	9	WRT-14402	11" LG. WIRE TIE (.144" WIDTH)

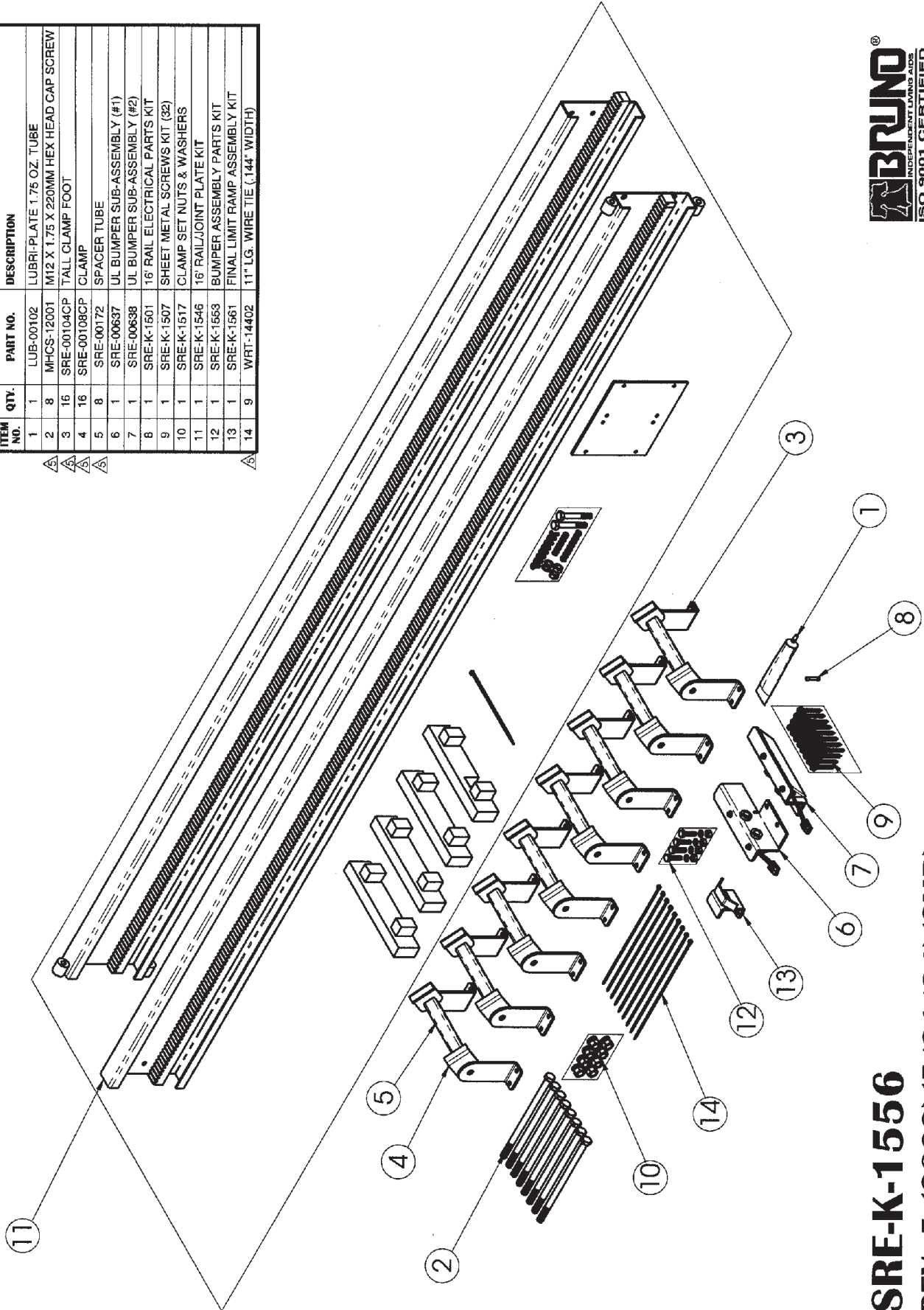

SRE-K-1556
REV. 5 (2808)(5/21/04)(SMR)

EXPLODED VIEW AND BILL OF MATERIALS

COMPLETE 20' RAIL KIT

ITEM NO.	QTY.	PART NO.	DESCRIPTION
1	2	LUB-00102	LUBRI-PLATE 1.75 OZ. TUBE
2	10	MHCS-12001	M12 X 1.75 X 220MM HEX HEAD CAP SCREW
3	2	MITW-12001	M12 INTERNAL TOOTH WASHER
4	2	MNPL-12175	M12 X 1.75 HEX NUT
5	8	MSSM-63001	M6.3 X 50mm LG SLOTTED HEX HEAD SHEET METAL SCREW
6	20	SRE-00104CP	TALL CLAMP FOOT
7	20	SRE-00108CP	CLAMP
8	10	SRE-00172	SPACER TUBE
9	1	SRE-00637	UL BUMPER SUB-ASSEMBLY (#1)
10	1	SRE-00638	UL BUMPER SUB-ASSEMBLY (#2)
11	1	SRE-K-1507	SHEET METAL SCREWS KIT (32)
12	1	SRE-K-1517	CLAMP SET NUTS & WASHERS
13	1	SRE-K-1521	20' RAIL ELECTRICAL PARTS KIT
14	1	SRE-K-1545	20' RAIL JOINT PLATE KIT
15	1	SRE-K-1563	BUMPER ASSEMBLY PARTS KIT
16	1	SRE-K-1561	FINAL LIMIT RAMP ASSEMBLY KIT
17	11	WRT-14402	11' LG. WIRE TIE (.144" WIDTH)

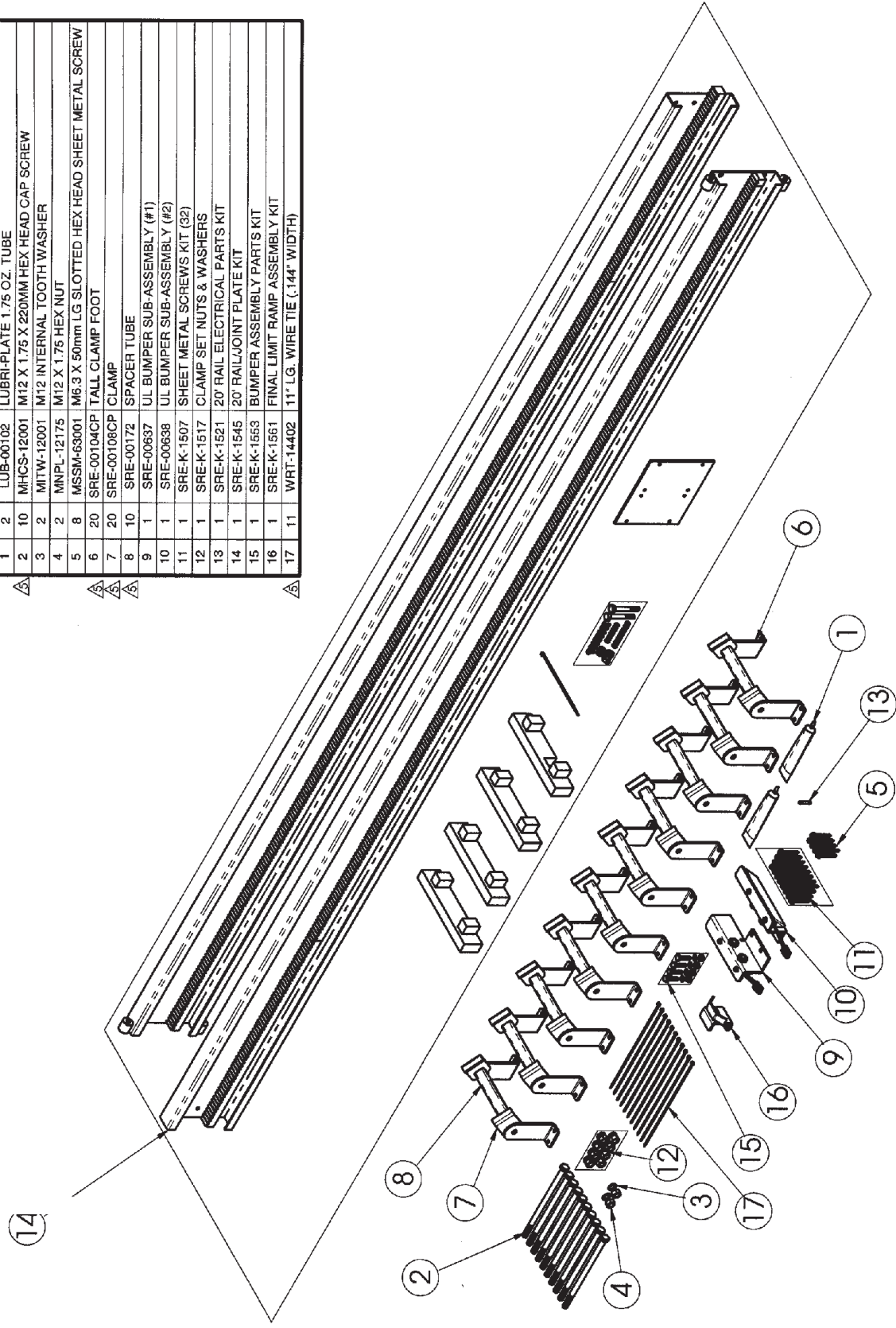

SRE-K-1555
REV. 5 (2808)(5/21/04)(SMR)

EXPLODED VIEW AND BILL OF MATERIALS

COMPLETE 24' RAIL KIT

ITEM NO.	QTY.	PART NO.	DESCRIPTION
1	1	LUB-00102	LUBRI-PLATE 1.75 OZ. TUBE
2	13	MHCS-12001	M12 X 1.75 X 220MM HEX HEAD CAP SCREW
3	5	MITW-12001	M12 INTERNAL TOOTH WASHER
4	5	MNPL-12175	M12 X 1.75 HEX NUT
5	20	MSSM-63001	M6.3 X 50mm LG SLOTTED HEX HEAD SHEET METAL SCREW
6	26	SRE-00104CP	TALL CLAMP FOOT
7	26	SRE-00106CP	CLAMP
8	13	SRE-00172	SPACER TUBE
9	1	SRE-00637	UL BUMPER SUB-ASSEMBLY (#1)
10	1	SRE-00638	UL BUMPER SUB-ASSEMBLY (#2)
11	1	SRE-K-1501	16' RAIL ELECTRICAL PARTS KIT
12	1	SRE-K-1507	SHEET METAL SCREWS KIT (32)
13	1	SRE-K-1517	CLAMP SET NUTS & WASHERS
14	1	SRE-K-1542	24' RAIL/JOINT PLATE KIT
15	1	SRE-K-1563	BUMPER ASSEMBLY PARTS KIT
16	1	SRE-K-1581	FINAL LIMIT RAMP ASSEMBLY KIT
17	13	WRT-14402	11" LG. WIRE TIE (1.44" WIDTH)

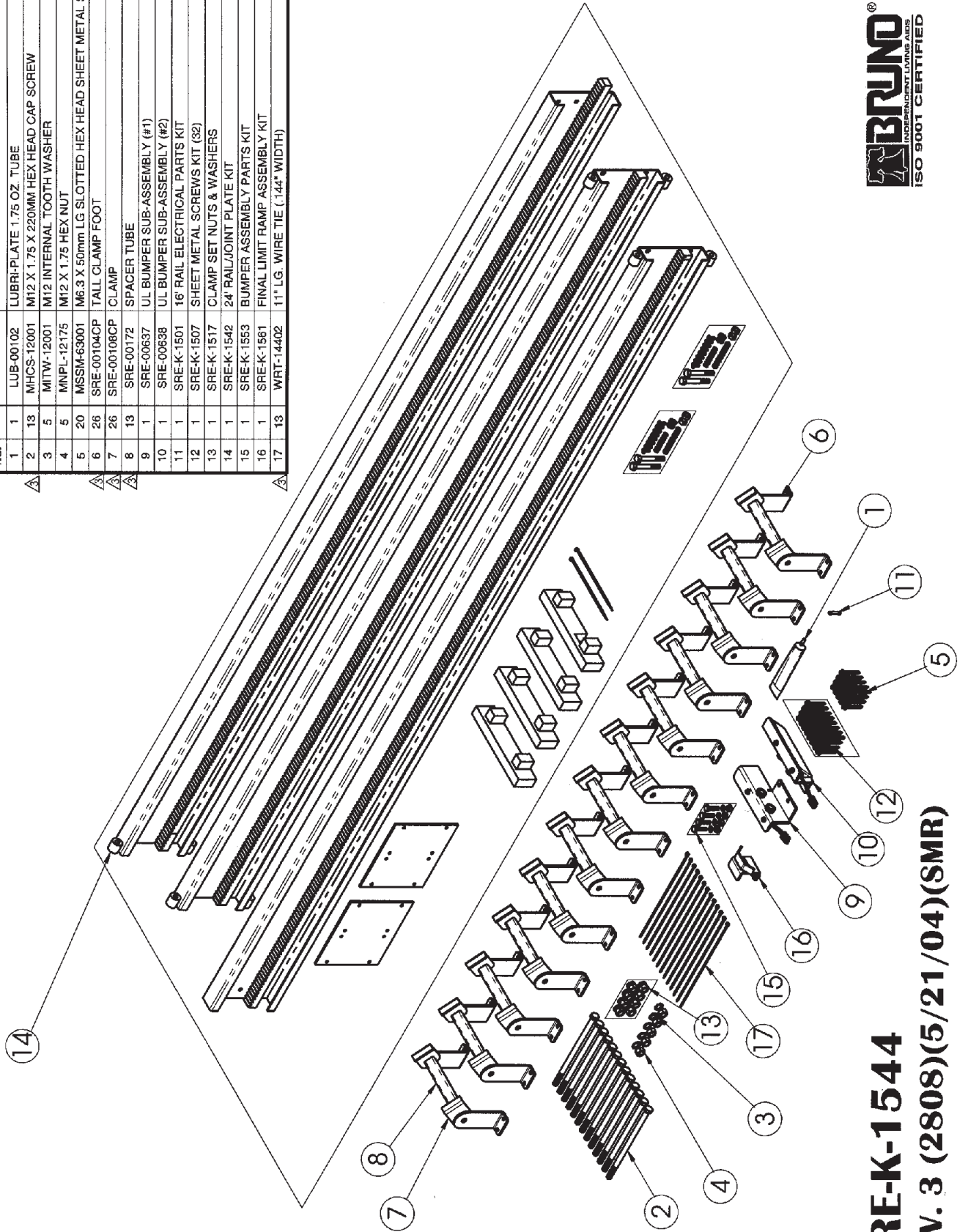

SRE-K-1544
REV. 3 (2808)(5/21/04)(SMR)

**FIVE YEAR MAJOR COMPONENTS WARRANTY
TWO YEAR LIMITED WARRANTY
for
Bruno Stairlifts**

Bruno Independent Living Aids, Inc. ("Bruno"), warrants to the original purchaser of a Bruno Stairlift that the Bruno Stairlift is free from defects in material and workmanship for a period of two years from date of purchase. In addition, Bruno warrants that the motor, gear box and rail (the "Major Components") will be free from defects in materials and workmanship for a period of five years from the date of purchase.

The exclusive remedy for a defect in a Bruno Stairlift shall be the repair or replacement, at the option of Bruno, of the defective part or component. After the first 30 days of this warranty, only parts and components are covered. This warranty does not cover labor and other services after the initial 30 days. If repair or replacement of a Bruno Stairlift is not commercially practical or cannot be timely made, Bruno may elect to refund the purchase price of the Bruno Stairlift instead of repairing or replacing the Bruno Stairlift.

IN NO EVENT SHALL BRUNO BE RESPONSIBLE FOR INDIRECT, INCIDENTAL OR CONSEQUENTIAL DAMAGES, WHETHER SUCH DAMAGES ARISE FROM CLAIMS BASED ON CONTRACT, WARRANTY, TORT (INCLUDING NEGLIGENCE), STRICT LIABILITY OR PRODUCT LIABILITY. Some states do not allow the exclusion or limitation of incidental or consequential damages, so the above limitation or exclusion may not apply to you.

ALL IMPLIED WARRANTIES, INCLUDING ANY WARRANTY OF MERCHANTABILITY OR FITNESS FOR A PARTICULAR PURPOSE, ARE LIMITED IN THEIR DURATION TO THE LENGTH OF THE WARRANTY STATED ABOVE FOR THE AFFECTED COMPONENT. Some states do not allow limitations on how long an implied warranty lasts so the above limitation may not apply to you.

To obtain warranty service, you must follow these procedures:

1. Obtain return authorization by calling your local Bruno dealer or Bruno at 1-800-882-8768;
2. Return the Bruno Stairlift, freight prepaid, to the address provided by your Bruno dealer or Bruno with proof of purchase indicating the date purchased.

Bruno will pay for shipping back to the purchaser within the continental United States and Canada if a defect in material or workmanship is discovered. Return freight and repair charges will be the responsibility of the purchaser if the problem is not covered by warranty.

This warranty does not cover damage or failure caused by misuse, abuse, accidents, physical damage, modifications not made by Bruno, damage in shipment, or repairs undertaken by anyone other than Bruno factory employees or authorized distributors. The "original purchaser" of a Bruno Stairlift that is leased or rented shall be the person or entity acting as the lessee or rental provider.

This warranty gives you specific legal rights, and you may also have other rights which vary from state to state. Bruno specifically does not authorize any person to extend the time or scope of this warranty.

For further information regarding this limited warranty, please contact Bruno by calling 1-800-882-8768 or writing to Bruno at the following address:

Bruno Independent Living Aids, Inc.
Attention: Service Department
1780 Executive Drive, Post Office Box 84
Oconomowoc, WI 53066 USA